

FILENAME: y:\inter-departmental\development engineering projects\public works standards\2.0 pws revision copy\details\cad - all\500_water\501a.dwg, Plotted 4/20/2026 10:51 AM, By: Anthony Dollowitch, ANSI FULL BLEED A (8.50 X 11.00 INCHES)

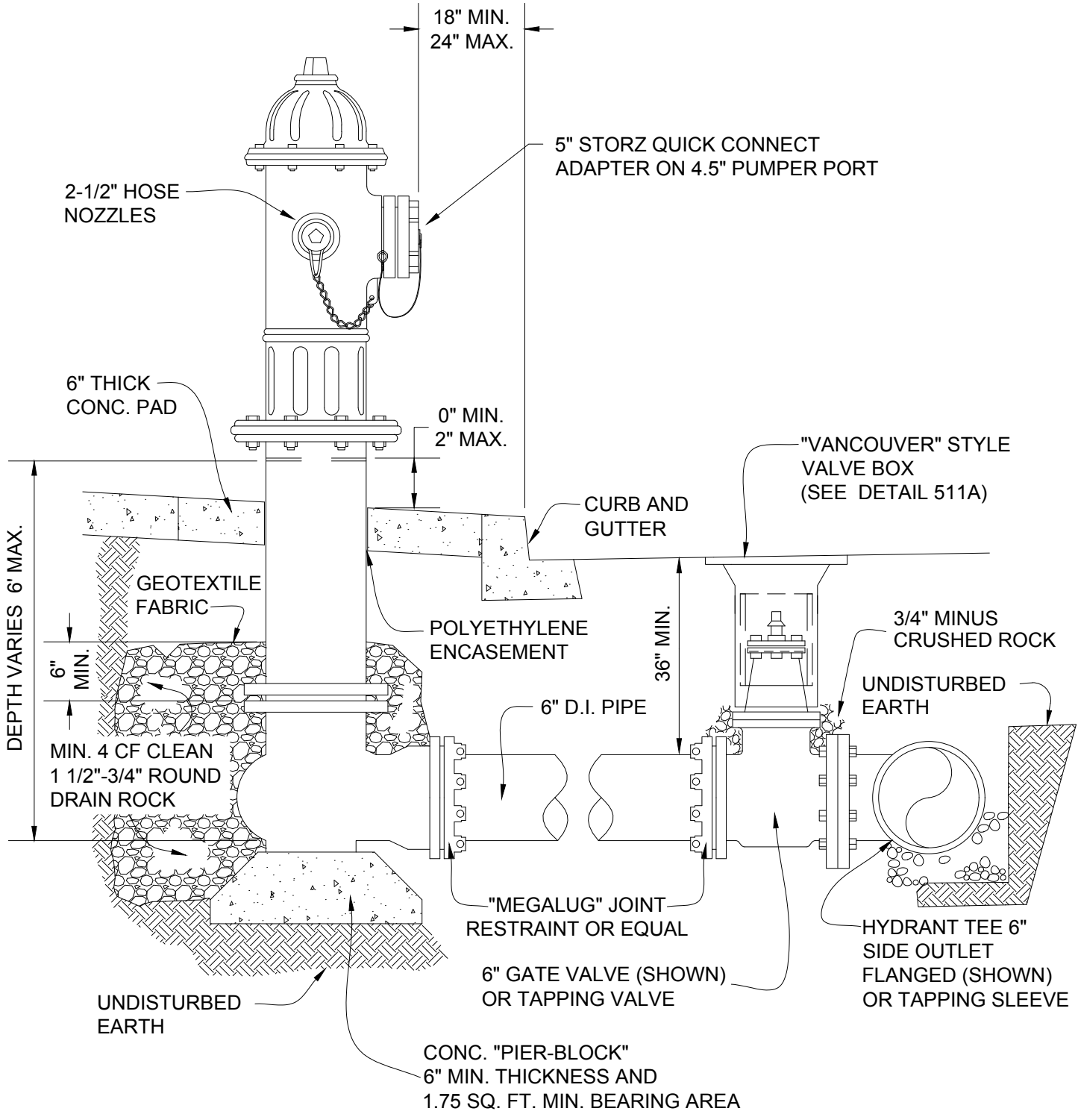

NOTE:

1. WHERE CURB TIGHT SIDEWALK (NO PLANTER STRIP) AND CURB EXIST. HYDRANT PUMPER PORT SHALL BE PLACED AT BACK OF SIDEWALK, OR AS DIRECTED BY ENGINEER .
2. FOR MORE DETAIL SEE SPECIFICATIONS IN THE CITY OF GRESHAM PWS SECTION 502.
3. FIRE HYDRANT SHALL BE MUELLER SUPER CENTURION 250, MDL A-423.

CITY OF GRESHAM

FIRE HYDRANT ASSEMBLY

PWS VERSION: JULY 2026

DRAWN	RWL
REV. DATE	JAN 2024
APPR.	
DETAIL NO.	501A

 = FIRE HYDRANT

 = BLUE PAVEMENT MARKER

FIGURE 1
TWO LANE STREETS

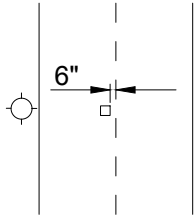

FIGURE 2
MULTI-LANE STREETS

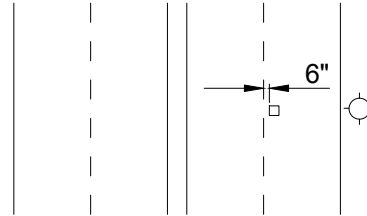

FIGURE 3
AN INTERSECTION

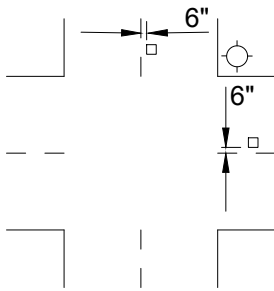

FIGURE 4
FOUR LANE STREETS WITH
TURN LANE AT INTERSECTION

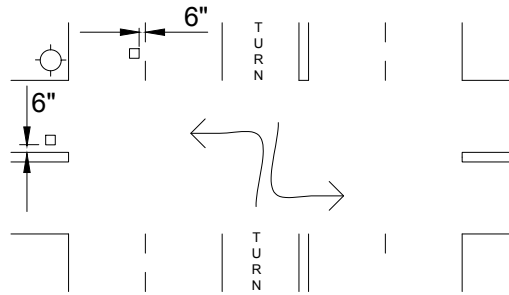

FIGURE 5
MULTI-LANE STREETS
WITH TURN LANE

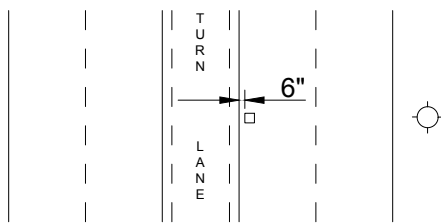
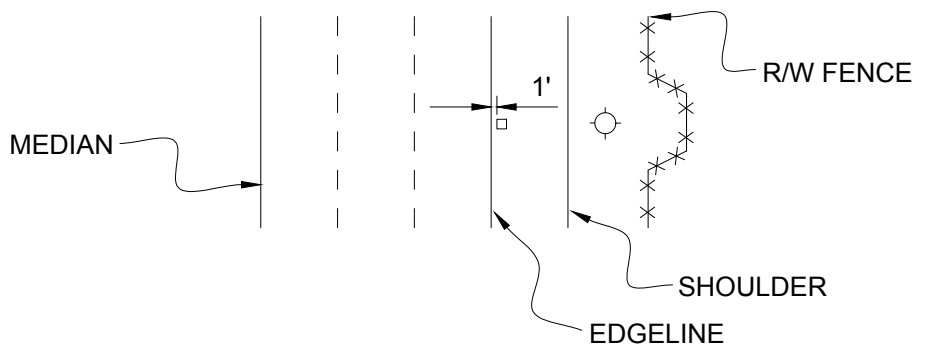

FIGURE 6
FREEWAYS AND
EXPRESSWAYS



NOTES:

1. PAVEMENT MARKER TO BE 3M 209-B TWO WAY BLUE RAISED PAVEMENT MARKER OR APPROVED EQUAL

CITY OF
GRESHAM

TYPICAL HYDRANT MARKER LOCATION

PWS VERSION: JULY 2026

DRAWN JIA

REV. DATE JAN 2019

APPR.

DETAIL NO. 501B

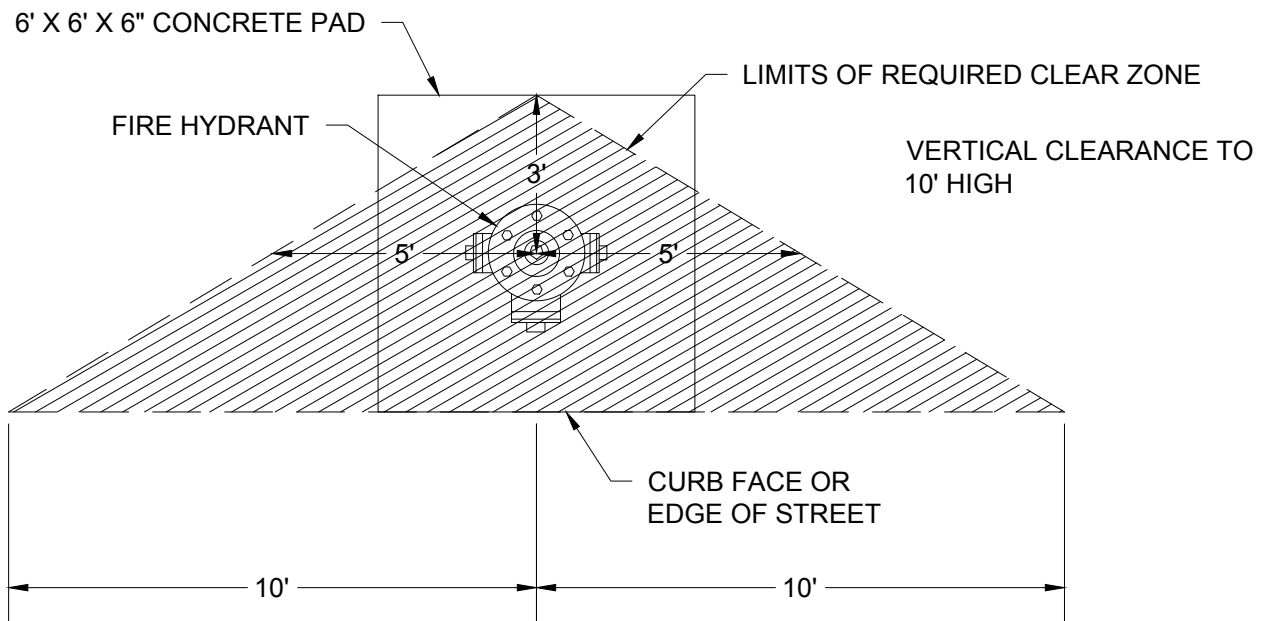

NOTES:

1. THE CLEAR ZONE PROHIBITS THE FOLLOWING:
 - VEHICLE PARKING
 - FENCES
 - TREES
 - LARGE BUSHES
 - RETAINING WALLS
 - ANYTHING ELSE THAT MAY INTERFERE WITH OPERATION OF THE FIRE HYDRANT.

2. THE CLEAR ZONE ALLOWS THE FOLLOWING:
 - LAWN GRASS
 - MULCH
 - BARK DUST
 - GROUND COVER
 - LOW PLANTINGS BELOW 6"

3. PROPERTY OWNERS SHOULD BE AWARE THE GROUND COVER COULD BE DAMAGED WHEN HYDRANT IS USED OR MAINTAINED.

FILENAME: y:\inter-departmental\development\engineering projects\public works standards\2.0 pws revision copy\details\cad - all\500_water\501c.dwg, Plotted 4/20/2026 10:51 AM, By: Anthony Dollowitch, ANSI FULL BLEED A (8.50 X 11.00 INCHES)

	<h2 style="margin: 0;">FIRE HYDRANT CLEAR ZONE</h2>	DRAWN RWL
		REV. DATE JAN 2019
		APPR.
		DETAIL NO. 501C
PWS VERSION: JULY 2026		

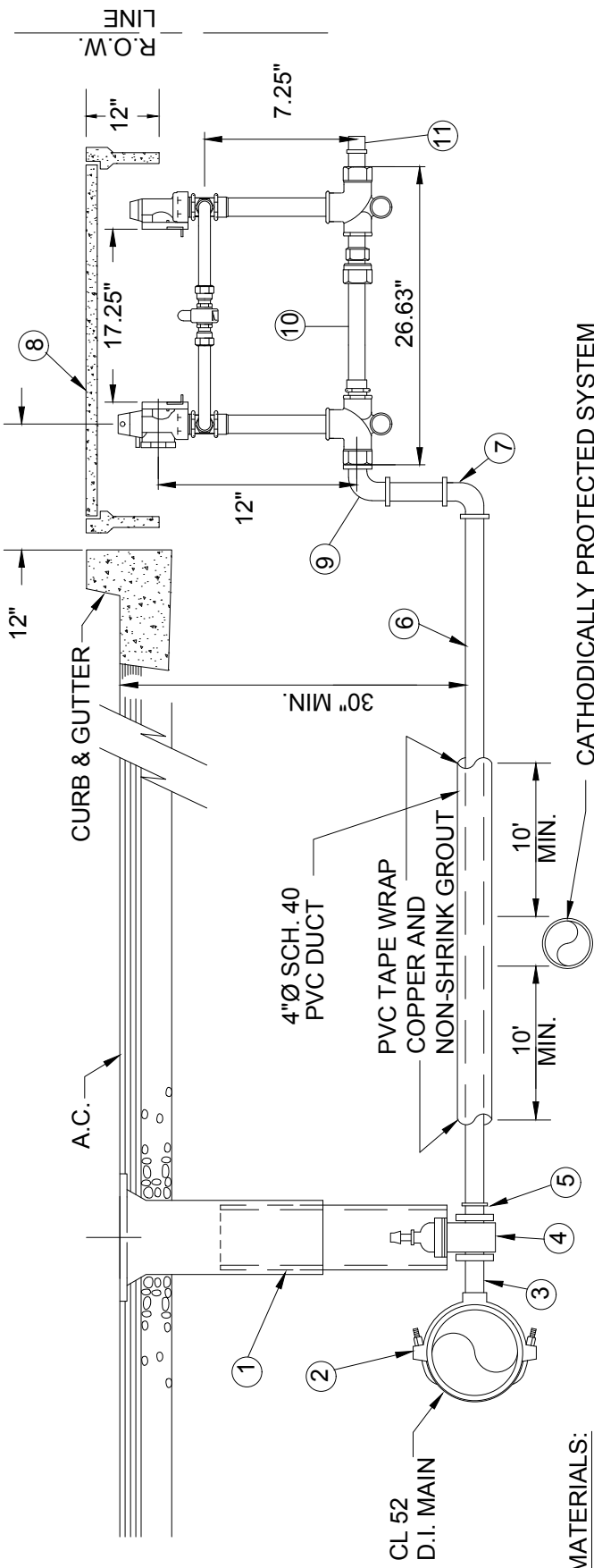

MATERIALS:

1. "VANCOUVER" STYLE VALVE BOX, (SEE DETAIL 511A).
2. ROMAC 202S DUCTILE BODY DUAL SS STRAPS OR APPROVED EQUAL.
3. 2" BRASS M.I.P. NIPPLE, 3" LENGTH.
4. 2" F.I.P. GATE VALVE (MUELLER NO. A-2360-8 OR APPROVED EQUAL).
5. 2" M.I.P. x MUELLER 110 COMPRESSION COUPLING (NO. H-15428N) OR APPROVED EQUAL.
6. 2" ASTM B88 TYPE "K" RIGID COPPER TUBING.
7. 2" 90° BEND, MUELLER 110 COMPRESSION (NO. H-15526N) OR APPROVED EQUAL.
8. DFW PLASTICS, INC. METER BOX (DFW1730CNP4-12-BODY) WITH NO PIPE HOLES AND COVER (SEE STANDARD DETAIL 515B)
9. 2" 90° BEND, COMP. x M.I.P. (MUELLER H-15531N) OR APPROVED EQUAL.
10. 2" METER YOKE (SETTER) (MUELLER NO. B-2423-99000N), OR APPROVED EQUAL.
11. THREADED PVC PLUG.

NOTES:

1. SUBSTITUTES FOR ANY MATERIALS SHOWN MAY BE APPROVED BY THE CITY ENGINEER.
2. ALL PIPE AND STRUCTURE ZONES SHALL BE BACKFILLED USING 3/4"-MINUS CRUSHED AGG. AND COMPACTED TO 95% MAX. DENSITY AS DETERMINED BY ASTM D1557.
3. WHEN AN ACTIVE CATHODIC PROTECTION SYSTEM, IS ENCOUNTERED WITH COPPER SERVICES, SCH. 40 PVC SHALL BE INSTALLED WITH IMPERVIOUS PLUGS, AS SHOWN.
4. METER BOX SHALL BE CENTERED OVER THE COMPLETED METER AND FITTING ASSEMBLY.
5. CUSTOMER SHALL INSTALL AN APPROVED BACKFLOW PREVENTION ASSEMBLY AT RIGHT-OF-WAY.
6. METER SETTER SHALL BE PERPENDICULAR TO CURB LINE.
7. 2" TAPS TO BE DONE WITH 1-7/8" HOLE SAW USING TAPPING MACHINE.

CATHODICALLY PROTECTED SYSTEM

DRAWN	KRB
REV. DATE	MAY 2026
APPR.	
DETAIL NO.	503

PLAN

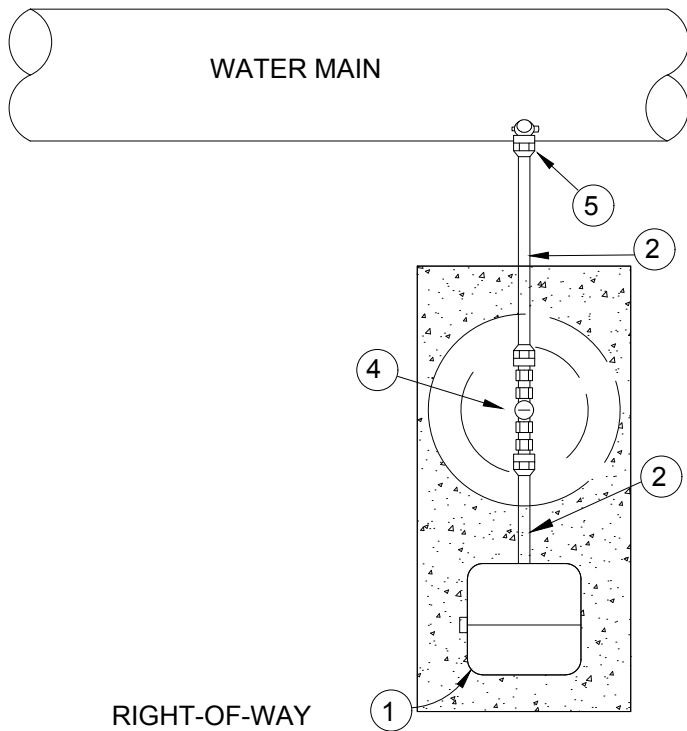

MATERIALS

- ①. KUPFERLE ECLIPSE NO. 88-SS SAMPLING STATION WITH STAINLESS STEEL STANDPIPE, NON THREADED STAINLESS STEEL SAMPLING BIBB (EXTERIOR) AND 1/4" VALVE ON DRAIN LINE. DOOR OPENING PERPENDICULAR TO STREET OR SIDEWALK.
- ②. 3/4" TYPE "K" SOFT TEMPER COPPER TUBING.
- ③. 3/4" QUARTER BEND M.I.P. x COMP. MUELLER H-15531N(110 COMPRESSION) OR APPROVED EQUAL.
- ④. 3/4" COMPRESSION BALL VALVE, MUELLER B-25209N OR APPROVED EQUAL.
- ⑤. 3/4" BALL VALVE CORP. STOP, MUELLER B-25008N (110 COMPRESSION) OR APPROVED EQUAL.
- ⑥. "VANCOUVER" STYLE VALVE BOX (SEE DETAIL 511A). NOTCH PVC TO EXTEND 1" BELOW COPPER TUBING.
- ⑦. 4" THICK CONCRETE PAD 4" THK., X 46" LG X 31" WIDE.

ELEVATION

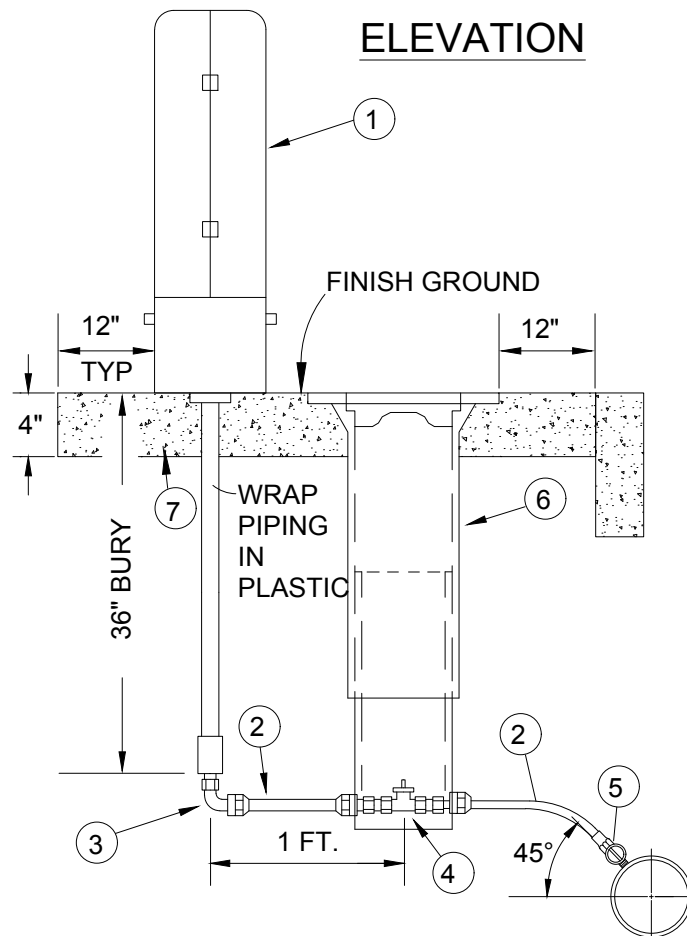

NOTES

1. ALL PIPE AND STRUCTURES SHALL BE BACKFILLED WITH 3/4"-0 CRUSHED ROCK COMPACTED TO MIN. 95% OF MAX. DENSITY PER ASTM D1557
2. SET STATION AT LOT LINE UNLESS OTHERWISE SPECIFIED.
3. WHEN CROSSING CATHODICALLY PROTECTED SYSTEM, INSTALL PVC SLEEVE PER DETAIL 502.
4. WHERE NO SIDEWALK EXISTS, PLACE CONC. PAD AS SHOWN. WHERE SIDEWALK EXIST., PLACE MIN. 12" AROUND BACK OF SAMPLE STA. AND INCORPORATE INTO NEW SIDEWALK POUR.
5. STOCK GREEN COLOR

CITY OF
GRESHAM

WATER SAMPLING STATION

PWS VERSION: JULY 2026

DRAWN SRS

REV. DATE MAY 2026

APPR.

DETAIL NO. 504

COMBINATION AIR VALVE UNIT SECTION

FOR SPECIFICATIONS OF AIR VALVE UNIT
SEE DETAIL 505B

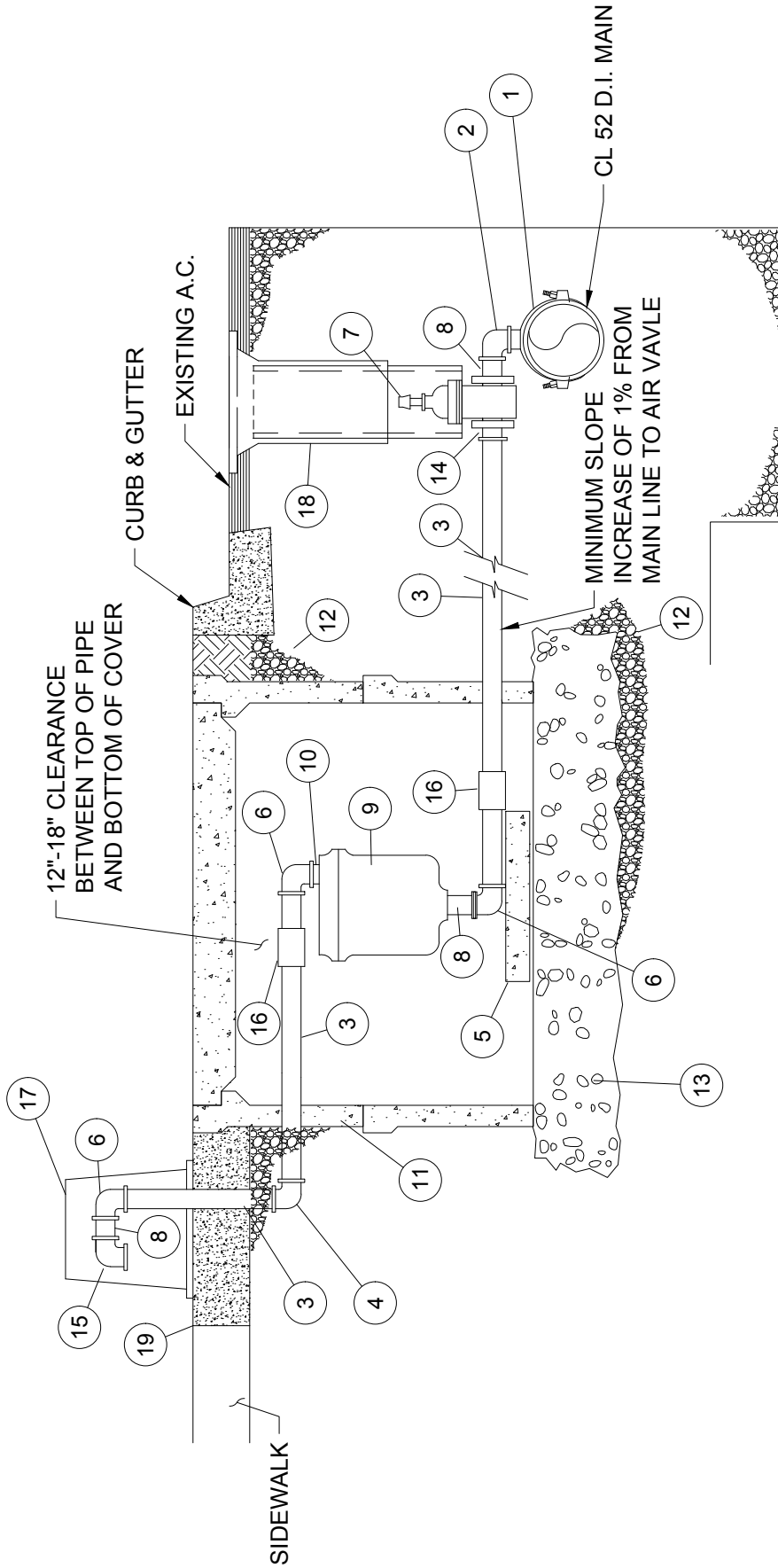

DRAWN	AAD
REV. DATE	AUG 2025
APPR.	
DETAIL NO.	505A

MATERIALS

1. ROMAC 202NS DUCTILE BODY DUAL SS STRAPS OR APPROVED EQUAL.
2. 2" BRASS STREET ELBOW.
3. 2" ASTM B88 RIGID COPPER, TYPE K.
4. 2" BRASS ¼ BEND, MUELLER 110 COMPRESSION H15526N OR APPROVED EQUAL.
5. 12"x12"x4" CONCRETE BLOCK.
6. 2" ¼ BEND, F.I.P. x 110 COMPRESSION, MUELLER NO. H15533N OR APPROVED EQUAL.
7. 2" R.W. F.I.P. GATE VALVE.
8. 2" x3" BRASS M.I.P. NIPPLE.
9. 2" COMBINATION AIR VALVE (VAL-MATIC NO. 202C.2 OR APCO NO. 145C-2 OR APPROVED EQUAL).
10. 2" x 1-½" BRASS M.I.P. NIPPLE.
11. JENSEN PRECAST HN1730X12 CONCRETE BOX WITH HPC 1730 SMC COVER AND HN1730-E CONCRETE BOX EXTENSION.
12. ¾"-MINUS CRUSHED AGGREGATE.
13. 1-½" - ¾" CLEAN DRAIN ROCK.
14. 2" COUPLING, M.I.P. x 110 COMPRESSION, MUELLER NO. H15428N OR APPROVED EQUAL.
15. 2" F.I.P. BRASS ¼ BEND WITH GALVANIZED SCREENING WITH ⅛" HOLES ON OUTLET.
16. 2" UNION, 110 COMPRESSION, MUELLER NO. H15403N OR APPROVED EQUAL.
17. HOT BOX EZ.75 EZ OR APPROVED EQUAL.
18. "VANCOUVER" STYLE VALVE BOX. SEE DETAIL 511A.
19. HOT BOX TO BE ON 4" THICK CONCRETE PAD, EXTENDING A MINIMUM OF 4" BEYOND THE BOX ON ALL SIDES

NOTES

1. INSTALLATION LOCATED AT HIGH POINT OF MAIN.
2. JENSEN PRECAST METER BOX HN1730X12 AND HPC 1730 SMC COVER OR APPROVED EQUAL.
3. ALL PIPE AND STRUCTURE ZONES SHALL BE COMPACTED TO 95% OF MAX. DENSITY AS DETERMINED BY ASTM D1557 OR AS SPECIFIED IN THE CONTRACT DOCUMENTS.
4. DETAIL NOT FOR SHALLOW INSTALLATIONS. INSTALLATIONS FOR WATERLINES WITH LESS THAN 36" OF COVER SHALL BE INDIVIDUALLY DESIGNED BY THE ENGINEER OF RECORD AND APPROVED BY THE CITY.
5. GROUT ALL AREAS WHERE COPPER PASSES THROUGH CONCRETE.
6. PLACE "HOT BOX" OR APPROVED EQUAL AT BACK OF SIDEWALK IN UTILITY EASEMENT OR OBTAIN 5' x 5' WATER FACILITY EASEMENT. SECURE HOT BOX TO CONCRETE.

**CITY OF
GRESHAM**

COMBINATION AIR VALVE NOTES

PWS VERSION: JULY 2026

DRAWN **AAD**

REV. DATE **MAY 2026**

APPR.

DETAIL NO. **505B**

FILENAME: y:\inter-departmental\development engineering projects\public works standards\2.0 pws revision copy\details\cad - all\500_water\506a.dwg, Plotted 4/20/2026 10:51 AM, By: Anthony Dollowitch, ANSI FULL BLEED A (8.50 X 11.00 INCHES)

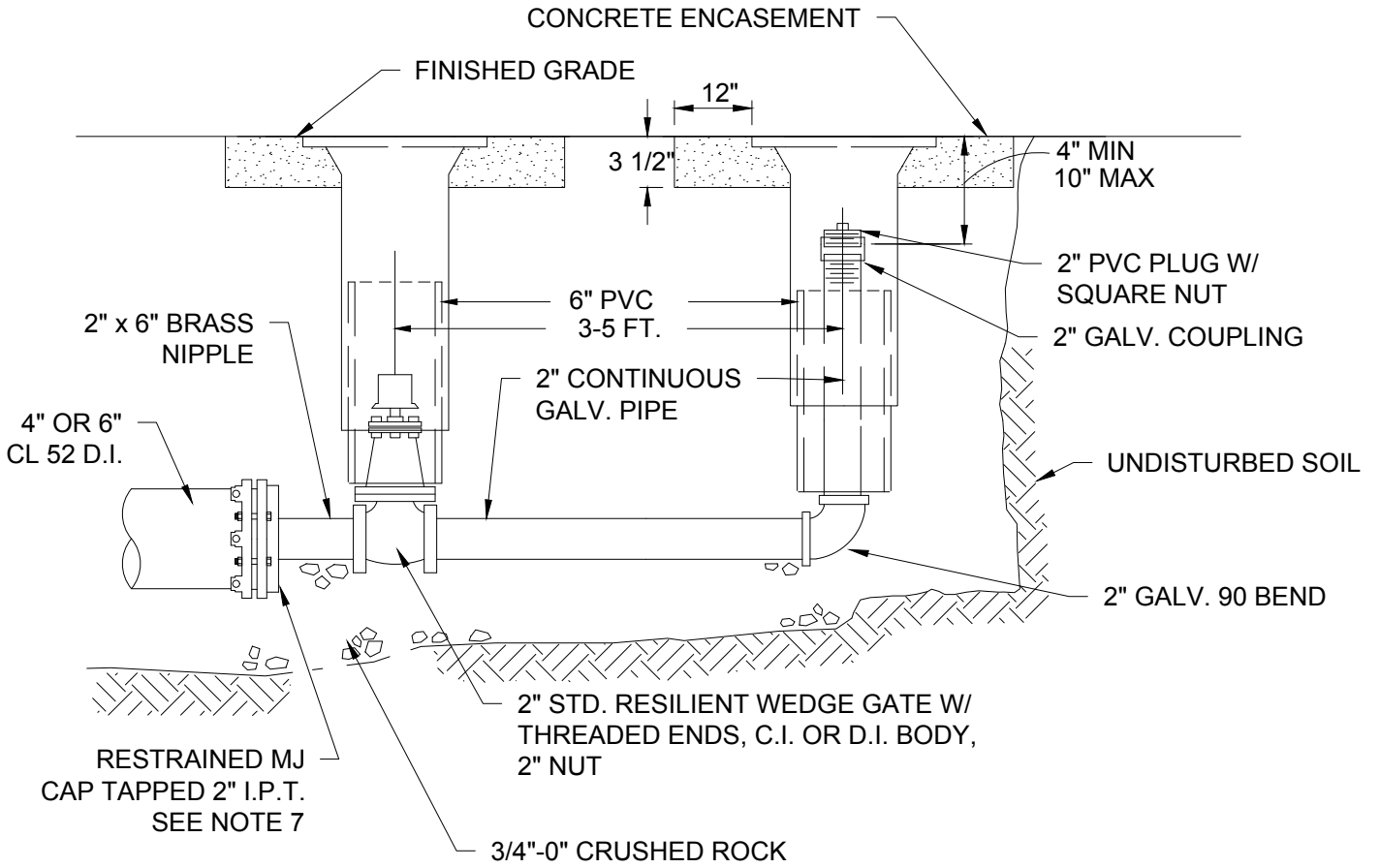

NOTES:

1. USE "VANCOUVER" STYLE VALVE BOXES, LIDS, AND 6" PVC EXTENSION (SEE DETAIL 511A)
2. VALVE BOXES TO BE CONCRETE ENCASED AS SHOWN IF NOT IN PAVED AREA.
3. BLOW-OFF UNIT SHALL BE BACKFILLED WITH 3/4"-0" CRUSHED ROCK AND COMPACTED TO 95% OF MAX. DENSITY AS DETERMINED BY ASTM D1557.
4. PLACE BLOW-OFF STANDPIPE 3 FT INSIDE R.O.W. LINE AT THE END OF STREET (2 FT. FROM BARRICADE).
5. 2" GALVANIZED TO BE ONE CONTINUOUS PIECE.
6. 2" PVC PLUG WITH SQUARE NUT TO BE HAND TIGHTENED ONLY.
7. ENTIRE BLOWOFF ASSEMBLY AND MAIN MUST BE RESTRAINED IN ACCORDANCE WITH PWS SECTION 5.01.

CITY OF GRESHAM

2" BLOWOFF ASSEMBLY

PWS VERSION: JULY 2026

DRAWN	SRS
REV. DATE	MAY 2026
APPR.	
DETAIL NO.	506A

NOTES:

1. BACKFILL WITH SELECT CRUSHED AGGREGATE A MINIMUM OF 6" ON ALL SIDES.
2. TEMPORARY BLOW-OFF IS ONE REMOVED AT THE END OF PROJECT CONSTRUCTION. A PERMANENT BLOW-OFF REMAINS ON THE PROJECT AFTER ACCEPTANCE.
3. PLACE BLOW-OFF STANDPIPE 3 FT. INSIDE P/L. LINE AT END OF STREET (2 FT. FROM BARRICADE).
4. USE "VANCOUVER" STYLE VALVE BOX, LID, AND 6" PVC RISER FOR BLOW-OFF VALVE. USE "PORTLAND" STYLE VALVE BOX, LID, AND 8" PVC RISER FOR BLOW-OFF STAND PIPE (SEE DETAILS 511A & 512)
5. ENTIRE BLOWOFF ASSEMBLY AND MAIN MUST BE RESTRAINED IN ACCORDANCE WITH PWS SECTION 5.01.

BLOW-OFF SIZES REQUIRED	
MAIN SIZE	BLOW-OFF SIZE
4" TO 6"	2"
8" TO 12"	4"
14" TO 18"	6"
20" & UP	PER ENGR.

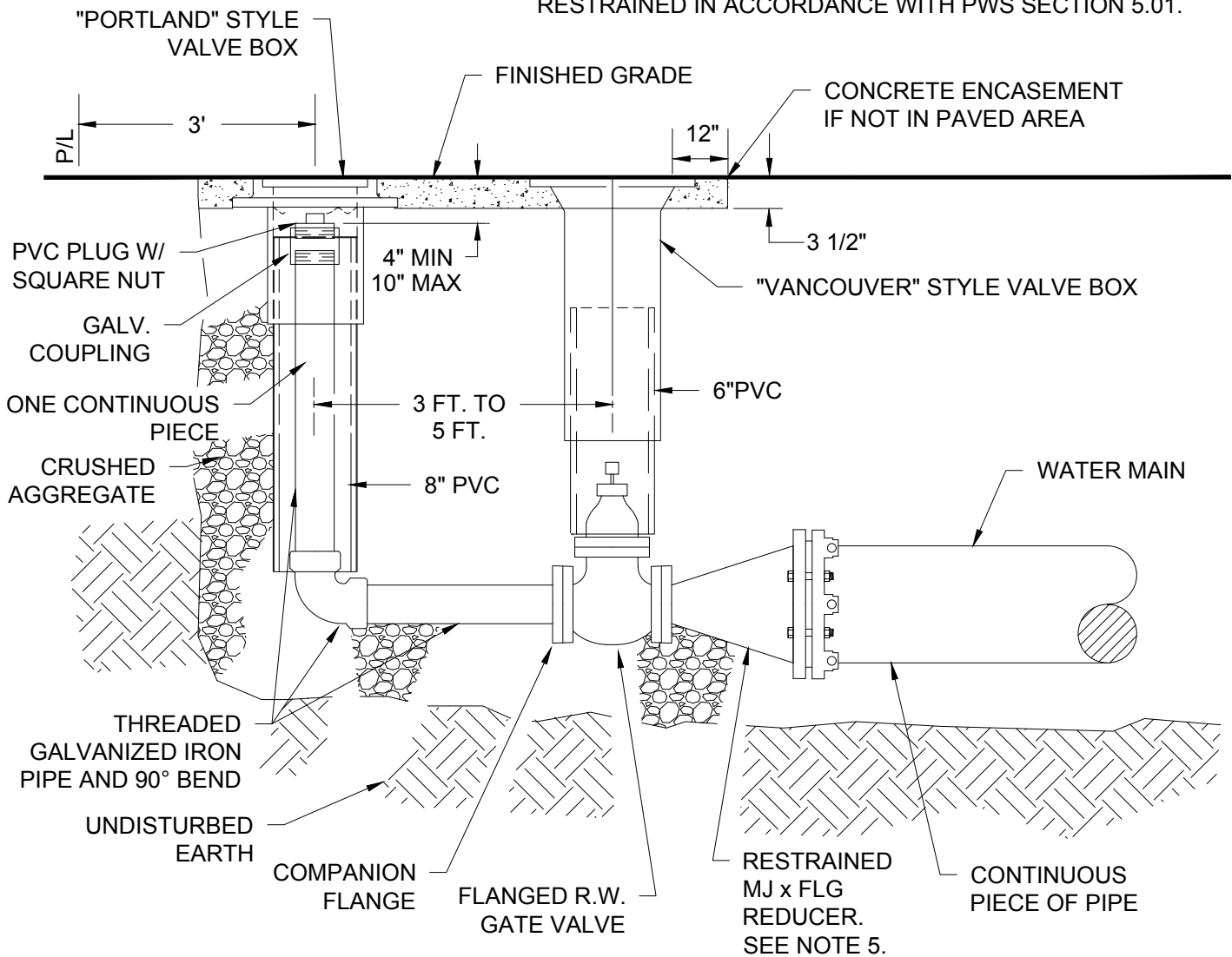

FILENAME: y:\inter-departmental\development engineering projects\public works standards\2.0 pws revision copy\details\cad - all\500_water\506b.dwg, Plotted 4/20/2026 10:51 AM, By: Anthony Dollowitch, ANSI FULL BLEED A (8.50 X 11.00 INCHES)

CITY OF GRESHAM

4" OR 6" BLOWOFF ASSEMBLY

PWS VERSION: JULY 2026

DRAWN	SRS
REV. DATE	MAY 2026
APPR.	
DETAIL NO.	506B

FILENAME: y:\inter-departmental\development_engineering_projects\public_works_standards\2.0_pws_revision_copy\details\cad - all\500_water\506c.dwg. Plotted 4/20/2026 10:51 AM, By: Anthony Dolowitch, ANSI FULL BLEED A (8.50 X 11.00 INCHES)

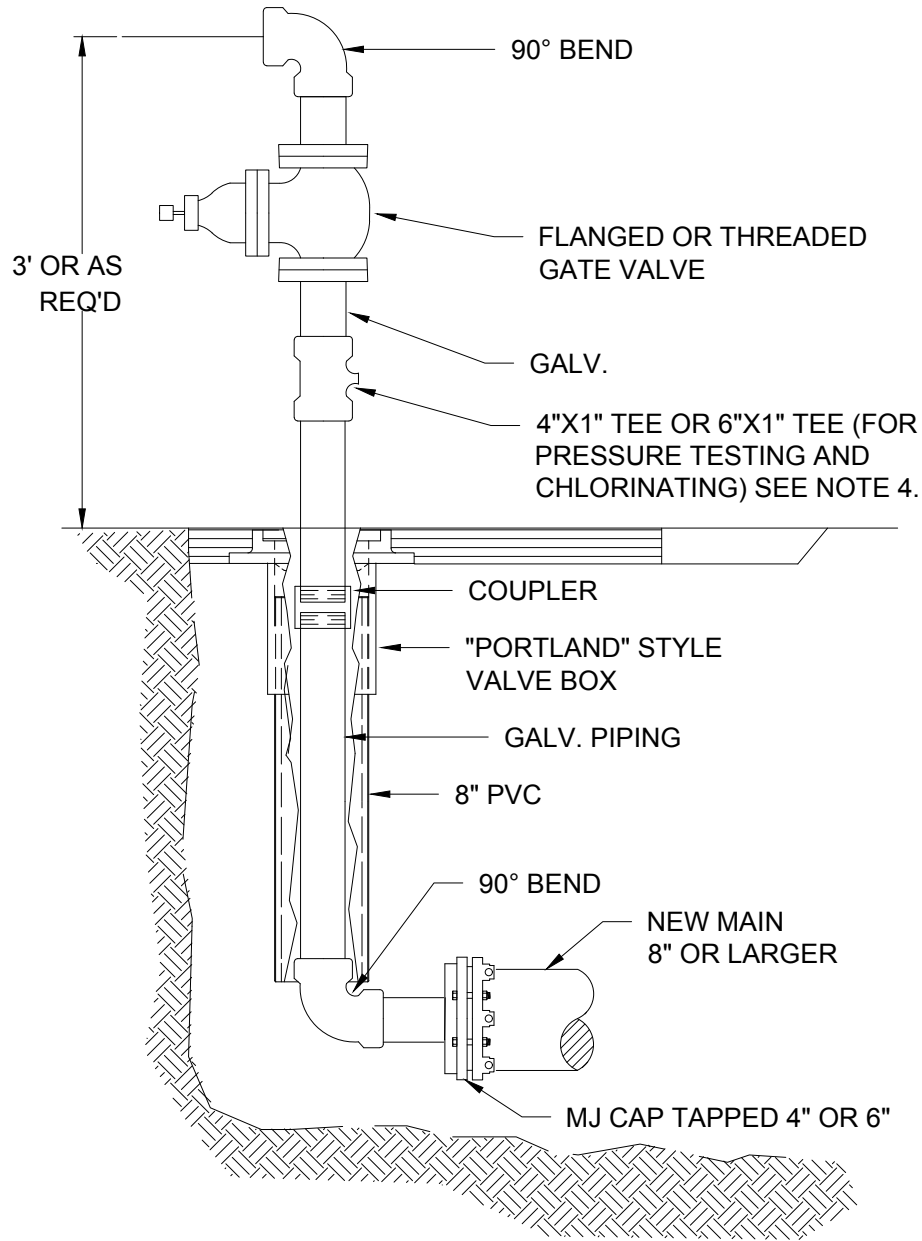

NOTES:

1. ALL FILLING, FLUSHING, AND TESTING OF NEW WATERLINE FACILITIES SHALL BE DONE THROUGH A 6" DOUBLE CHECK ASSEMBLY WITH A METERING DEVICE.
2. PROVIDE TEMPORARY BLOCKING AS REQUIRED.
3. ALL PIPING AND FITTINGS SHALL BE GALVANIZED IRON.
4. FOR 8"-12" WATERLINES: FILL POINT SHALL BE 4" PIPING AND FITTINGS. FOR 14"-18" WATERLINES: FILL POINT SHALL BE 6" PIPING AND FITTINGS. FOR 20" AND LARGER: FILL POINT SHALL BE SIZED AS DETERMINED BY THE ENGINEER.

**CITY OF
GRESHAM**

4" OR 6" TEMPORARY FILL POINT

PWS VERSION: JULY 2026

DRAWN SRS

REV. DATE JAN 2020

APPR.

DETAIL NO. 506C

THRUST BLOCKS ARE ONLY ALLOWED IN LIMITED CIRCUMSTANCES IN ACCORDANCE WITH PWS SECTION 5.01.

BEARING AREA OF THRUST BLOCKS (sq. ft.)						
FITTING SIZE (inches)	TEE & WYE ①	STRADDLE BLOCK ②	90° BEND PLUGGED CROSS TEE PLUGGED-RUNS ③	45° BEND ④	22 1/2° BEND ④	11 1/4° BEND ④
2	*	*	*	*	*	*
4	2.5	2.5	3.6	1.9	*	*
6	5.7	5.7	8.0	4.3	2.2	*
8	10.1	10.1	14.2	7.7	3.9	2.0
10	15.7	15.7	22.2	12.0	6.1	3.1
12	22.6	22.6	32.0	17.3	8.8	4.4
16	40.2	40.2	56.9	30.8	15.7	7.9
18	50.9	50.9	72.0	39.0	19.9	10.0
LARGER	**	**	**	**	**	**

* BLOCK TO UNDISTURBED TRENCH WALLS

** THRUST BLOCKS FOR PIPES LARGER THAN 18" WILL BE INDIVIDUALLY DESIGNED BY THE ENGINEER OF RECORD.

- ALL VALUES ARE BASED ON THE FOLLOWING ASSUMPTIONS:
AVG. PRESSURE = 150 PSI x 2 (safety factor); 1500 PSF SOIL BEARING CAPACITY; NORMAL DISTRIBUTION DESIGN VELOCITY NOT TO EXCEED 8 F/S.
- ALL FITTINGS SHALL BE WRAPPED IN PLASTIC PRIOR TO PLACEMENT OF CONCRETE.
- ALL THRUST BLOCKS SHALL BE FORMED TO ELIMINATE ANY CONCRETE AROUND FITTING BOLTS.
- BEARING SURFACE OF THRUST BLOCKING SHALL BE AGAINST UNDISTURBED SOIL.
- ALL CONCRETE MIX SHALL HAVE A MIN. 28 DAY STRENGTH OF 4,000 PSI.
- ALL PIPE ZONES SHALL BE GRAVEL FILLED AND COMPACTED.
- THRUST BLOCKS FOR PLUGGED CROSS AND PLUGGED TEE SHALL HAVE #4 REBAR LIFTING LOOPS INSTALLED AS SHOWN.
- VERTICAL THRUST DETAILS - SEE DETAIL 508
- STRADDLE BLOCK DETAILS - SEE DETAIL 509
- EACH PROPOSED MECHANICAL RESTRAINT LENGTHS SHALL BE REVIEWED ON A CASE BY CASE BASIS BY THE ENGINEER OF RECORD.

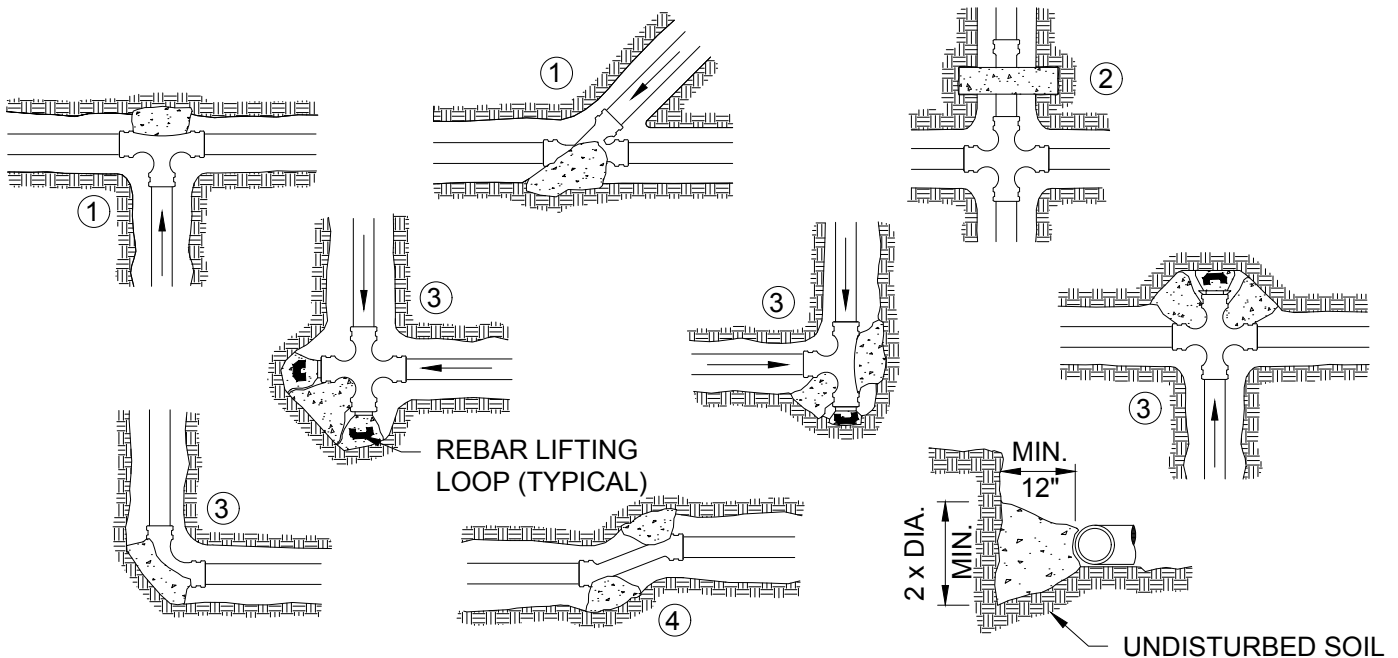

CITY OF GRESHAM

HORIZONTAL THRUST BLOCKING

PWS VERSION: JULY 2026

DRAWN	KRB
REV. DATE	MAR 2021
APPR.	
DETAIL NO.	507

THRUST BLOCKS ARE ONLY ALLOWED IN LIMITED CIRCUMSTANCES IN ACCORDANCE WITH PWS SECTION 5.01.

NOTES:

1. GRAVITY VERTICAL THRUST BLOCKS AND MECHANICAL RESTRAINT LENGTH VALUES SHALL BE REVIEWED BY THE ENGINEER OF RECORD.
2. KEEP CONCRETE CLEAR OF JOINT AND JOINT ACCESSORIES. FITTINGS SHALL BE WRAPPED IN PLASTIC PRIOR TO PLACEMENT OF CONCRETE.
3. CONCRETE THRUST BLOCKING SHALL BE POURED AGAINST UNDISTURBED EARTH.
4. CONCRETE MIX SHALL HAVE A MIN. 28 DAY STRENGTH OF 4,000 P.S.I.
5. GRAVITY THRUST BLOCK VOLUMES FOR VERTICAL BENDS HAVING UPWARD RESULTANT THRUSTS ARE BASED ON TEST PRESSURE OF 150 P.S.I.G. X 2 FACTOR OF SAFETY AND THE WEIGHT OF CONCRETE = 4050 LBS./CU.YD.
6. VERTICAL BENDS THAT REQUIRE A GRAVITY THRUST BLOCK VOLUME EXCEEDING 5 CUBIC YARDS REQUIRE SPECIAL BLOCKING DETAILS DESIGNED BY THE ENGINEER OF RECORD. NOTE VOLUMES SHOWN INSIDE HEAVY LINE IN TABLE.
7. ALL REBAR SHALL BE GALVANIZED IN ACCORDANCE WITH ASTM-123 (MIN. 3.4 MIL). REBAR SHALL BE BENT BEFORE GALVANIZATION, AND LAST 4" OF BAR SHALL BE BENT 90 DEGREES WITH A 1/2" RADIUS BEND. REBAR SHALL BE TIGHTLY FIT TO RESTRAINED FITTING.
8. FOR HORIZONTAL THRUST BLOCK DETAILS SEE DETAIL 507.

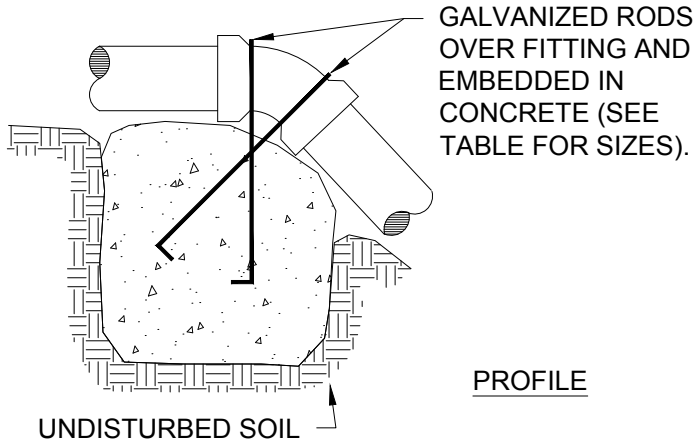

GRAVITY VERTICAL THRUST BLOCK

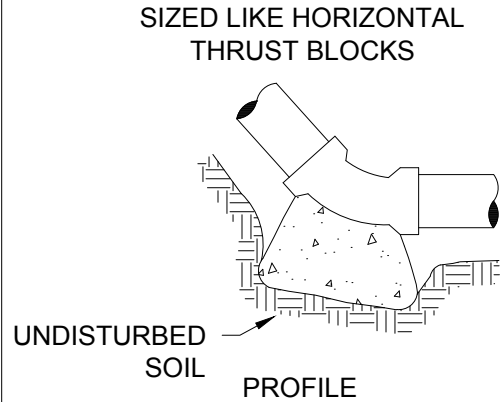

NORMAL VERTICAL THRUST BLOCK

VOLUME OF GRAVITY THRUST BLOCK IN CUBIC YARDS (VERTICAL BENDS)			
FITTING SIZE	BEND ANGLE		
	45°	22 1/2°	11 1/4°
4	0.7	0.4	0.2
6	1.5	0.8	0.4
8	2.6	1.4	0.7
10	4.1	2.2	1.1
12	5.9	3.2	1.6
14	8.1	4.4	2.2
16	10.5	5.7	2.9

FITTING SIZE	ROD SIZE	EMBEDMENT
12" AND LESS	#6	30"
14" - 16"	#8	36"

CITY OF GRESHAM

VERTICAL THRUST BLOCKING

PWS VERSION: JULY 2026

DRAWN KRB

REV. DATE MAR 2021

APPR.

DETAIL NO. 508

STRADDLE BLOCKS ARE ONLY ALLOWED IN LIMITED CIRCUMSTANCES IN ACCORDANCE WITH PWS SECTION 5.01.

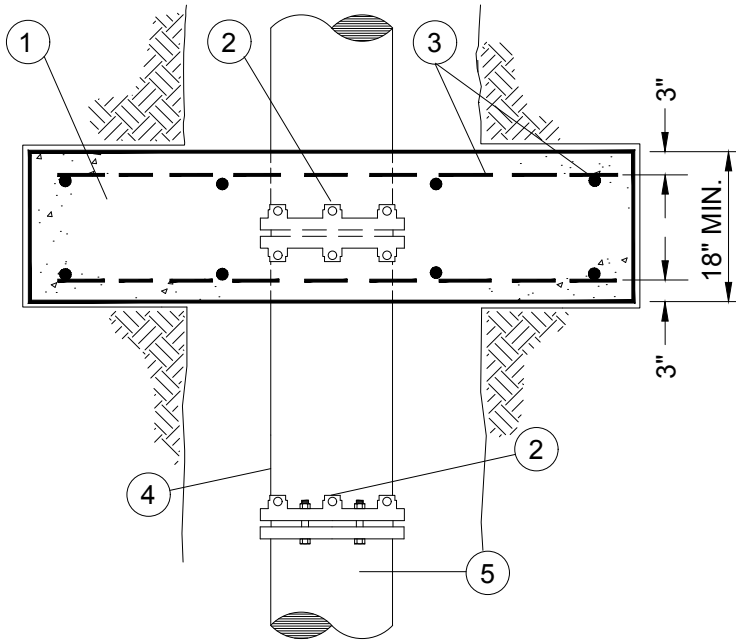

TOP VIEW

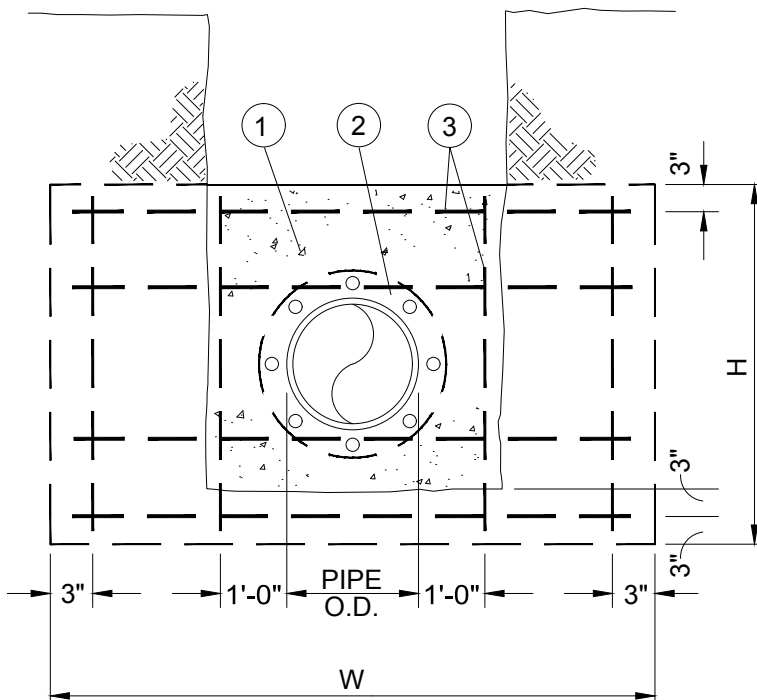

FRONT VIEW

MATERIALS:

- ① CONCRETE STRADDLE BLOCK
- ② 2-MEGALUGS OR APPROVED EQUAL RETAINER GLANDS
- ③ #4 REBAR EACH WAY, 12" O/C.
- ④ NO JOINTS ALLOWED BETWEEN STRADDLE BLOCK AND FITTING/BLOW-OFF ASSEMBLY
- ⑤ FITTING/BLOW-OFF ASSEMBLY

NOTES:

1. STRADDLE BLOCKS HEIGHT (H) AND WIDTH (W) SHALL BE DESIGNED INDIVIDUALLY BY THE ENGINEER OF RECORD AND SHALL BE BASED ON THE FOLLOWING:
 - a.) WATER PRESSURE = 150 PSI X 2 (SAFETY FACTOR)
 - b.) SOIL BRG. CAPACITY
 - c.) STEEL SIZE AND SPACING
2. BEARING AREA OF BLOCK SHALL BE AGAINST UNDISTURBED SOIL.
3. STRADDLE BLOCK SHALL HAVE A MINIMUM OF 18" COVER.
4. CONCRETE SHALL HAVE A MIN. 28-DAY STRENGTH OF 4,000 PSI.
5. ALL FITTINGS & PIPE WITHIN THE CONC. SHALL BE WRAPPED IN 8 MIL. PLASTIC.

FILENAME: y:\inter-departmental\development engineering projects\public works standards\2.0 pws revision copy\details\cad - all\500_water\509.dwg. Plotted 4/20/2025 10:51 AM. By: Anthony Dollowitch, ANSI FULL BLEED A (8.50 X 11.00 INCHES)

CITY OF GRESHAM

STRADDLE BLOCK

PWS VERSION: JULY 2026

DRAWN	SRS
REV. DATE	MAR 2021
APPR.	
DETAIL NO.	509

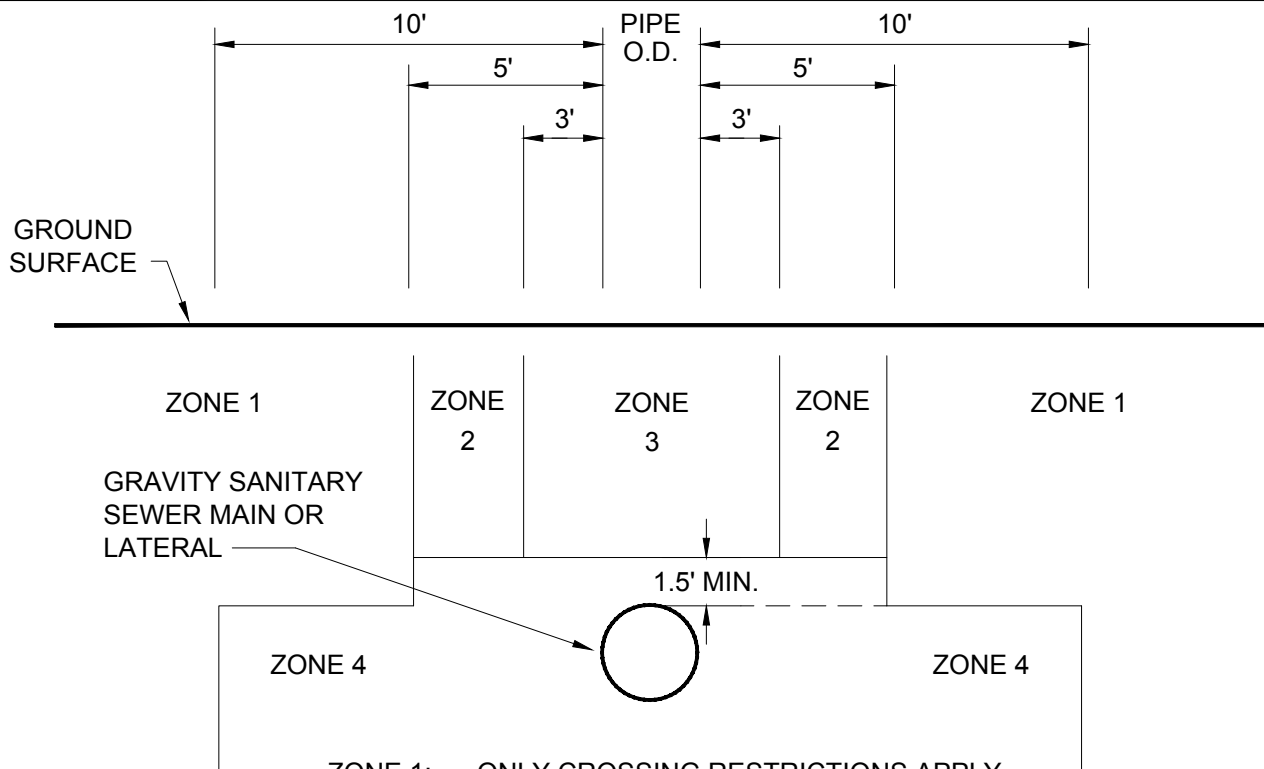

- ZONE 1: ONLY CROSSING RESTRICTIONS APPLY
- ZONE 2: CASE-BY CASE DETERMINATION
- ZONE 3: PARALLEL WATERLINE PROHIBITED
- ZONE 4: PARALLEL WATERLINE PROHIBITED

NOTES:

1. WHERE THE PROPOSED WATERLINE WILL BE INSTALLED PARALLEL TO AN EXISTING GRAVITY SANITARY SEWER MAIN OR LATERAL LINE, THE SEPARATION BETWEEN THE TWO SHALL BE AS INDICATED ABOVE.
2. CROSSING:
 - a. WHENEVER POSSIBLE, THE BOTTOM OF THE WATERLINE SHALL BE 1.5 FEET ABOVE THE TOP OF THE SANITARY SEWER LINE.
 - b. WHERE IT IS NOT POSSIBLE FOR THE WATERLINE TO BE 1.5 FEET ABOVE THE SANITARY SEWER LINE, OR THE WATERLINE PASSES UNDER THE SEWER LINE, THE EXISTING SEWER LINE SHALL BE EXPOSED FOR A DISTANCE OF 10 FEET ON EACH SIDE OF THE CROSSING, AND SHALL BE REPLACED WITH C-900 PVC, DR-18, DR-25 OR CLASS 50 DUCTILE IRON PIPE AS APPROVED BY THE ENGINEER, AND A LENGTH OF WATER PIPE SHALL BE CENTERED AT THE CROSSING, OR AS APPROVED BY THE ENGINEER.
3. SEPARATION FROM FORCE MAIN SANITARY SEWER SHALL BE REVIEWED ON A CASE-BY-CASE BASIS WHEN IN ZONES 2, 3, AND 4.

FILENAME: y:\inter-departmental\development_engineering_projects\public_works_standards\2.0_pws_revision_copy\details\cad - all\500_water\510.dwg, Plotted 4/20/2025 10:51 AM, By: Anthony Dollowitch, ANSI FULL BLEED A (8.50 X 11.00 INCHES)

DRAWN	AAD
REV. DATE	AUG 2025
APPR.	
DETAIL NO.	510

FILENAME: y:\inter-departmental\development engineering projects\public works standards\2.0 pws revision copy\details\cad - all\500_water\511a.dwg, Plotted 4/20/2026 10:51 AM, By: Anthony Dollowitch, ANSI FULL BLEED A (8.50 X 11.00 INCHES)

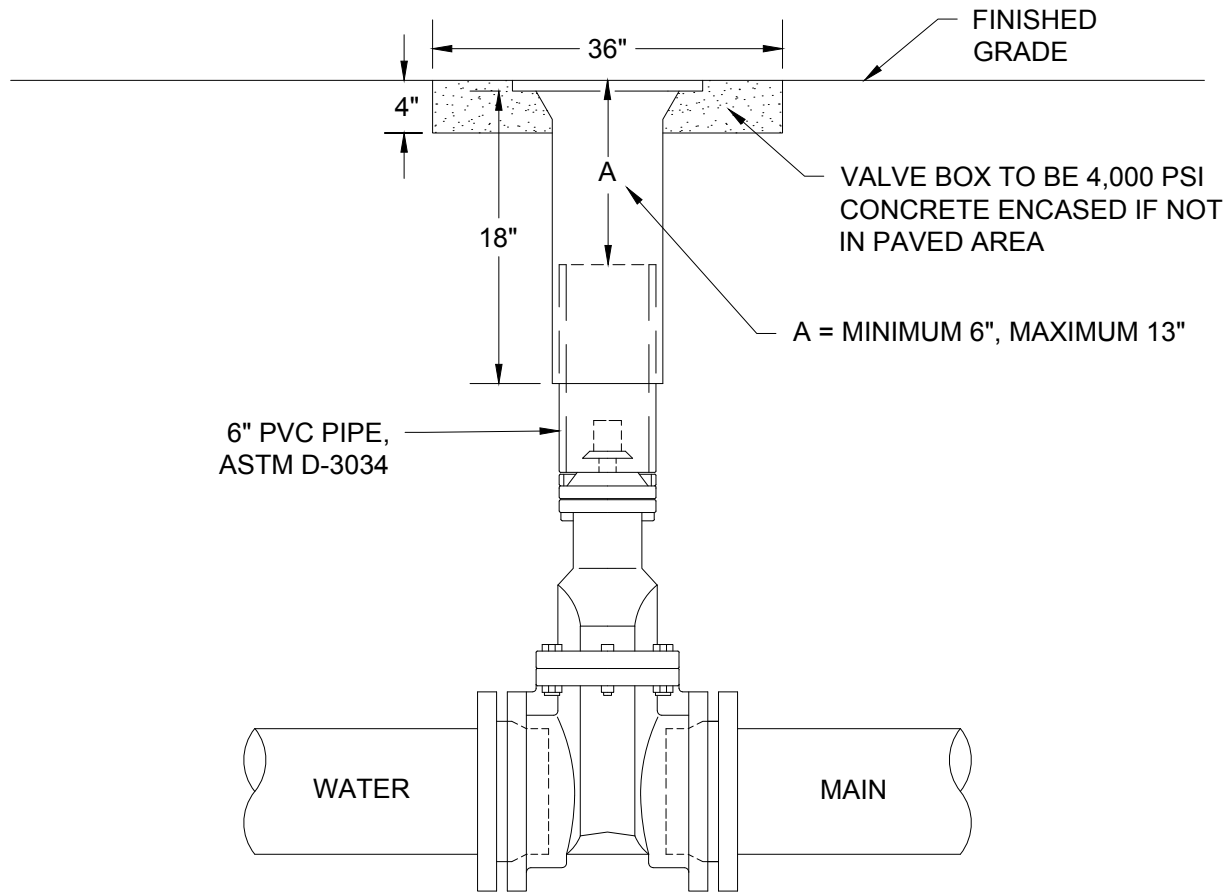

6" PVC PIPE,
ASTM D-3034

WATER

MAIN

NOTES:

1. VALVE BOXES SHALL BE CENTERED DIRECTLY OVER THE VALVE NUT IN A VERTICAL POSITION.
2. VALVE BOX TOP SHALL BE ADJUSTED TO MEET FINISH GRADE.
3. PVC SHALL BE ONE CONTINUOUS PIECE - NO BELLS OR COUPLERS.
4. USE FOR ALL VALVES AND 2" BLOW-OFF STANDPIPES.
5. NO NOTCHES SHALL BE CUT INTO VALVE BOX UNLESS BY CITY STAFF.
6. NOTCH PVC AT YOLK BOLTS WHERE REQUIRED
7. WHEN VALVE NUT IS DEEPER THAN 4' FROM FINISHED GRADE A VALVE OPERATOR EXTENSION IS REQUIRED, SEE DETAIL 511B

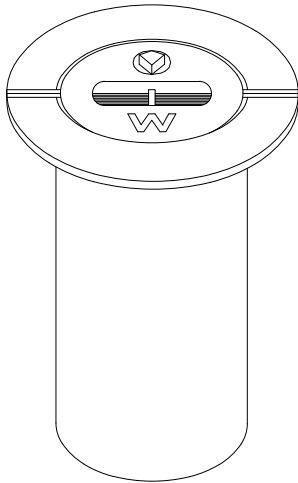

18" TALL CAST IRON VALVE BOX,
"VANCOUVER" STYLE, MODEL NO 910 OR
APPROVED EQUAL - WITH "W" CAST ON THE
COVER.

**CITY OF
GRESHAM**

"VANCOUVER" STYLE VALVE BOX

PWS VERSION: JULY 2026

DRAWN **AAD**

REV. DATE **MAY 2026**

APPR.

DETAIL NO. **511A**

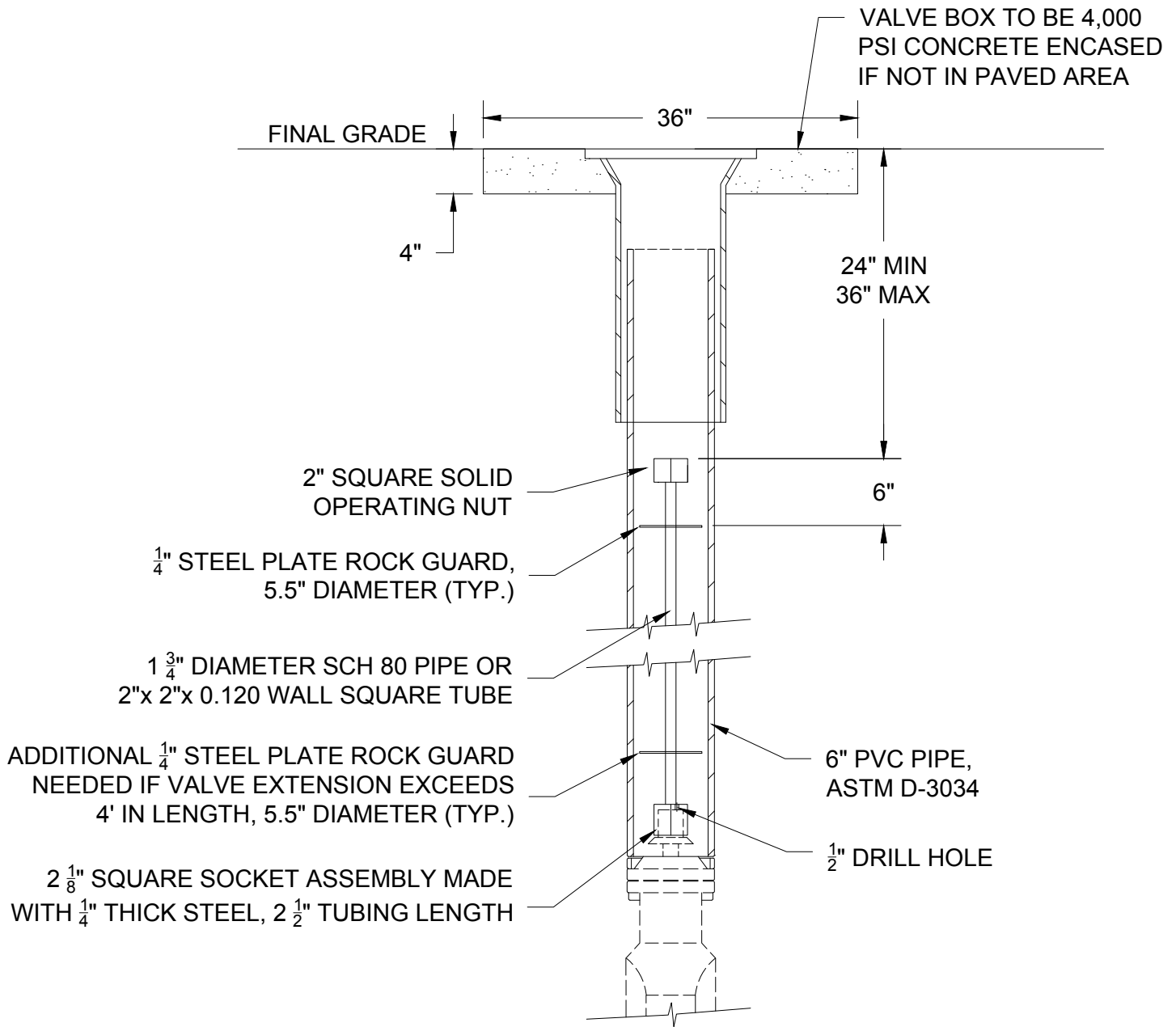

NOTES:

1. OPERATOR EXTENSION REQUIRED WHEN VALVE NUT IS DEEPER THAN 4' FROM FINISHED GRADE
2. VALVE OPERATOR SHALL BE MADE WITH A36 STEEL CENTER AND SQUARE ALONG CENTER AXIS, HOT DIP GALVANIZED AFTER FABRICATION

CITY OF
GRESHAM

VALVE OPERATOR EXTENSION

PWS VERSION: JULY 2026

DRAWN CLL

REV. DATE MAY 2026

APPR.

DETAIL NO. 511B

FILENAME: y:\inter-departmental\development engineering projects\public works standards\2.0 pws revision copy\details\cad - all\500_water\512.dwg. Plotted 4/20/2025 10:51 AM. By: Anthony Dollowitch, ANSI FULL BLEED A (8.50 X 11.00 INCHES)

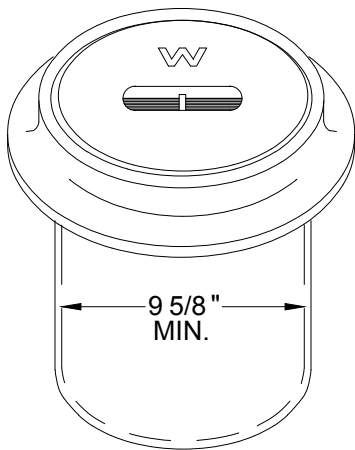
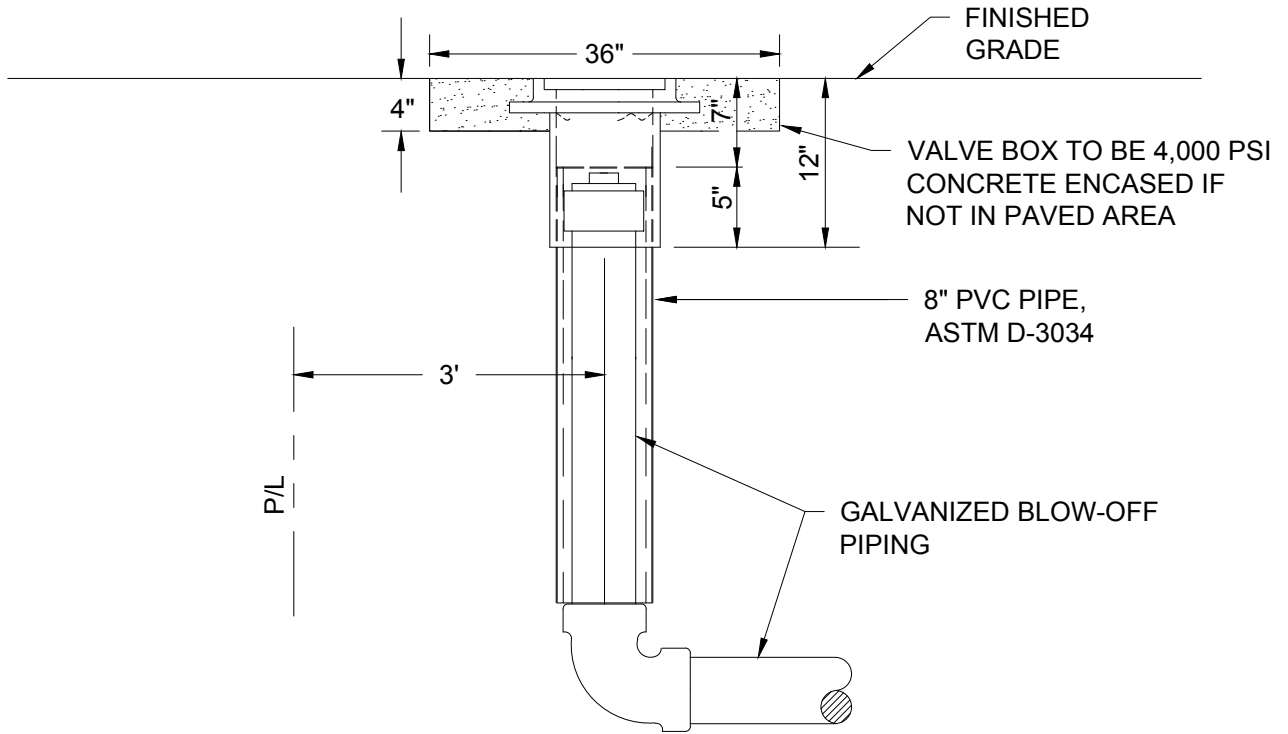

CAST IRON "PORTLAND" STYLE VALVE BOX

NOTES:

1. VALVE BOXES SHALL BE CENTERED DIRECTLY OVER THE STANDPIPE IN A VERTICAL POSITION.
2. VALVE BOX TOP SHALL BE ADJUSTED TO MEET FINISHED GRADE.
3. PVC SHALL BE ONE CONTINUOUS PIECE-NO BELLS OR COUPLERS.
4. USE FOR 4" AND 6" BLOW-OFF STANDPIPES AND FLUSH MOUNTED CATHODIC PROTECTION TEST STATIONS ONLY.
5. NO NOTCHES SHALL BE CUT INTO VALVE BOX UNLESS BY CITY STAFF.

DRAWN	AAD
REV. DATE	OCT 2025
APPR.	
DETAIL NO.	512

STREET SIDE

CUSTOMER SIDE

PLAN

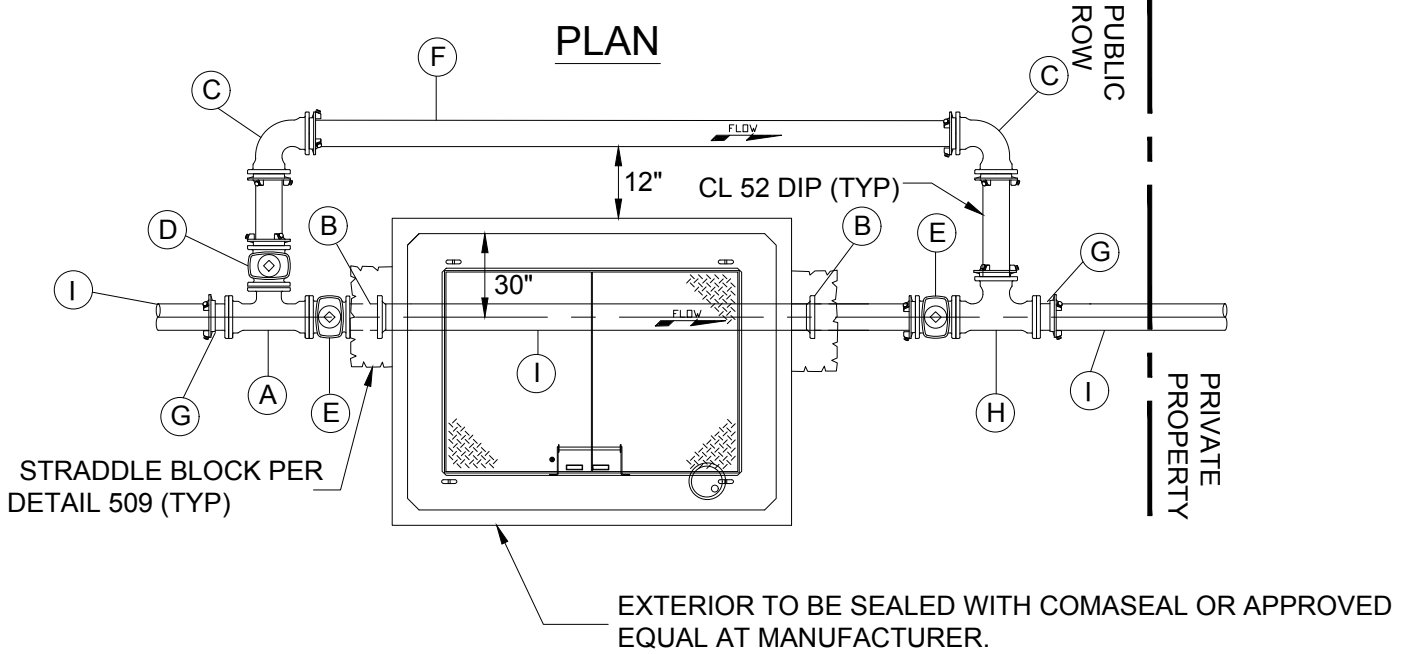

ELEVATION

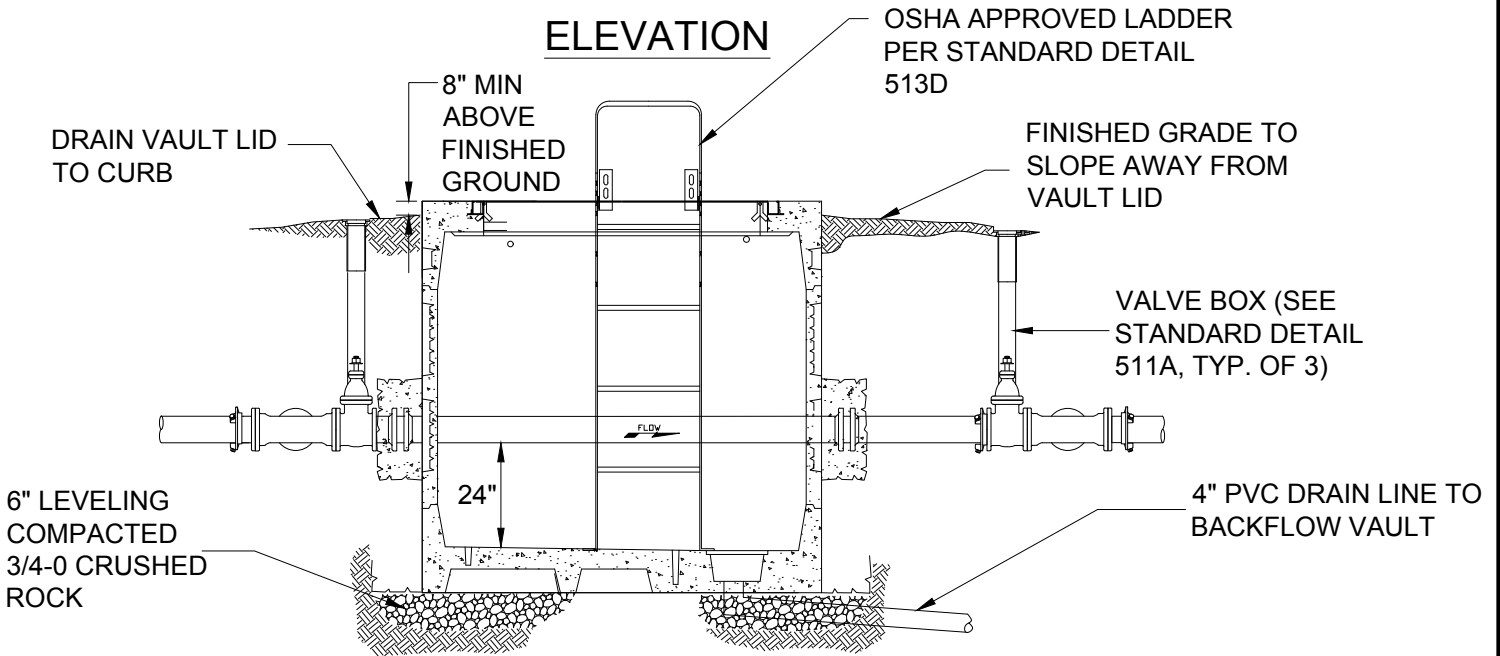

NOTES:

1. ALL MATERIALS SHALL BE AS NAMED OR APPROVED EQUAL. SUBMIT ALTERNATES FOR APPROVAL.
2. VAULTS AND PIPING SHALL NOT BE PLACED WITHIN 1-FOOT OF A SURVEY MARKER.
3. WHENEVER VAULTS ARE LOCATED IN PEDESTRIAN WALKWAYS APPLY SLIPNOT ON ALL VAULT LID SURFACES.
4. VAULT TO BE SMOOTH WALLED WITH NO KNOCK-OUT PANELS
5. HOLES IN VAULT TO BE CORE DRILLED AND ALL OPENINGS SHALL BE SEALED W/ NON-SHRINK GROUT
6. IF SOIL CONDITIONS ARE SUITABLE, INFILTRATION OF SUMP DRAINAGE MAY BE APPROVED ON A CASE BY CASE BASIS.
7. SEE STD. DETAIL 513B AND 513C FOR CONSTRUCTION NOTES AND SPECIFICATIONS

CITY OF GRESHAM

3" THROUGH 8" METER VAULT AND PIPING

PWS VERSION: JULY 2026

DRAWN KRB

REV. DATE MAY 2026

APPR.

DETAIL NO. 513A

FILENAME: y:\inter-departmental\development engineering projects\public works standards\2.0 pws revision copy\details\cad - all\500_water\513b.dwg, Plotted 4/20/2026 10:51 AM, By: Anthony Dollowitch, ANSI FULL BLEED A (8.50 X 11.00 INCHES)

SPECIFICATIONS

METER	3" METER	4" METER	6" METER	8" METER
INCOMING LINE SIZE	4"	4"	6"	8"
BY-PASS LINE SIZE	4"			
OLD CASTLE NO.	577-SLD (OR APPROVED EQUAL)			
LID NO. (OR APPROVED EQUAL)	57 TOP W/ USF-TPD-3660 ALUMINUM DOOR			

FITTINGS & VALVES BY CONTRACTOR

METERS	3"	4"	6"	8"
Ⓐ	4" FLG TEE	4" FLG TEE	6"x4" FLG TEE	8"x4" FLG TEE
Ⓑ	4" MEGA-LUG	4" MEGA-LUG	6" MEGA-LUG	8" MEGA-LUG
Ⓒ	4" MJ 90° BEND			
Ⓓ	4" VALVE FLG x MJ			
Ⓔ	4" VALVE FLG x MJ	4" VALVE FLG x MJ	6" VALVE FLG x MJ	8" VALVE FLG x MJ
Ⓕ	4" DIP CL 52			
Ⓖ	4" MJxFLG ADAPTER	4" MJxFLG ADAPTER	6" MJxFLG ADAPTER	8" MJxFLG ADAPTER
Ⓗ	4" FLG x MJ TEE	4" FLG x MJ TEE	6" x 4" FLG x MJ TEE	8" x 4" FLG x MJ TEE
Ⓘ	4" DIP CL 52	4" DIP CL 52	6" DIP CL 52	8" DIP CL 52

FITTINGS & METER BY CITY

METER	3"	4"	6"	8"
1	(2) 4" MJ x 3" FLG REDUCERS	(2) 4" MJ x FLG ADAPTERS	(2) 6" MJ x FLG ADAPTERS	(2) 8" MJ x FLG ADAPTERS
2	3" SENSUS METER (OR APPROVED EQUAL)	4" SENSUS METER (OR APPROVED EQUAL)	6" SENSUS METER (OR APPROVED EQUAL)	8" SENSUS METER (OR APPROVED EQUAL)



**3" THROUGH 8" METER VAULT AND PIPING
SPECS**

PWS VERSION: JULY 2026

DRAWN	SRS
REV. DATE	MARCH 2026
APPR.	
DETAIL NO.	513B

NOTES:

1. METER TO BE INSTALLED BY THE CITY ONCE NEW PIPING AND FITTINGS HAVE BEEN TESTED AND ACCEPTED.
2. INSTALL 4" DRAIN FROM BOTTOM OF VAULT FLOOR TO DAYLIGHT, TO BACKFLOW ASSEMBLY VAULT, OR TO APPROVED LOCATION. IN NO CASE SHALL BACKFLOW VAULT DRAIN INTO METER VAULT.
3. VAULT SHALL BE CLEAN, DRY AND FREE OF DEBRIS PRIOR TO ACCEPTANCE
4. ALL MECHANICAL JOINTS SHALL BE RESTRAINED WITH "MEGALUG" RETAINER GLANDS OR APPROVED EQUAL.
5. SERVICE LINE INTO VAULT SHALL BE MECHANICALLY RESTRAINED FROM MAINLINE THROUGH VAULT.
6. ALL PIPING TO BE BACKFILLED AS DESCRIBED & SHOWN IN STANDARD DETAIL 214.
7. INSTALL A MIN. OF 2 PIPE SUPPORTS IN VAULT (GRINNELL NO. 264 ELCEN NO. 59 OR APPROVED EQUAL) BY CITY DURING METER INSTALL.
8. ALL PIPING AND FITTINGS IN VAULT SHALL BE LEVEL
9. ONLY APPROVED RESILIENT WEDGE VALVES ARE ALLOWED.
10. PIPE BETWEEN THE TWO TEES SHALL BE ONE LEVEL CONTINUOUS PIECE OF PIPE.
11. ALL FITTINGS, VALVES AND PIPING THROUGH ENTIRE VAULT SHALL BE LEVEL AT COMPLETION OF INSTALLATION.
12. EXTERIOR VAULT WALLS SHALL BE BACKFILLED WITH 3/4" - 0" CRUSHED AGGREGATE TO WITHIN 1 FOOT OF FINISH GRADE, A MINIMUM WIDTH OF 2 FEET.

FILENAME: y:\inter-departmental\development engineering projects\public works standards\2.0 pws revision copy\details\cad - all\500_water\513c.dwg. Plotted 4/20/2026 10:52 AM, By: Anthony Dollowitch, ANSI FULL BLEED A (8.50 X 11.00 INCHES)



3" THROUGH 8" METER VAULT AND PIPING NOTES

PWS VERSION: JULY 2026

DRAWN	SRS
REV. DATE	JAN 2020
APPR.	
DETAIL NO.	513C

FILENAME: y:\inter-departmental\development engineering projects\public works standards\2.0 pws revision copy\details\cad - all\500_water\513d.dwg, Plotted 4/20/2026 10:52 AM, By: Anthony Dollowitch, ANSI FULL BLEED A (8.50 X 11.00 INCHES)

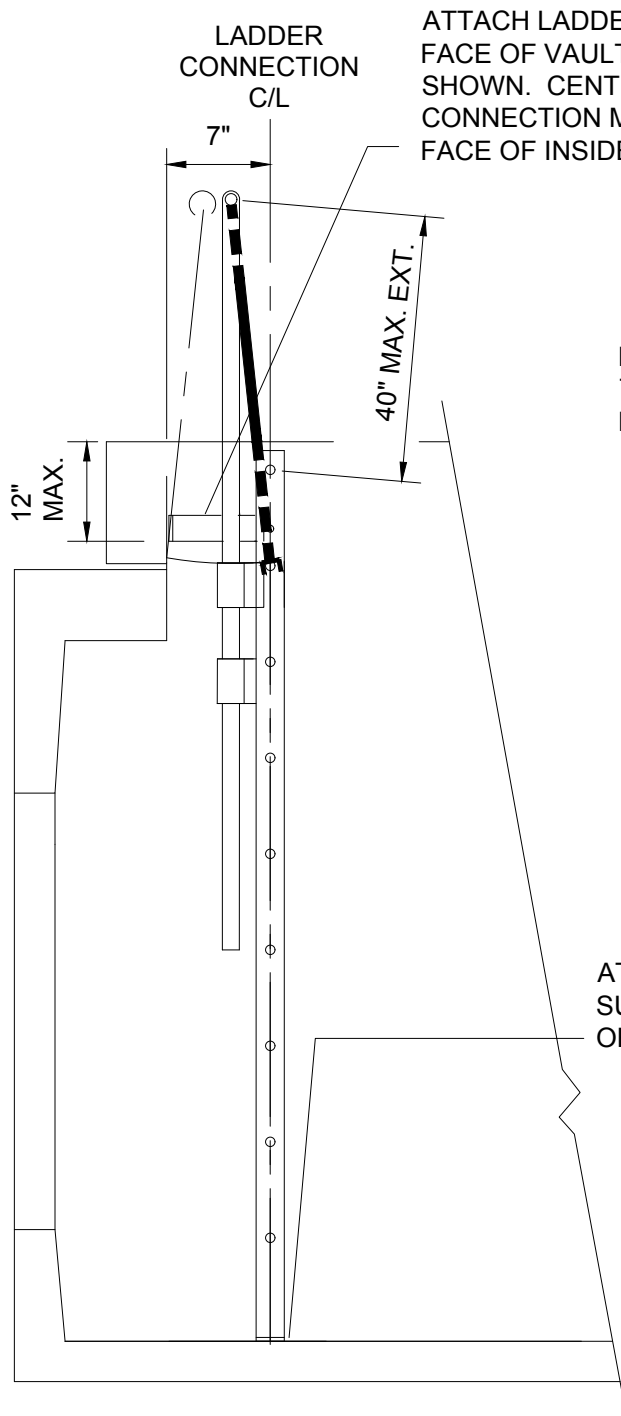

SIDE VIEW

ATTACH LADDER SUPPORT TO INSIDE FACE OF VAULT COVER OPENING AS SHOWN. CENTERLINE OF LADDER CONNECTION MUST BE SET 7" FROM FACE OF INSIDE SURFACE OF VAULT LID

PROVIDE 15" CLEARANCE TO ANY OBSTRUCTION ON EITHER SIDE OF LADDER

ATTACHED LADDER SUPPORT TO FLOOR OF VAULT

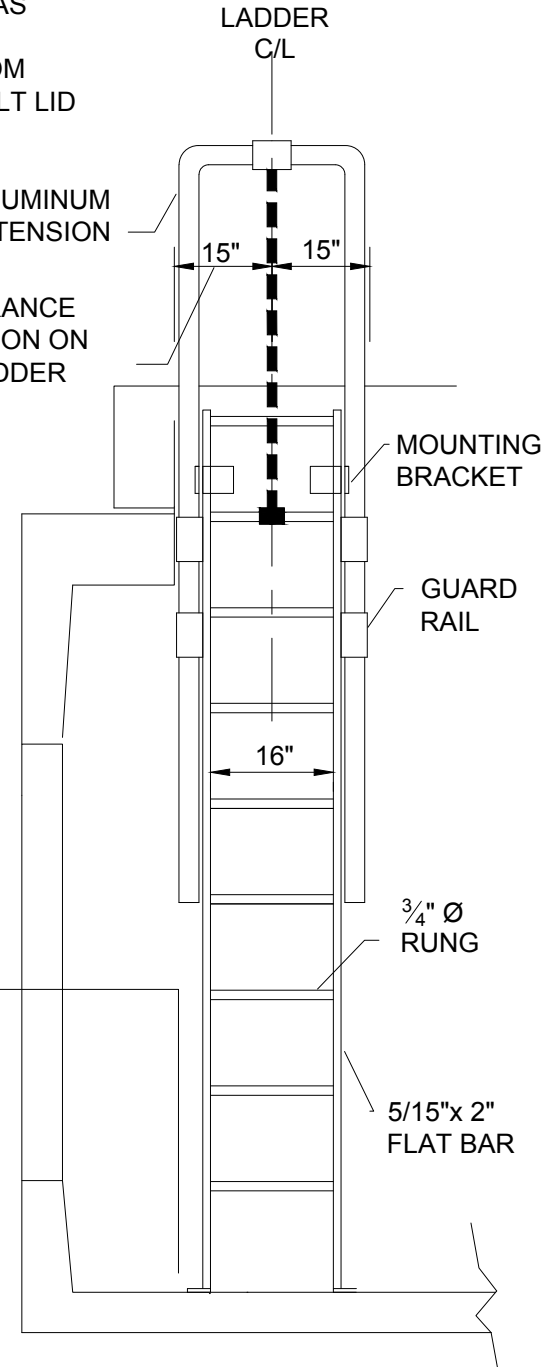

FRONT VIEW

NOTE:

GALV. LADDER WITH AN ALUMINUM EXTENSION BY UTILITY VAULT (OR APPROVED EQUAL)

CITY OF GRESHAM

LADDER WITH ALUMINUM EXTENSION

PWS VERSION: JULY 2026

DRAWN	SRS
REV. DATE	JAN 2019
APPR.	
DETAIL NO.	513D

FILENAME: y:\inter-departmental\development engineering projects\public works standards\2.0 pws revision copy\details\cad - all\500_water\514a.dwg, Plotted 4/20/2026 10:52 AM, By: Anthony Dolowitch, ANSI FULL BLEED A (8.50 X 11.00 INCHES)

BACK FLOW VAULT		
SIZE	VAULT WITH FDC*	VAULT W/O FDC*
3	676-WA	577-LA
4	676-WA	577-LA
6	676-WA	676-WA
8	687-WA	687-WA
10	5106-1-WA	5106-1-WA

* OR APPROVED EQUAL BY WATER ENG.

NOTES:

1. CONTRACTOR TO SEAL ALL OPENINGS IN VAULT WITH NON-SHRINK GROUT.
2. CONTRACTOR TO INSTALL CONCRETE BALLAST 3 CU YDS MIN. AROUND BASE OF VAULT WHERE FLOODING OR HIGH GROUND WATER EXIST.
3. STRADDLE BLOCK TO BE INSTALLED PER STANDARD DETAIL 509.
4. DETECTOR METER TO READ IN CUBIC FEET
5. FOR SPECIFICATIONS ON DOUBLE CHECK VALVE BACKFLOW ASSEMBLY SEE PWS 502.03.05
6. COAT ALL OUTSIDE CONC SURFACES OF VAULT W/ COMASEAL (OR APPROVED EQUAL)
7. WHEN A FIRE HYDRANT OR MULTIPLE BUILDINGS ARE ON SITE FDC AND PIV FACILITIES LOCATION WILL BE DETERMINED ON A CASE BY CASE BASIS.
8. SEE DETAIL 514B FOR SECTION A-A AND DETAIL 514C FOR SECTION B-B.

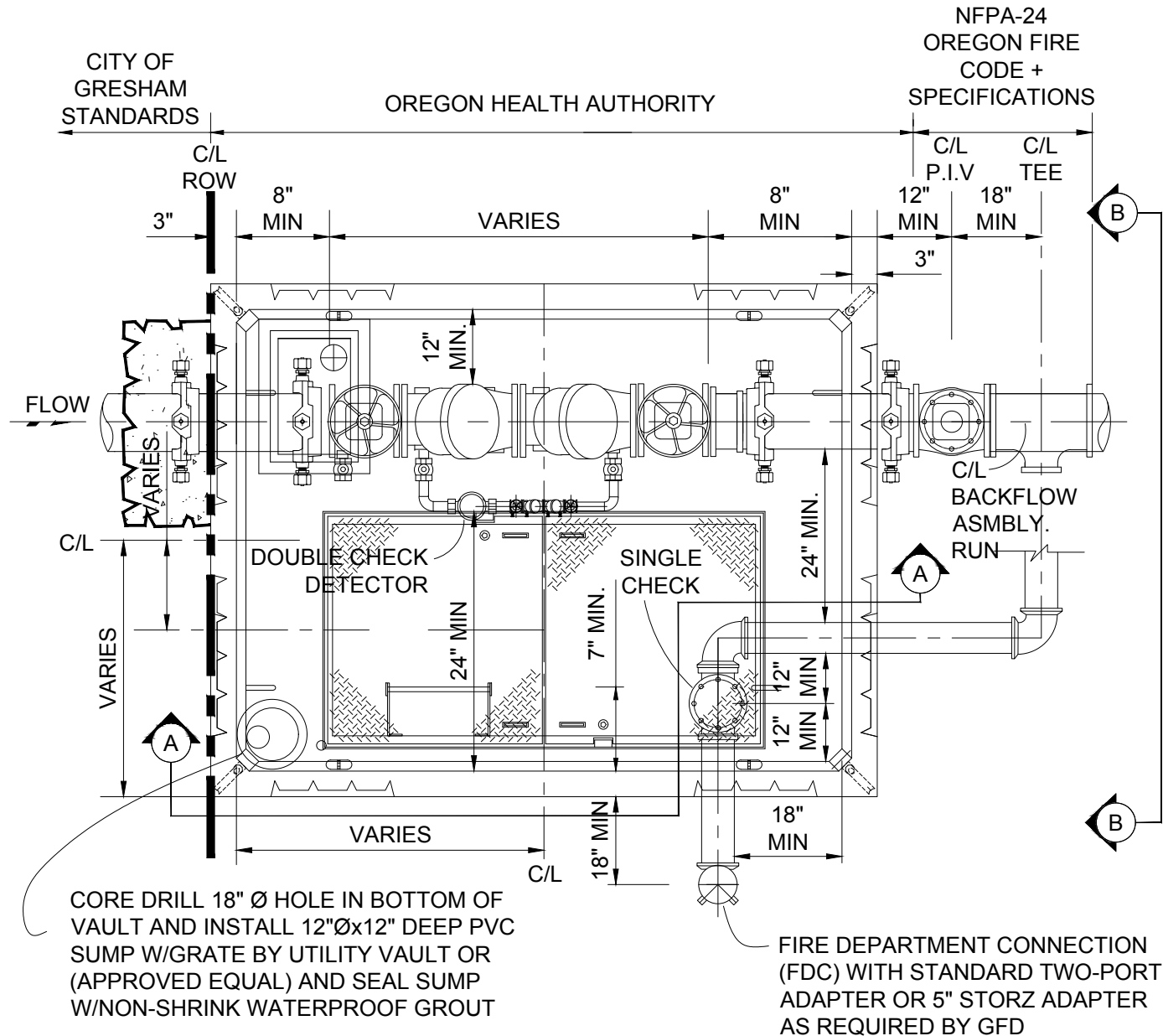

CORE DRILL 18" Ø HOLE IN BOTTOM OF VAULT AND INSTALL 12"Øx12" DEEP PVC SUMP W/GRATE BY UTILITY VAULT OR (APPROVED EQUAL) AND SEAL SUMP W/NON-SHRINK WATERPROOF GROUT

FIRE DEPARTMENT CONNECTION (FDC) WITH STANDARD TWO-PORT ADAPTER OR 5" STORZ ADAPTER AS REQUIRED BY GFD

PLAN



DOUBLE CHECK VALVE OR DOUBLE CHECK VALVE DETECTOR ASSEMBLY PLAN VIEW

PWS VERSION: JULY 2026

DRAWN	VC / JB
REV. DATE	APRIL 2026
APPR.	
DETAIL NO.	514A

NOTE:
 IF REQUIRED HEIGHT OF PROPOSED
 WATER BACK-FLOW ASSEMBLY
 IMPROVEMENTS IS GREATER THAN STD
 VAULT DEPTH FOR PROPOSED BACK
 FLOW ASSEMBLY SUBSTITUTE STD.
 VAULT TOP W/57-T-2-332P TOP AND
 ADD GRADE RINGS 57-T-3672 (8" OR 12")
 AS NEEDED TO MAINTAIN PROPER
 DEPTH.

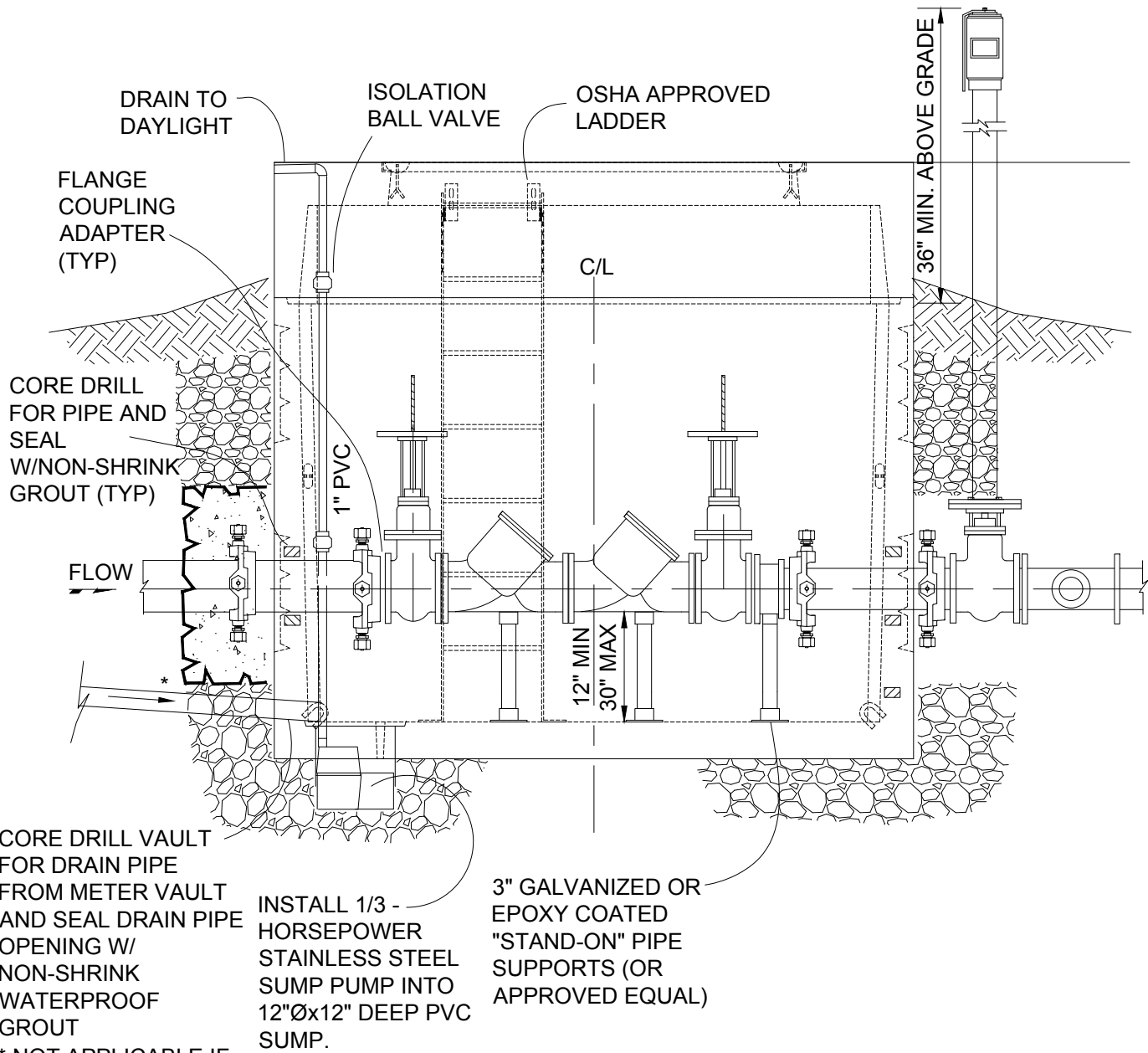

ELEVATION
 SECTION A-A

**DOUBLE CHECK VALVE OR DOUBLE
 CHECK VALVE DETECTOR ASSEMBLY
 ELEVATION VIEW**

**CITY OF
 GRESHAM**

PWS VERSION: JULY 2026

DRAWN	RWL
REV. DATE	JAN 2024
APPR.	
DETAIL NO.	514B

FILENAME: y:\inter-departmental\development_engineering_projects\public_works_standards\2.0_pws_revision_copy\details\cad - all\500_water\514c.dwg, Plotted 4/20/2026 10:52 AM, By: Anthony Dolowitch, ANSI FULL BLEED A (8.50 X 11.00 INCHES)

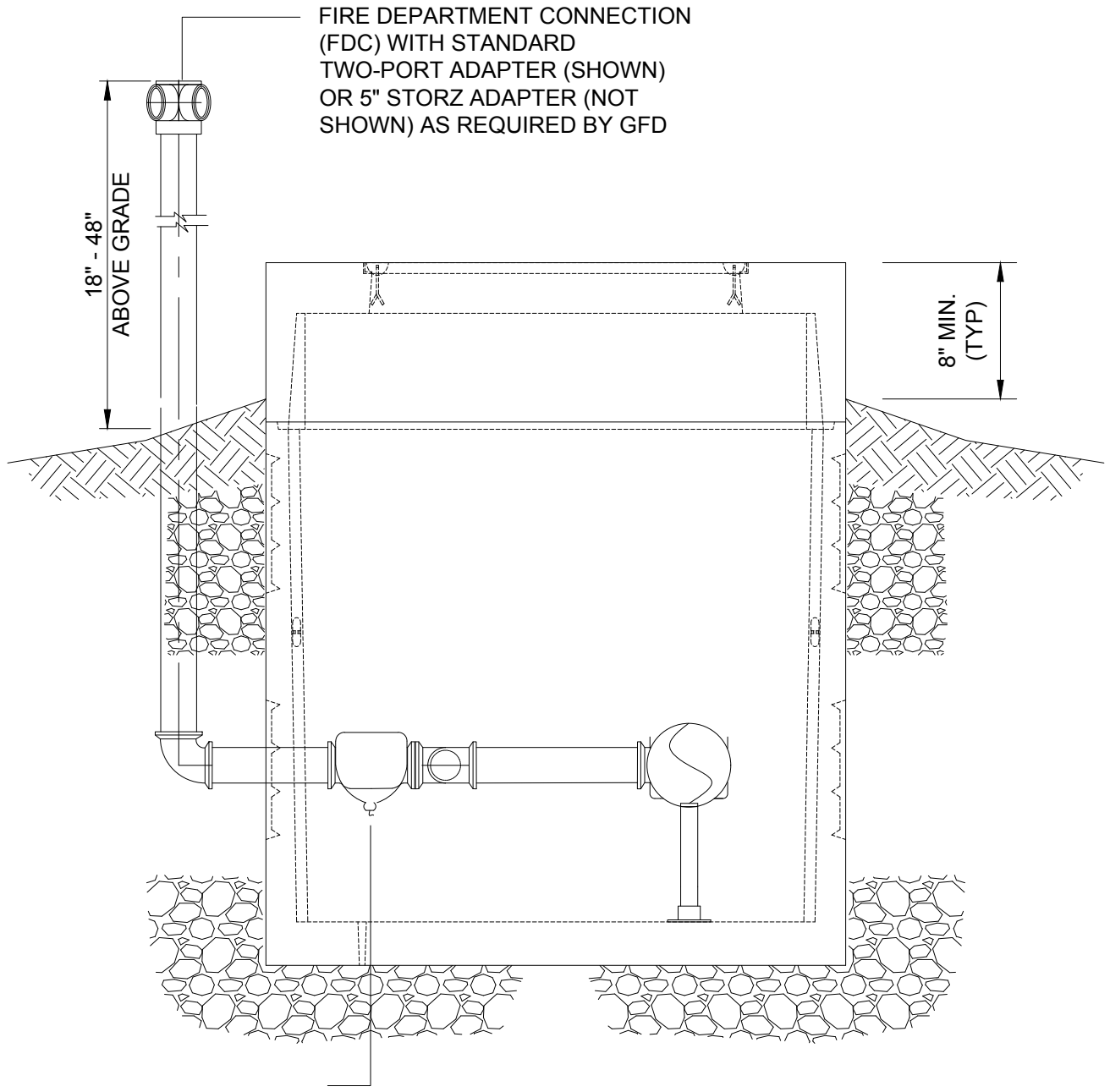

AUTOMATIC BALL
DRIP BELOW SINGLE
CHECK

END ELEVATION
SECTION B-B

**CITY OF
GRESHAM**

**TYPICAL FIRE DEPARTMENT CONNECTION
INSTALLATION**

PWS VERSION: JULY 2026

DRAWN	RWL
REV. DATE	JAN 2019
APPR.	
DETAIL NO.	514C

FILENAME: y:\inter-departmental\development_engineering_projects\public_works_standards\20_pws_revision_copy\details\cad - all\500_water\514d.dwg, Plotted 4/20/2026 10:52 AM, By: Anthony Dollowitch, ANSI FULL BLEED A (8.50 X 11.00 INCHES)

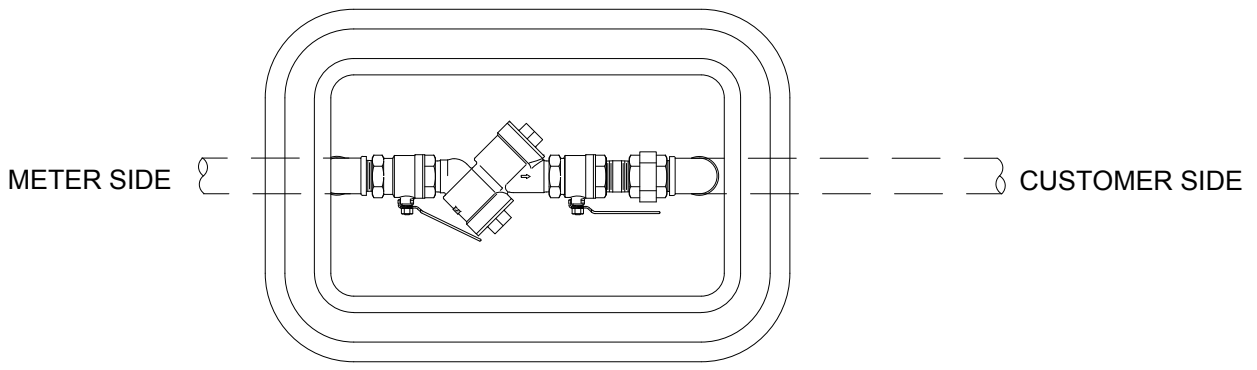

PLAN

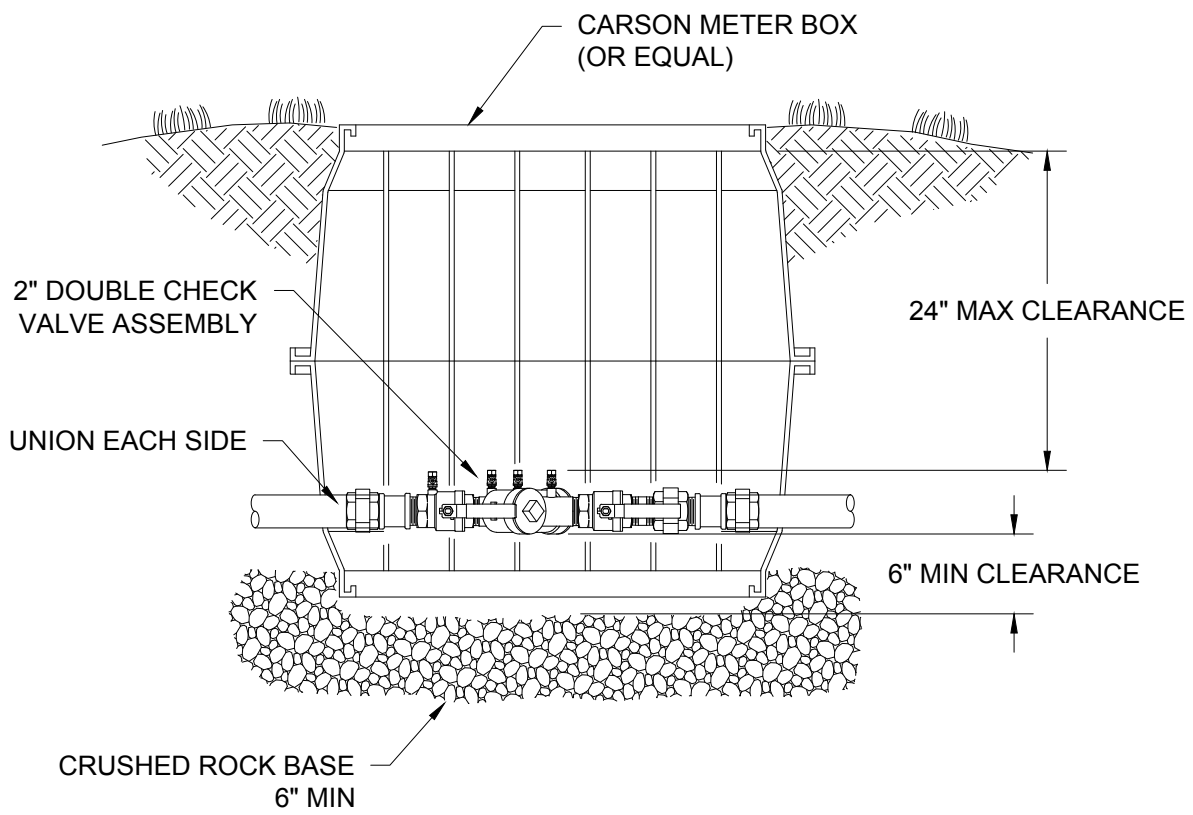

ELEVATION

NOTE:
 INSTALLATION SHOWN IS ONLY A SUGGESTION. THE DISTANCE FROM BOTTOM OF ASSEMBLY TO FINISH GRADE, FREEZE PROTECTION, AND CLEARANCE FOR TESTING & REPAIR ARE THE MAJOR CONSIDERATIONS FOR INSTALLATION. PLUGS TO BE INSTALLED IN TEST COCKS OF BELOW GROUND INSTALLATIONS (NO DISSIMILAR METALS).

IF FREEZE PROTECTION IS PROVIDED, THE 24" CLEARANCE MAY BE REDUCED TO 18".

CITY OF GRESHAM

3/4" THROUGH 2" DOUBLE CHECK INSTALLATION

PWS VERSION: JULY 2026

DRAWN	JIA
REV. DATE	JAN 2019
APPR.	
DETAIL NO.	514D

FILENAME: y:\inter-departmental\development engineering projects\public works standards\2.0 pws revision copy\details\cad - all\500_water\514e.dwg, Plotted 4/20/2026 10:52 AM, By: Anthony Dollowitch, ANSI FULL BLEED A (8.50 X 11.00 INCHES)

TOP VIEW

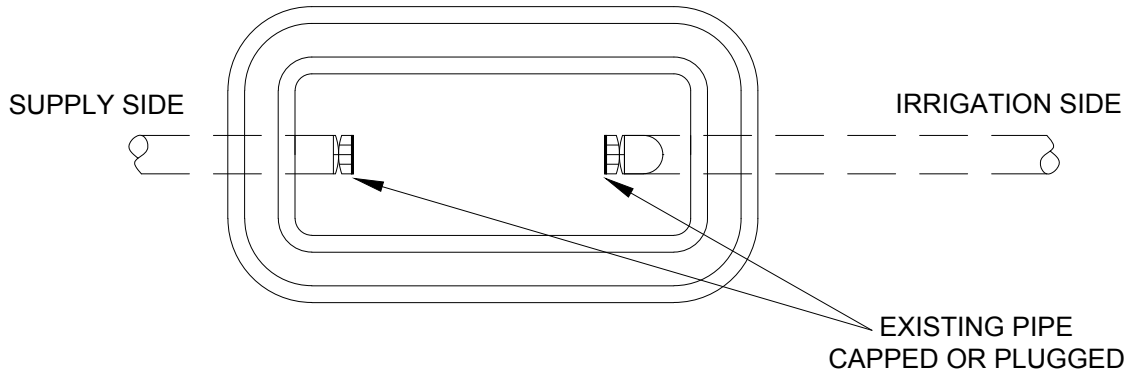

SIDE VIEW

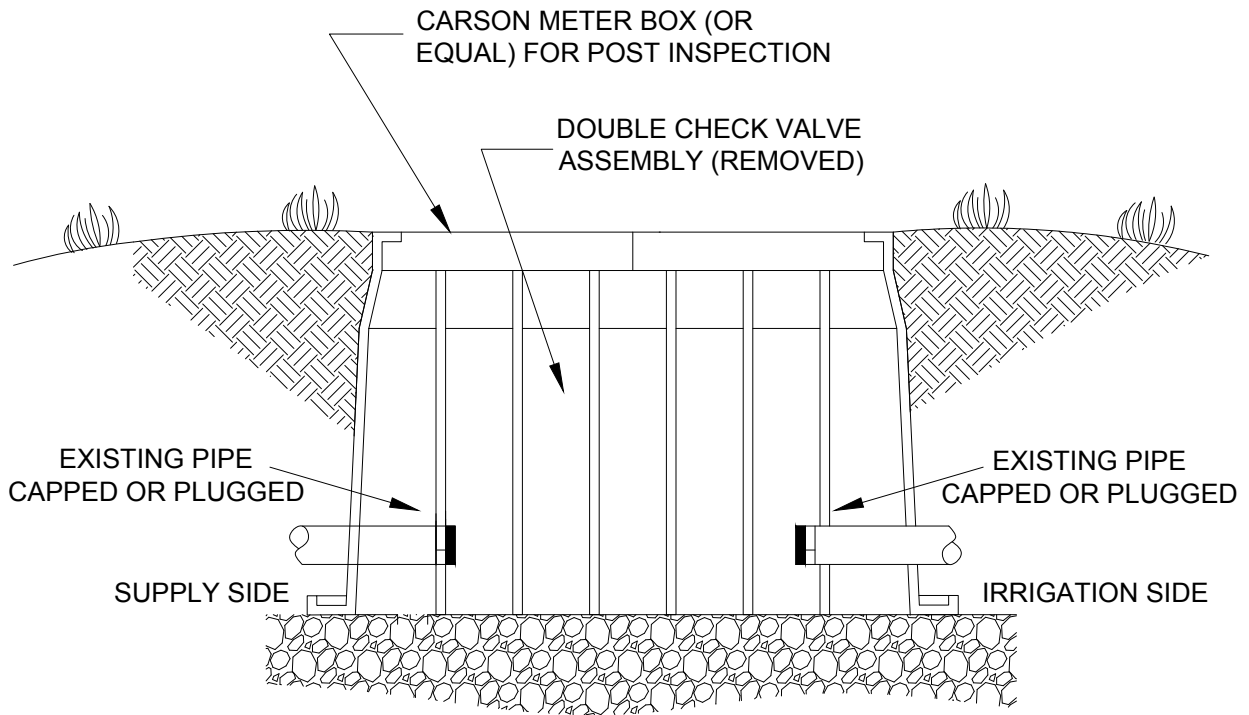

NOTE:
 CALL GRESHAM WATER DIVISION TO SCHEDULE INSPECTION OF ABANDONMENT
 503-618-2626

**CITY OF
 GRESHAM**

ABANDONMENT OF LAWN IRRIGATION BACKFLOW ASSEMBLY

PWS VERSION: JULY 2026

DRAWN	JIA
REV. DATE	JAN 2019
APPR.	
DETAIL NO.	514E

FILENAME: y:\inter-departmental\development engineering projects\public works standards\2.0 pws revision copy\details\cad - all\500_water\514f.dwg. Plotted 4/20/2026 10:52 AM, By: Anthony Dollowitch, ANSI FULL BLEED A (8.50 X 11.00 INCHES)

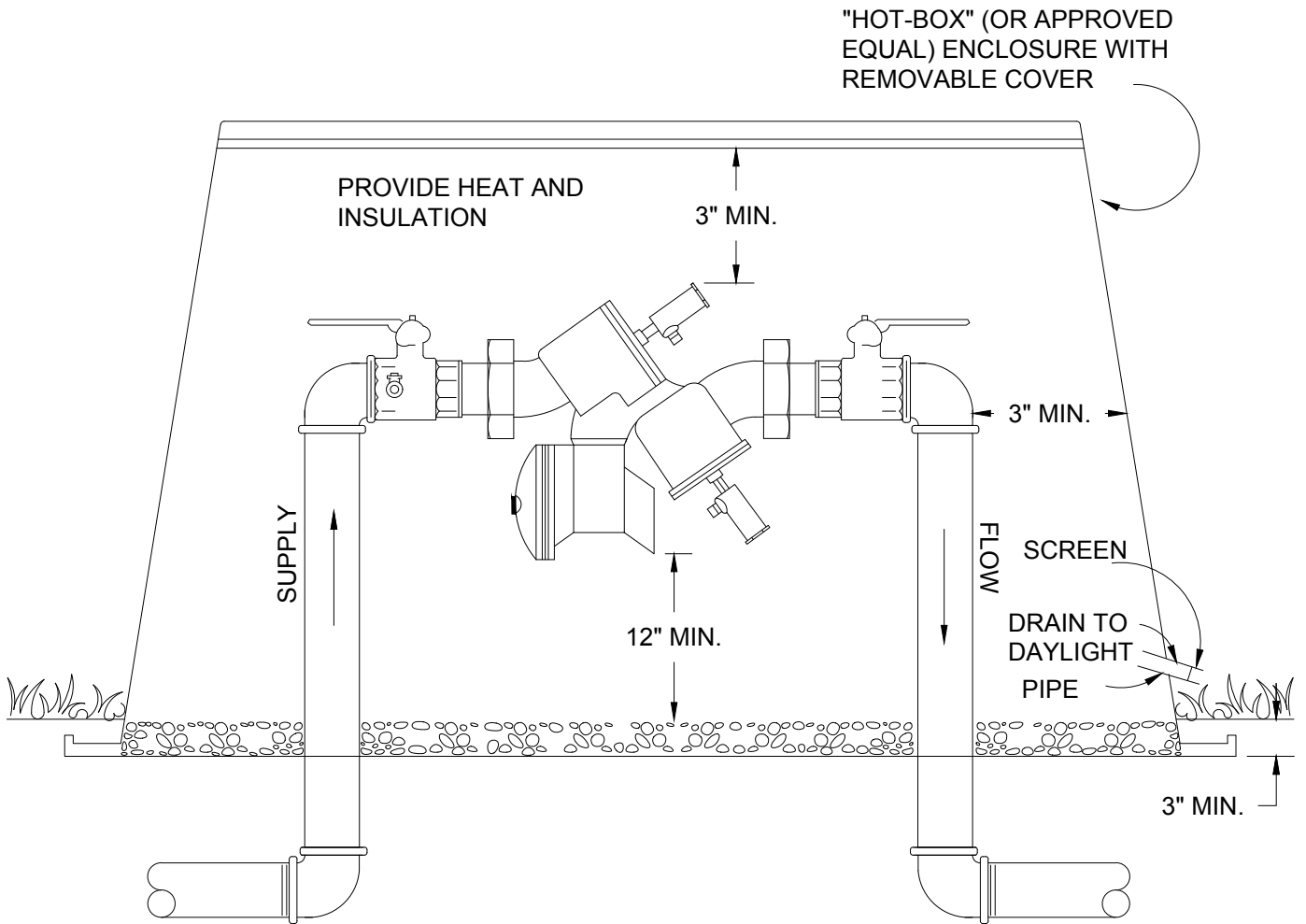

CITY OF
GRESHAM

REDUCED PRESSURE PRINCIPLE SMALL
ASSEMBLY 2 1/2" AND SMALLER

PWS VERSION: JULY 2026

DRAWN WJA

REV. DATE JAN 2019

APPR.

DETAIL NO. 514F

FILENAME: y:\inter-departmental\development engineering projects\public works standards\2.0 pws revision copy\details\cad - all\500_water\514g.dwg, Plotted 4/20/2026 10:52 AM, By: Anthony Dollowitch, ANSI FULL BLEED A (8.50 X 11.00 INCHES)

OREGON HEALTH AUTHORITY
APPROVED ASSEMBLY
AND INSTALLATION

CITY OF
GRESHAM
STANDARDS

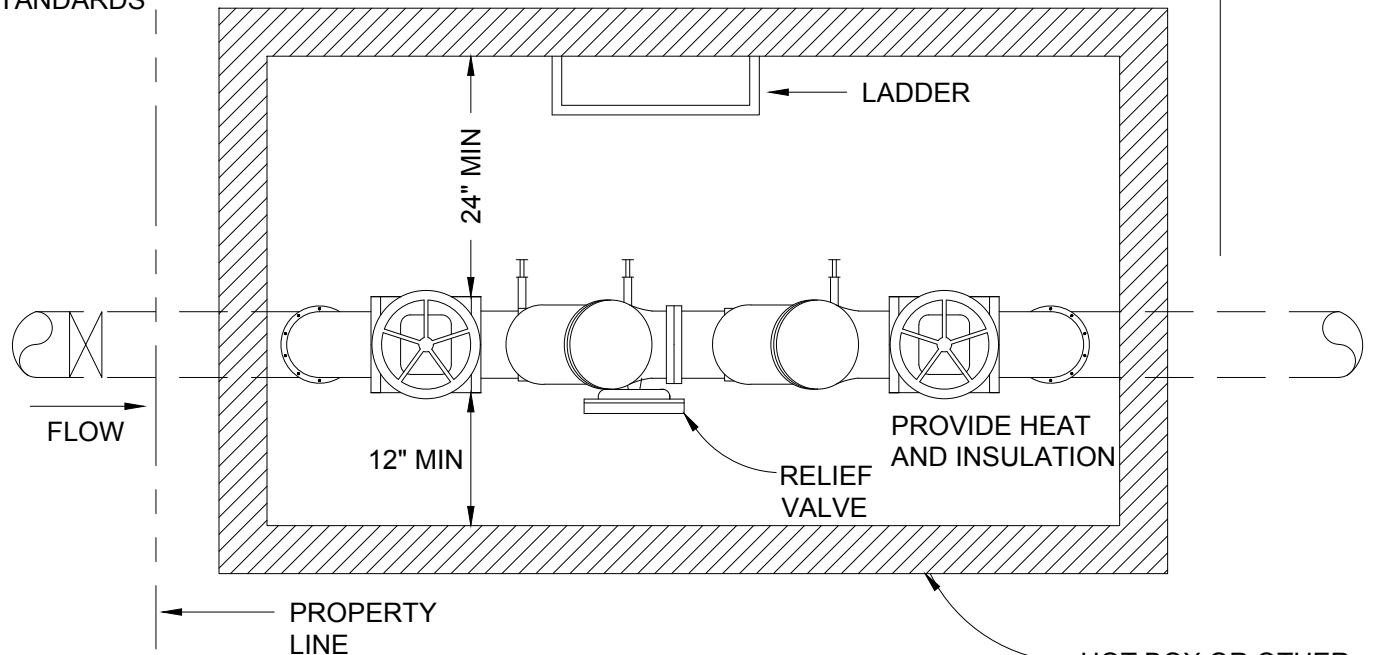

TOP VIEW

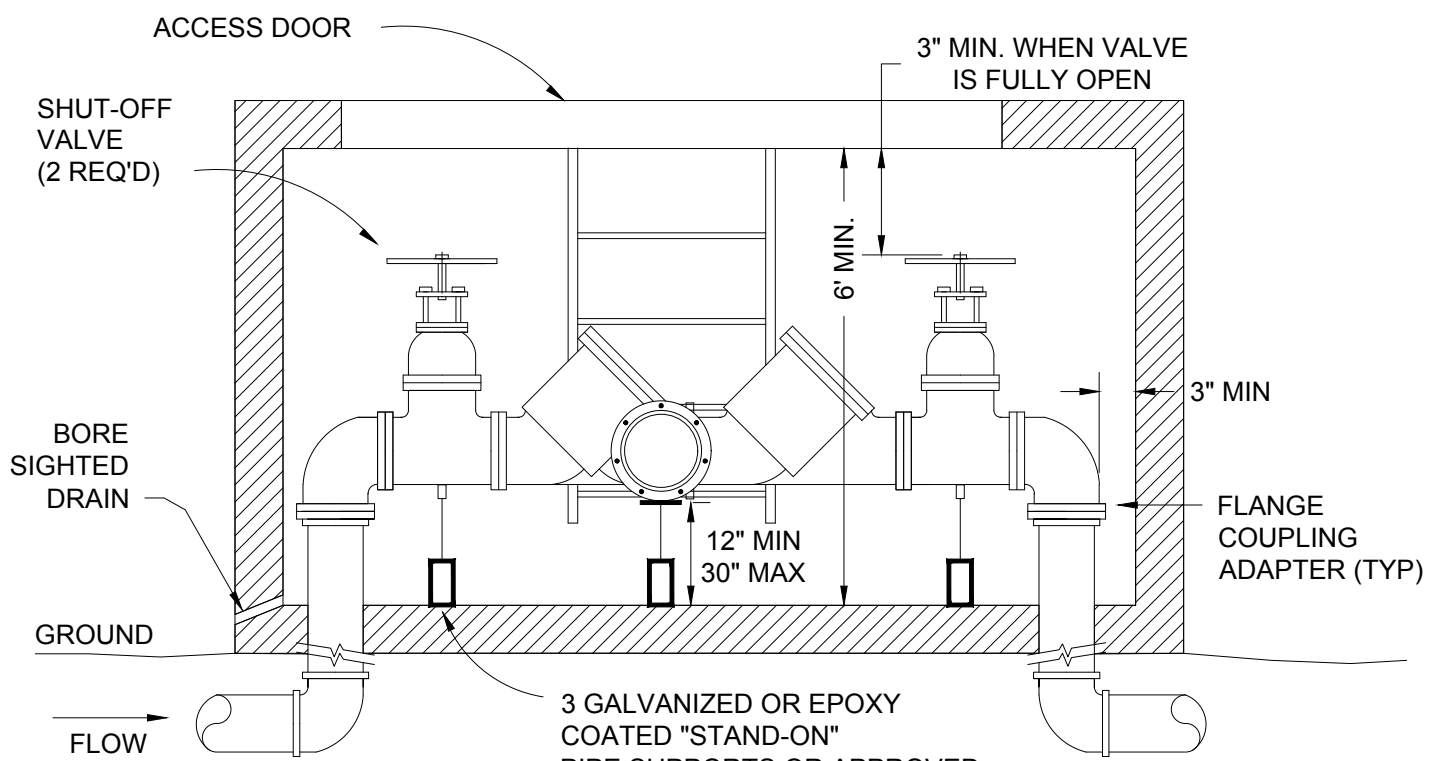

SIDE VIEW

NOTE:
FOR MORE DETAIL SEE PWS
502.03.05B

**CITY OF
GRESHAM**

**REDUCED PRESSURE PRINCIPLE ASSEMBLY
3" AND LARGER**

PWS VERSION: JULY 2026

DRAWN	WJA
REV. DATE	JAN 2019
APPR.	
DETAIL NO.	514G

SUMP PUMP DRAIN LINE TO DAYLIGHT

ADD EXTRA GRADE RING FOR THE BACK FLOW VAULT AS NEEDED TO MAINTAIN A DEEPER DEPTH TO ACCOMMODATE DRAINAGE FROM METER VAULT.

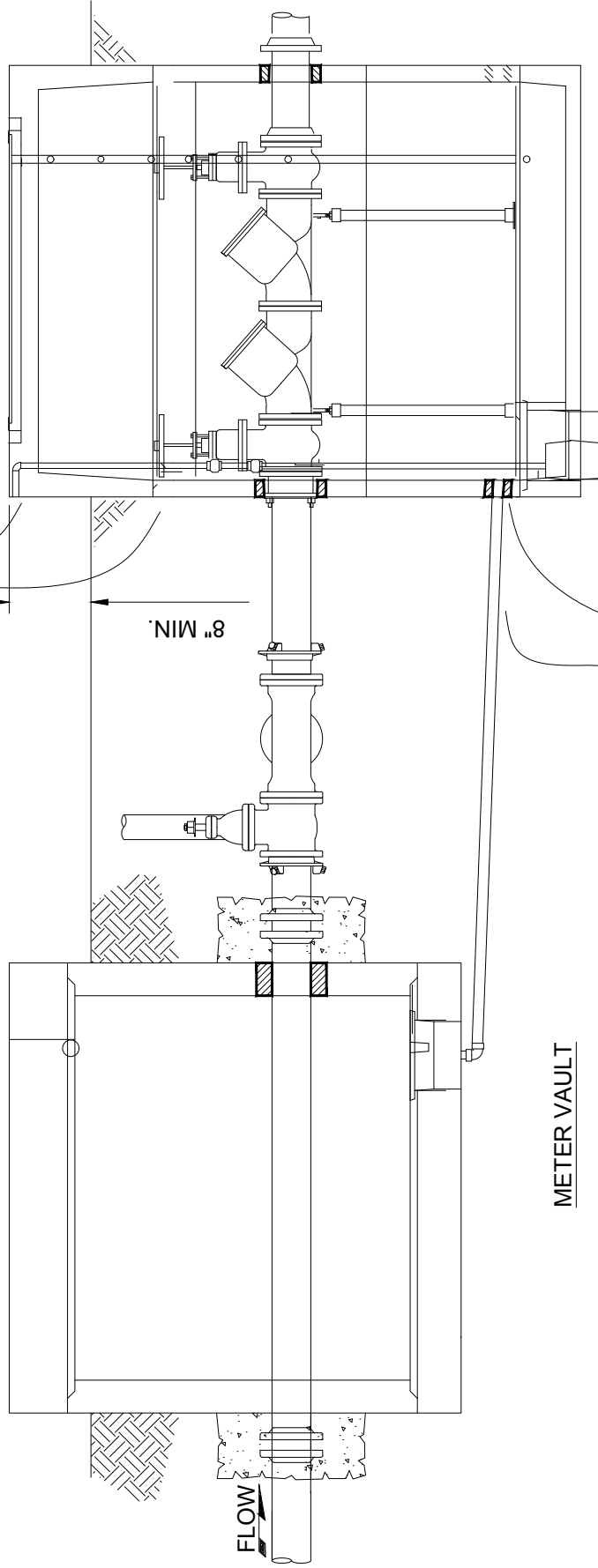

BACKFLOW VAULT

CORE DRILL HOLES IN BACKFLOW VAULTS TO ACCOMMODATE PVC DRAIN PIPE FROM METER VAULT. SEE DETAIL 514A FOR DRAINAGE REQUIREMENTS OF BACKFLOW VAULT

MAINTAIN MIN. 1% SLOPE OF PVC PIPE FROM THE SUMP OF METER VAULT TO THE BACKFLOW VAULT AS SHOWN

METER VAULT

DRAWN	RWL
REV. DATE	JAN 2019
APPR.	
DETAIL NO.	514H

FILENAME: y:\inter-departmental\development engineering projects\public works standards\2.0 pws revision copy\details\cad - all\500_water\515a.dwg, Plotted 4/20/2026 10:52 AM, By: Anthony Dollowitch, ANSI FULL BLEED A (8.50 X 11.00 INCHES)

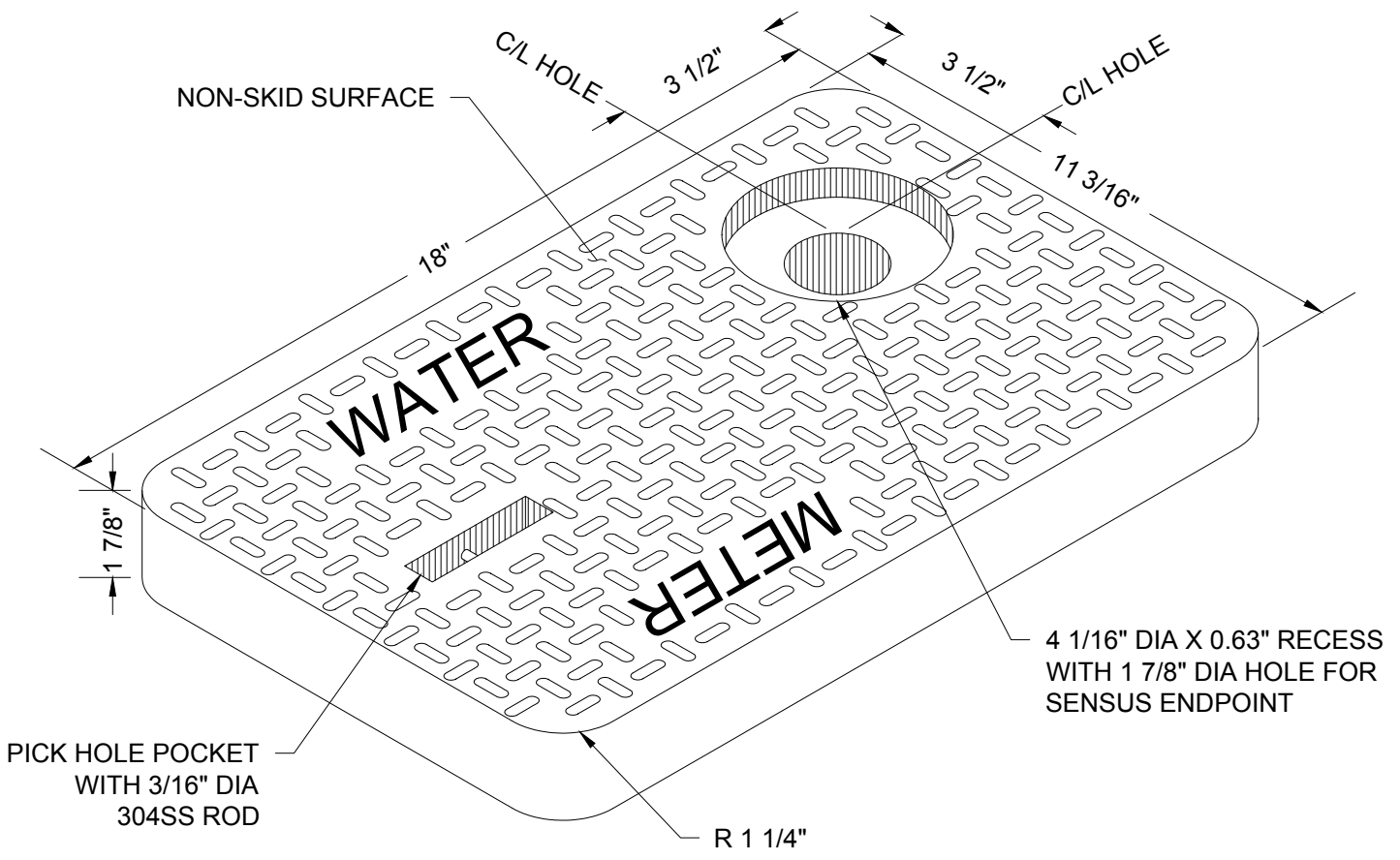

NOTES:

1. DFW PLASTICS, INC. METER BOX COVER, AS SHOWN FOR STANDARD WATER METER BOX LOCATIONS, PART #DFW486C-4MPT 63D NHK-LID (OR APPROVED EQUAL).

CITY OF GRESHAM

3/4" - 1" METER COVER

PWS VERSION: JULY 2026

DRAWN	KRB
REV. DATE	AUG 2024
APPR.	
DETAIL NO.	515A

FILENAME: y:\inter-departmental\development engineering projects\public works standards\2.0 pws revision copy\details\cad - all\500_water\515b.dwg, Plotted 4/20/2026 10:52 AM, By: Anthony Dollowitch, ANSI FULL BLEED A (8.50 X 11.00 INCHES)

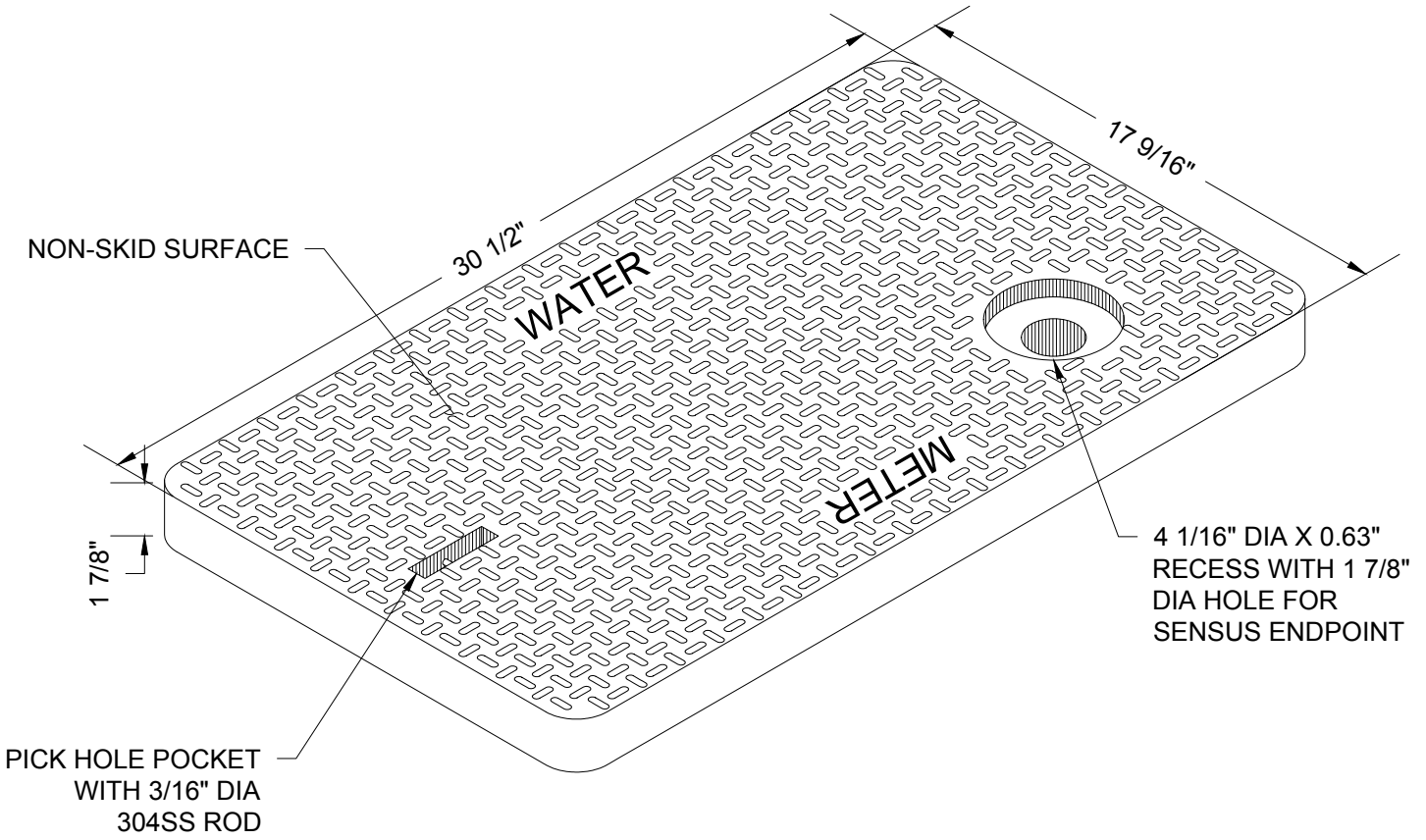

NOTES:

1. DFW PLASTICS, INC. METER BOX COVER, PART #DFW1730C-4MPT 63D NHK-LID (OR APPROVED EQUAL).
2. METER BOX COVERS SHALL NOT BE LOCATED IN VEHICULAR TRAFFIC AREAS.

CITY OF GRESHAM

1 1/2" - 2" METER COVER

PWS VERSION: JULY 2026

DRAWN	KRB
REV. DATE	AUG 2024
APPR.	
DETAIL NO.	515B

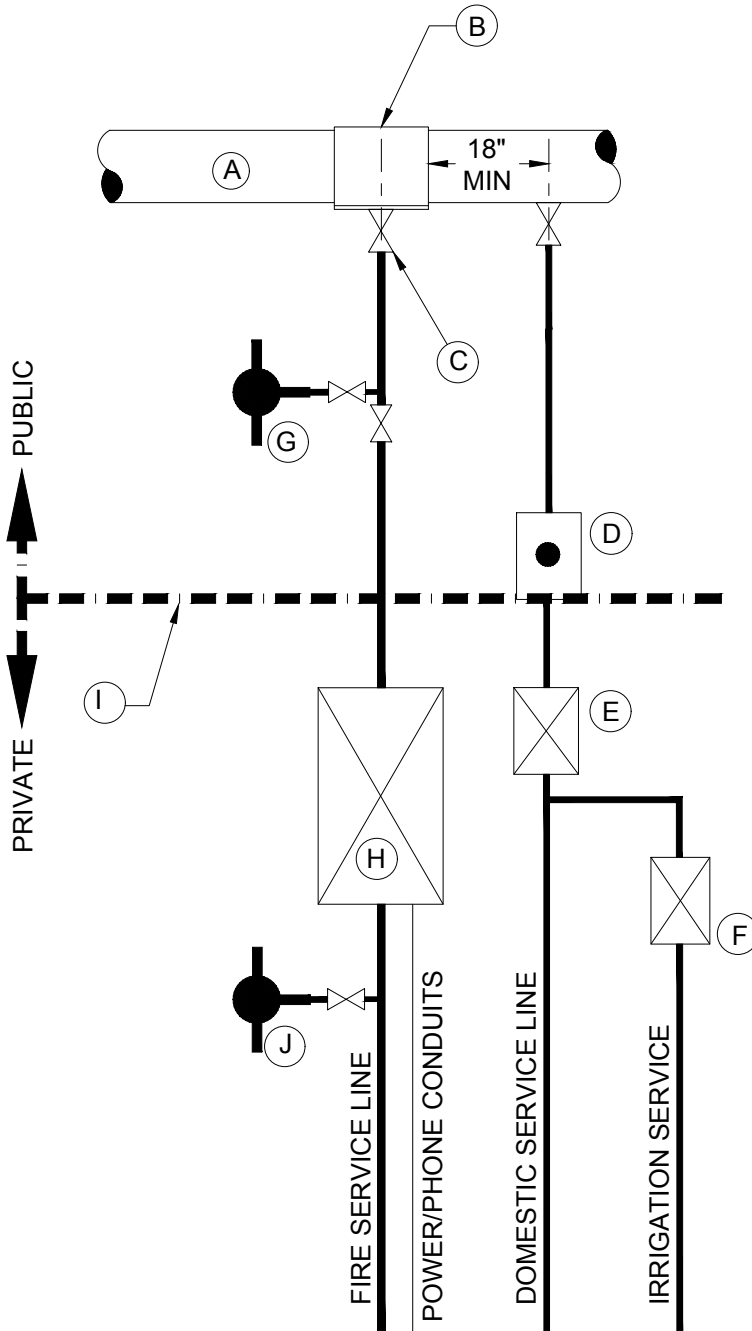

MATERIALS:

- (A) EXISTING WATER MAIN.
- (B) SERVICE CONNECTION WET TAP BY CITY APPROVED CONTRACTOR.
- (C) VALVE (TYPICAL).
- (D) DOMESTIC WATER SERVICE METER.
- (E) DOMESTIC SERVICE BACKFLOW PREVENTION ASSEMBLY.
- (F) IRRIGATION BACKFLOW PREVENTION ASSEMBLY.
- (G) PUBLIC FIRE HYDRANT (IF REQUIRED).
- (H) FIRE SERVICE BACKFLOW PREVENTION ASSEMBLY.
- (I) RIGHT-OF-WAY LINE.
- (J) PRIVATE HYDRANT OR FIRE DEPT CONNECTION (FDC) - REFER TO NOTE 3.

NOTES:

1. THE IRRIGATION SYSTEM SHALL BE CONNECTED DOWNSTREAM OF THE DOMESTIC SERVICE BACKFLOW PREVENTION ASSEMBLY (OPTION A) OR SHALL HAVE ITS OWN DEDICATED METER (OPT. W/ ADD. SDC) AND BACKFLOW ASSEMBLY (OPTION B).
2. DOMESTIC AND FIRE SERVICE LINES 4" AND LARGER SHALL BE DUCTILE IRON FOR A DISTANCE OF 5' MINIMUM DOWNSTREAM OF THE BACKFLOW VAULT.
3. PRIVATE FDC OR HYDRANT MUST BE LOCATED ON CUSTOMER SIDE OF BACKFLOW ASSEMBLY.

CITY OF GRESHAM

TYPICAL COMMERCIAL/INDUSTRIAL SERVICE LAYOUT

PWS VERSION: JULY 2026

DRAWN	JIA
REV. DATE	JAN 2022
APPR.	
DETAIL NO.	516

FILENAME: y:\inter-departmental\development engineering projects\public works standards\2.0 pws revision copy\details\cad - all\500_water\517.dwg. Plotted 4/20/2026 10:52 AM. By: Anthony Dollowitch, ANSI FULL BLEED A (8.50 X 11.00 INCHES)

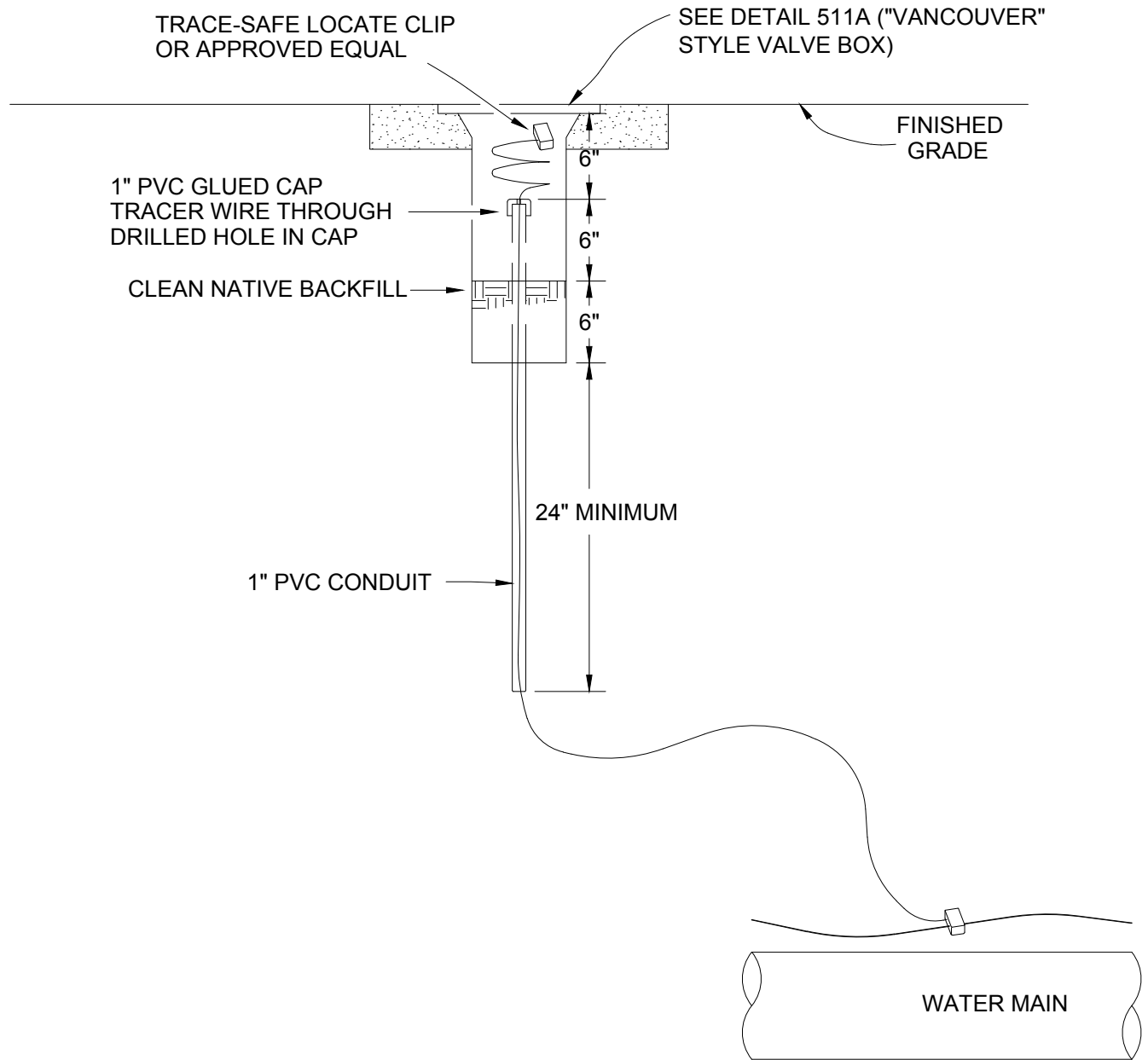

NOTES:

1. VALVE BOXES SHALL BE IN A VERTICAL POSITION.
2. VALVE BOX TOP SHALL BE ADJUSTED TO MEET FINISH GRADE.
3. PROVIDE 2' EXCESS TRACER WIRE BETWEEN CONDUIT CAP AND LOCATE CLIP.

**CITY OF
GRESHAM**

LOCATE WIRE BOX

PWS VERSION: JULY 2026

DRAWN **WJA**

REV. DATE **JAN 2019**

APPR.

DETAIL NO. **517**