

- NOTES:**
1. IF EIGHT FOOT GENERAL UTILITY EASEMENT IS PRESENT ALONG PROPERTY FRONTAGE, PLACEMENT SHALL BE AT BACK OF SIDEWALK WITHIN UTILITY EASEMENT.
 2. ON STREETS LESS THAN 30' IN WIDTH, WATERLINE LOCATION SHALL MAINTAIN 5' SPACING FROM FACE OF CURB. THERE SHALL BE 5' MINIMUM SPACING CENTER TO CENTER BETWEEN THE WATERLINE AND STORMWATER LINE AND THE STORMWATER LINE SHALL BE 3' FROM THE CENTERLINE.
 3. WHERE NO PLANTER STRIP EXISTS, FIRE HYDRANTS ARE TO BE LOCATED IN LINE WITH STREETLIGHTS & STREET TREES, OR AT BACK OF WALK. IF OUTSIDE THE R.O.W., LOCATE IN A 6' X 6' EASEMENT.
 4. 3" DIA. CONDUIT REQUIRED ON ALL ARTERIAL STREETS TO SERVE SIGNAL SYSTEM.
 5. OVERHEAD UTILITIES SHALL PROVIDE FOR A MINIMUM OF 17.5' CLEARANCE FROM GROUND SURFACE FOR ALL OVER-DIMENSIONAL VEHICLE ROUTES AND A MINIMUM OF 16' CLEARANCE IN ALL OTHER AREAS WITHIN THE RIGHT-OF-WAY.

JOINT TRENCH DETAIL

NTS

DRAWN	CM
REV. DATE	JAN 2024
APPR.	
DETAIL NO.	601

FILENAME: y:\inter-departmental\development engineering projects\public works standards\20 pws revision copy\details\cad - all\600_transportation\602a.dwg, Plotted 4/20/2026 11:16 AM, By: Anthony Dollowitch, ANSI FULL BLEED A (8.50 X 11.00 INCHES)

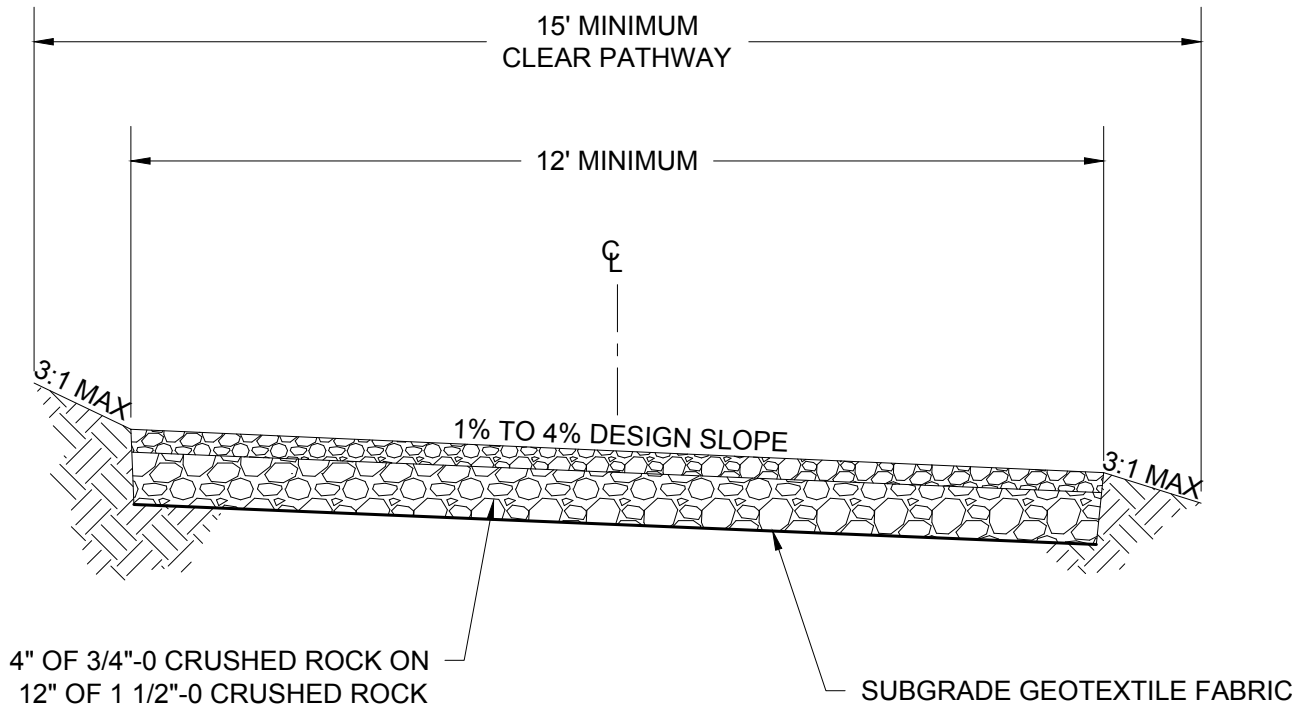

NOTES:

1. ALLOWED FOR PUBLIC UTILITY ACCESS ONLY.
2. A BRANCH TURNAROUND, PER DETAIL 616, SHALL BE PROVIDED ON ALL DEAD-END ACCESS ROADS. THE BRANCH TURNAROUND SHALL HAVE A MINIMUM TURNING RADIUS OF 50 FEET.
3. SUBGRADE AND AGGREGATE SHALL BE COMPACTED TO 95% RELATIVE DENSITY PER ASTM D1557.
4. ACCESS ROAD GRADES ARE NOT TO EXCEED 10%.
5. BOLLARDS, PER DETAIL 627, ARE REQUIRED AT ALL ENTRANCES TO ACCESS ROADS.

CITY OF GRESHAM

GRAVEL PUBLIC ACCESS ROAD

PWS VERSION: JULY 2026

DRAWN	AAD
REV. DATE	OCT 2025
APPR.	
DETAIL NO.	602A

FILENAME: y:\inter-departmental\development engineering projects\public works standards\2.0 pws revision copy\details\cad - all\600_transportation\602b.dwg, Plotted 4/20/2026 11:17 AM, By: Anthony Dollowitch, ANSI FULL BLEED A (8.50 X 11.00 INCHES)

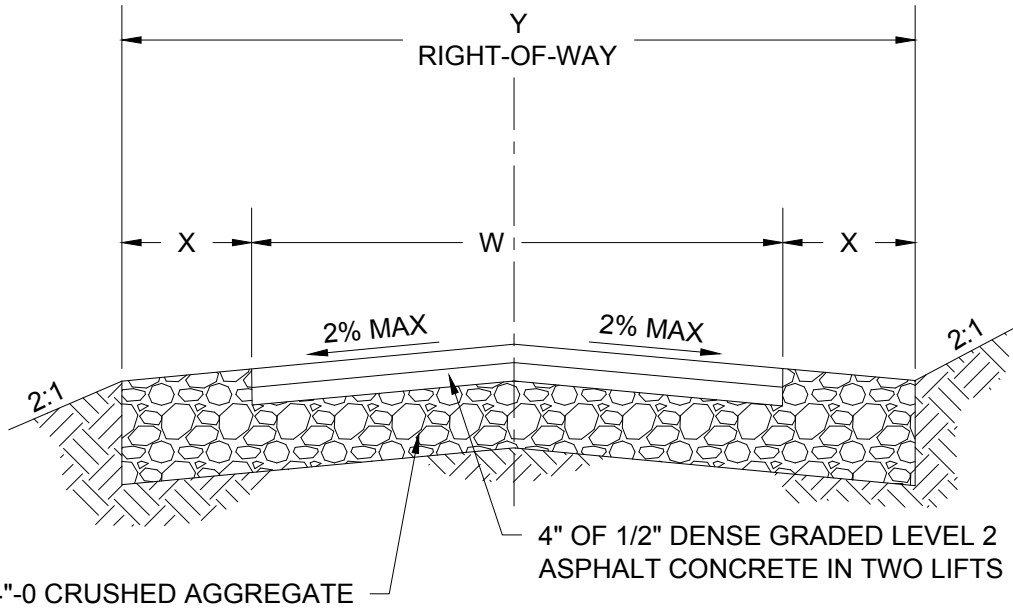

ACCESS DESCRIPTION	W	X	Y
ONE ACCESS POINT GREATER THAN 150 FEET IN LENGTH	20'	2.5'	25'
DRIVE THROUGH ACCESS OR ONE ACCESS POINT WITH A MAXIMUM OF 150 FEET IN LENGTH	12'	1.5'	15'

NOTES:

1. REQUIRED FOR PUBLIC ACCESS, EXCEPT WHERE UNPAVED ACCESS IS PERMITTED PER DETAIL 602A.
2. ASPHALT CONCRETE SHALL BE COMPACTED TO 91% OF RICE DENSITY.
3. SUBGRADE AND BASEROCK SHALL BE COMPACTED TO 95% RELATIVE DENSITY PER ASTM D1557.
4. A SIDEWALK AND PLANTER STRIP ARE NOT REQUIRED.
5. ENGINEER OF RECORD IS RESPONSIBLE FOR PROVIDING ADEQUATE DRAINAGE/CONVEYANCE IN LIEU OF PROVIDING CURBS.
6. ACCESS ROAD GRADES ARE NOT TO EXCEED 10%.
7. BOLLARDS ARE REQUIRED AT ALL ENTRANCES TO ACCESS ROADS. SEE DETAIL 627.

CITY OF GRESHAM

PAVED PUBLIC ACCESS ROAD

PWS VERSION: JULY 2026

DRAWN	AAD
REV. DATE	OCT 2025
APPR.	
DETAIL NO.	602B

FILENAME: y:\inter-departmental\development engineering projects\public works standards\2.0 pws revision copy\details\cad - all\600_transportation\603.dwg, Plotted 4/20/2026 11:17 AM, By: Anthony Dollowitch, ANSI FULL BLEED A (8.50 X 11.00 INCHES)

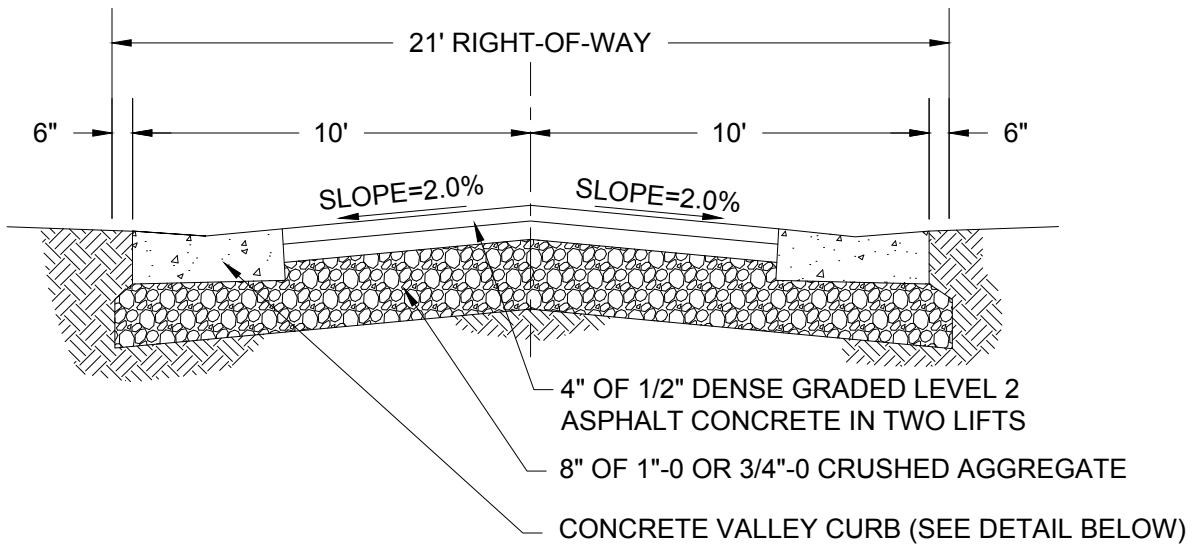

VALLEY CURB DETAIL

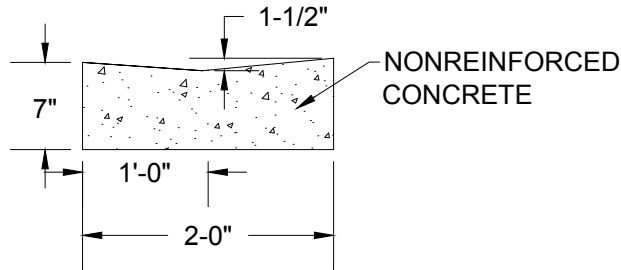

NOTES:

1. ASPHALT CONCRETE SHALL BE COMPACTED TO 91% OF RICE DENSITY.
2. SUBGRADE AND BASEROCK SHALL BE COMPACTED TO 95% RELATIVE DENSITY PER ASTM D1557.
3. PCC CURB SHALL BE 4,000 PSI AT 28 DAYS.
4. "NO PARKING" SHALL BE POSTED THE ENTIRE LENGTH OF ALLEY IN RESIDENTIAL AND COMMERCIAL/INDUSTRIAL DISTRICTS.
5. FIRE HYDRANTS, WHEN REQUIRED, ARE TO BE LOCATED OUTSIDE THE ROW IN A 6' BY 6' EASEMENT.

NTS



ALLEY STREET SECTION

PWS VERSION: JULY 2026

DRAWN	AAD
REV. DATE	JULY 2025
APPR.	
DETAIL NO.	603

FILENAME: y:\inter-departmental\development engineering projects\public works standards\2.0 pws revision copy\details\cad - all\600_transportation\604.dwg, Plotted 4/20/2026 11:17 AM, By: Anthony Dollowitch, ANSI FULL BLEED A (8.50 X 11.00 INCHES)

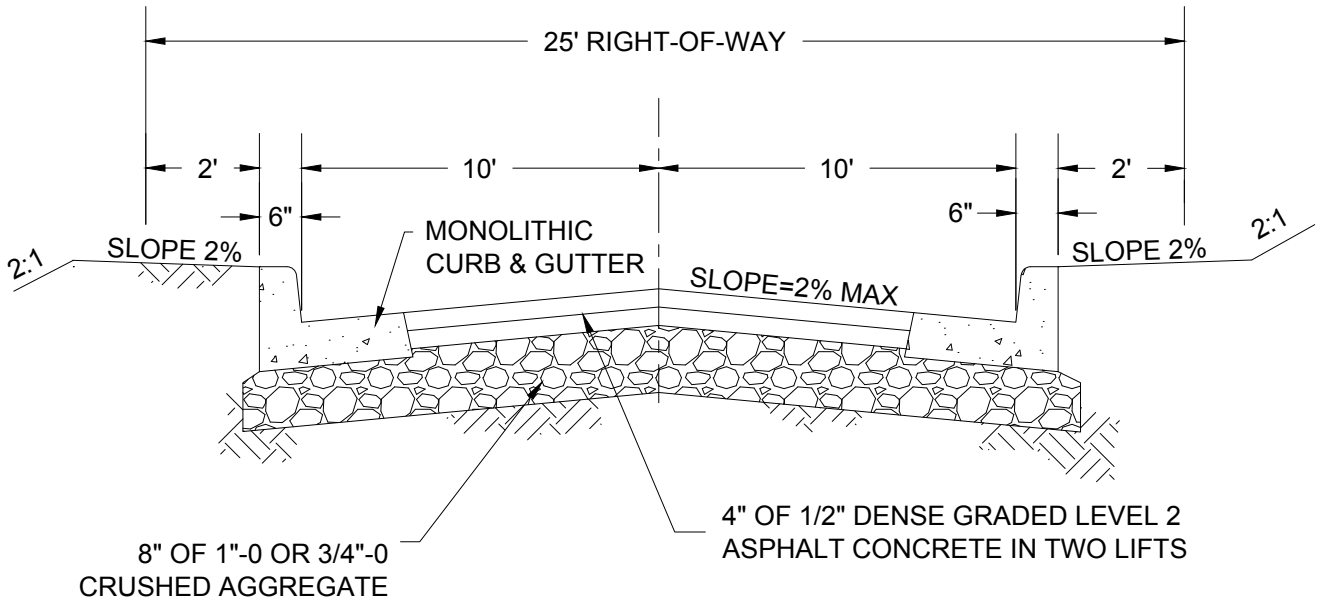

NOTES:

1. ASPHALT CONCRETE SHALL BE COMPACTED TO 91% OF RICE DENSITY.
2. SUBGRADE AND BASEROCK SHALL BE COMPACTED TO 95% RELATIVE DENSITY PER ASTM D1557.
3. NO FIRE HYDRANTS ARE TO BE LOCATED ON A MINOR ACCESS STREET.
4. PUBLIC PARKING FOR VISITORS (MIN. 3 SPACES) AND A BRANCH TURNAROUND SHALL BE PROVIDED AT THE END OF THE MINOR ACCESS STREET. SEE STANDARD DETAIL 616. ADDITIONAL RIGHT-OF-WAY SHALL BE DEDICATED TO ACCOMMODATE ADDITIONAL PARKING.
5. A "DEAD END" SIGN SHALL BE POSTED AT THE ENTRANCE TO THE MINOR ACCESS STREET.
6. "NO PARKING" SHALL BE POSTED FOR THE ENTIRE LENGTH OF THE MINOR ACCESS STREET.
7. ONE ADDITIONAL OFF-STREET PARKING SPACE IS REQUIRED FOR EACH RESIDENTIAL UNIT THAT ACCESSES A MINOR ACCESS STREET.
8. ON DEVELOPMENT SITES WITH STEEP SLOPES, A SHED-SECTION MAY BE BUILT RATHER THAN A CROWNED CROSS-SECTION. IN THOSE CASES, THE MAXIMUM CROSS-SLOPE SHALL BE 5% AND NO WEEPHOLES ARE ALLOWED IN THE CURB ON THE UPHILL SIDE.

NTS

	<p>MINOR ACCESS STREET SECTION</p> <p>PWS VERSION: JULY 2026</p>	<p>DRAWN AAD</p>
		<p>REV. DATE MARCH 2026</p>
		<p>APPR.</p>
		<p>DETAIL NO. 604</p>

FILENAME: y:\inter-departmental\development engineering projects\public works standards\2.0 pws revision copy\details\cad - all\600_transportation\605.dwg, Plotted 4/20/2026 11:17 AM, By: Anthony Dollowitch, ANSI FULL BLEED A (8.50 X 11.00 INCHES)

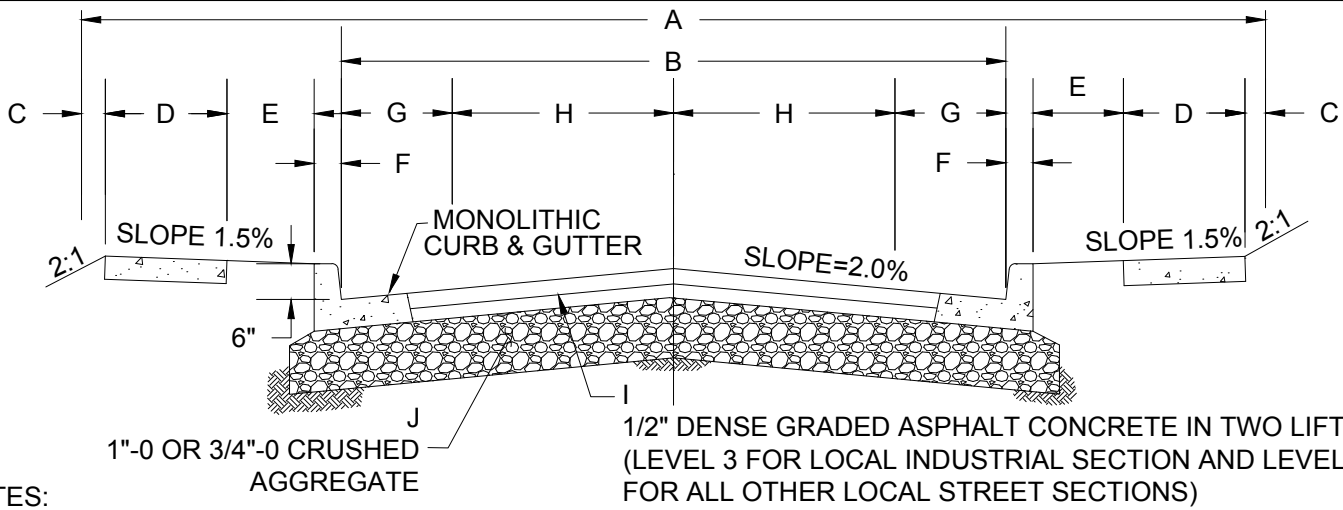

NOTES:

1. ASPHALT CONCRETE SHALL BE COMPACTED TO 91% OF RELATIVE DENSITY.
2. SUBGRADE AND BASEROCK SHALL BE COMPACTED TO 95% RELATIVE DENSITY PER ASTM D1557.
3. IN HILLSIDE AND GEOLOGIC RISK OVERLAY DISTRICTS, RIGHT-OF-WAY WIDTH MAY BE 40' WITH A PAVEMENT WIDTH OF 28' AND 5' SIDEWALKS ON BOTH SIDES. CROSS SECTION WILL STILL BE REQUIRED TO PROVIDE ONE PARKING LANE TO ASSURE THAT ON-STREET PARKING IS ADEQUATE FOR ADJACENT USES, A REDUCED STREET DESIGN MAY CONSIDER CLUSTERED PARKING BAYS ADJACENT TO THE STREET, IF NEEDED.
4. THE SIDEWALK SHALL HAVE A MINIMUM 5' AREA CLEAR OF ALL OBSTACLES UNLESS APPROVED BY THE ENGINEER.
5. WHEN A HYDRANT IS LOCATED BEHIND THE SIDEWALK A 6' X 6' EASEMENT IS REQUIRED AROUND THE HYDRANT.
6. "NO PARKING" SHALL BE POSTED WITHIN 30 FEET OF THE CURB RETURN ON LOCAL STREETS.
7. MAXIMUM BLOCK LENGTH FOR A QUEUING STREET IS 400 FEET.
8. ON DEVELOPMENT SITES WITH STEEP SLOPES, A SHED-SECTION MAY BE BUILT RATHER THAN A CROWNED CROSS-SECTION. IN THOSE CASES, THE MAXIMUM CROSS-SLOPE SHALL BE 5% AND NO WEEPHOLES ARE ALLOWED IN THE CURB ON THE UPHILL SIDE.

STREET CROSS SECTION DIMENSIONS

FUNCTIONAL CLASSIFICATION	RIGHT-OF-WAY	CURB TO CURB	MONUMENTATION STRIP	SIDEWALK	LANDSCAPE		CURB	PARKING	TRAVEL LANE	ASPHALT CONCRETE	CRUSHED AGGREGATE
					IN PLEASANT VALLEY, SPRINGWATER AND KELLEY CREEK HEADWATERS SPECIAL DISTRICTS	IN REMAINING CITY					
					A	B					
LOCAL INDUSTRIAL	60'	40'	6"	5'	6'	4'	6"	8'	12'	8"	16"
LOCAL COMMERCIAL	56'	36'	6"	5'	6'	4'	6"	7'	11'	5"	16"
LOCAL TRANSITIONAL*	64'	32'	6"	5'	10'	10'	6"	7'	9'	4"	8"
LOCAL QUEUING*	58'	26'	6"	5'	10'	10'	6"	7'	6'	4"	8"

* WHEN A FULL BLOCK IS NOT BEING CONSTRUCTED, SEE CITY OF GRESHAM PWS SECTION 6.02.05

NTS



LOCAL STREET SECTIONS

PWS VERSION: JULY 2026

DRAWN	AAD
REV. DATE	APRIL 2026
APPR.	
DETAIL NO.	605

FILENAME: y:\inter-departmental\development engineering projects\public works standards\2.0 pws revision copy\details\cad - all\600_transportation\606.dwg, Plotted 4/20/2026 11:17 AM, By: Anthony Dollowitch, ANSI FULL BLEED A (8.50 X 11.00 INCHES)

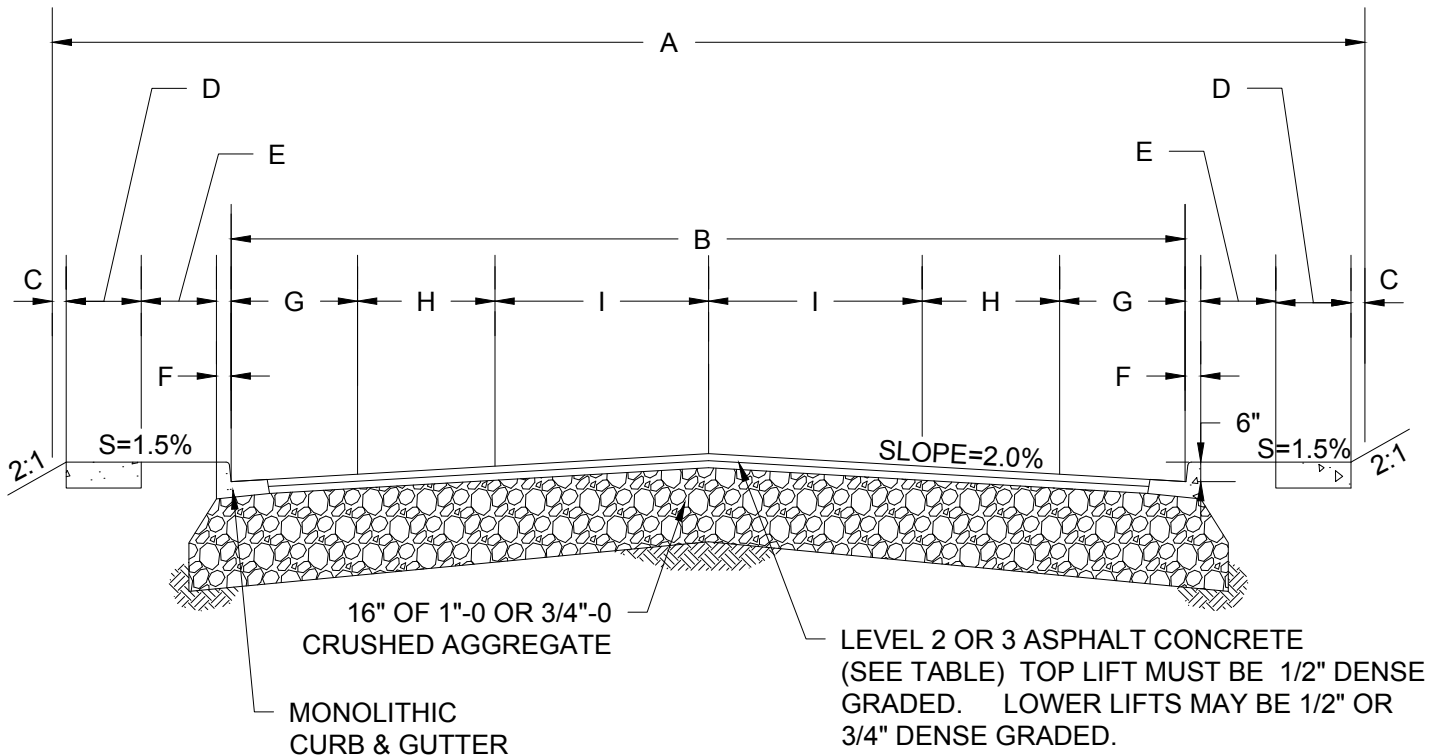

LEVEL 2 OR 3 ASPHALT CONCRETE (SEE TABLE) TOP LIFT MUST BE 1/2" DENSE GRADED. LOWER LIFTS MAY BE 1/2" OR 3/4" DENSE GRADED.

NOTES:

1. ASPHALT CONCRETE SHALL BE COMPACTED TO 91% OF RICE DENSITY.
2. SUBGRADE AND BASEROCK SHALL BE COMPACTED TO 95% RELATIVE DENSITY PER ASTM D1557.
3. THE SIDEWALK SHALL HAVE A MINIMUM 5' CLEAR OF ALL OBSTACLES UNLESS APPROVED BY THE ENGINEER.
4. "NO PARKING" SHALL BE POSTED WITHIN 45 FEET OF THE CURB RETURN ON COLLECTOR STREETS.
5. IN THE DOWNTOWN PLAN AREA, MINOR AND STANDARD COLLECTOR SIDEWALKS SHALL BE 6', WITH LANDSCAPE WIDTHS REDUCED TO 5'.
6. IN DOWNTOWN AND CIVIC PLAN AREAS, CURBED BULB-OUTS SHALL BE PROVIDED AT ALL AT STREET INTERSECTIONS AND CROSSWALKS.

* THE CITY MAY REQUIRE LEVEL 3 FOR STANDARD COLLECTORS

NTS

STREET CROSS SECTION DIMENSIONS				
CLASSIFICATION DESIGNATION		MAJOR COLLECTOR	STANDARD COLLECTOR	MINOR COLLECTOR
RIGHT-OF-WAY	A	74'	60'	60'
CURB TO CURB	B	48'	36'	36'
MONUMENTATION STRIP	C	6"	6"	6"
SIDEWALK	D	6'	5'	5'
LANDSCAPE	E	6'	6'	6'
CURB	F	6"	6"	6"
PARKING	G	7'	N/A	7'
BIKE LANE	H	6'	6'	N/A
TRAVEL LANE	I	11'	12'	11'
ASPHALT DEPTH		8"	5"	5"
ASPHALT LEVEL		LEVEL 3	LEVEL 2*	LEVEL 2

	<h2>COLLECTOR STREET SECTIONS</h2>	DRAWN AAD
		REV. DATE OCT 2025
		APPR.
		DETAIL NO. 606
PWS VERSION: JULY 2026		

FILENAME: y:\inter-departmental\development engineering projects\public works standards\2.0 pws revision copy\details\cad - all\600_transportation\607.dwg, Plotted: 4/20/2026 11:17 AM, By: Anthony Dollowitch, ANSI FULL BLEED A (8.50 X 11.00 INCHES)

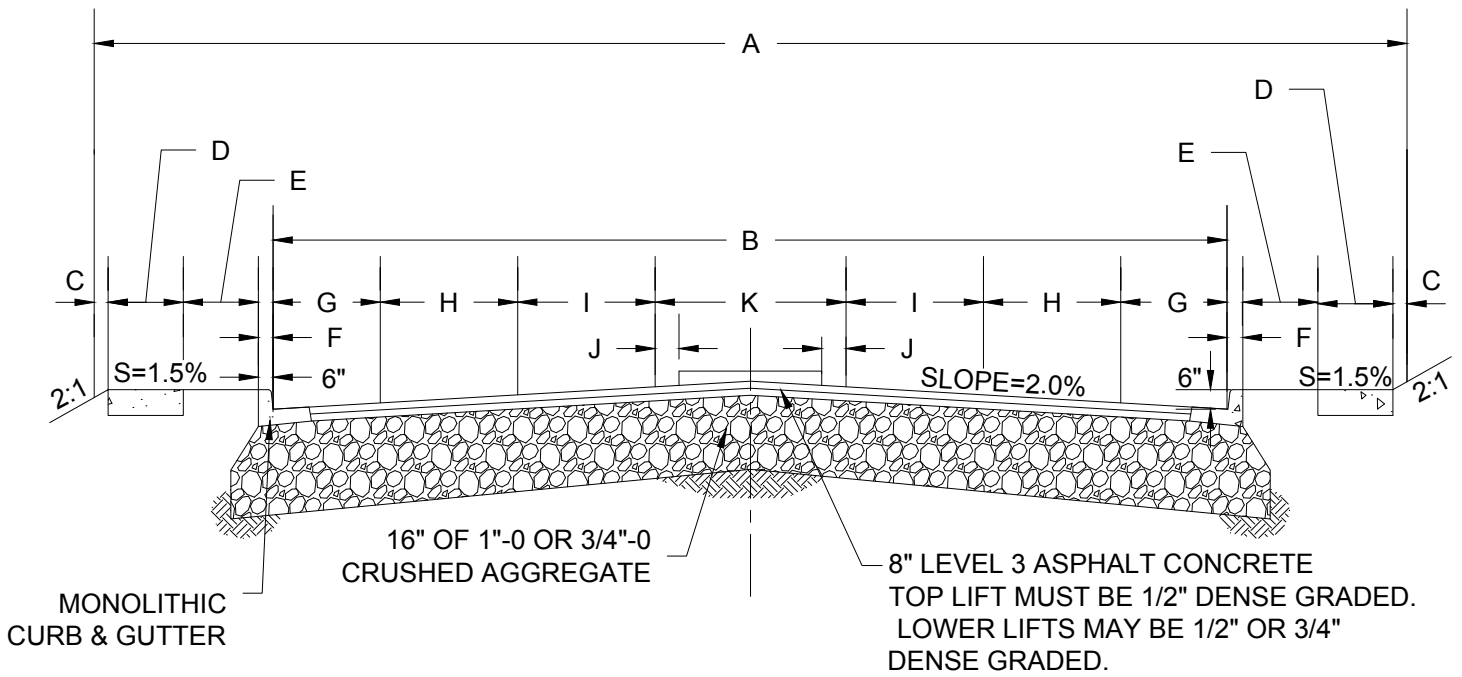

STREET CROSS SECTION DIMENSIONS				
CLASSIFICATION DESIGNATION		MAJOR ARTERIAL	STANDARD ARTERIAL	MINOR ARTERIAL
RIGHT-OF-WAY	A	104'	96'	74'
CURB TO CURB	B	74'	66'	48'
MONUMENTATION STRIP	C	6"	6"	6"
SIDEWALK	D	6'	6'	6'
LANDSCAPE	E	8'	8'	6'
CURB	F	6"	6"	6"
BIKE LANE	G	6'	6'	6'
TRAVEL LANE 1	H	12'	11'	11'
TRAVEL LANE 2	I	12'	10'	N/A
SHY DISTANCE	J	1'	1'	3'
CENTER	K	14'	12'	14'

NOTES:

1. ASPHALT CONCRETE SHALL BE COMPACTED TO 91% OF RICE DENSITY.
2. SUBGRADE AND BASEROCK SHALL BE COMPACTED TO 95% RELATIVE DENSITY PER ASTM D1557.
3. THE SIDEWALK SHALL HAVE A MINIMUM 5' CLEAR OF ALL OBSTACLES UNLESS APPROVED BY THE ENGINEER.
4. A RAISED MEDIAN OR TWO-WAY LEFT TURN LANE SHALL SEPARATE OPPOSING LANES.

NTS



ARTERIAL STREET SECTIONS

PWS VERSION: JULY 2026

DRAWN	AAD
REV. DATE	JULY 2025
APPR.	
DETAIL NO.	607

FILENAME: y:\inter-departmental\development engineering projects\public works standards\2.0 pws revision copy\details\cad - all\600_transportation\608.dwg, Plotted 4/20/2026 11:17 AM, By: Anthony Dollowitch, ANSI FULL BLEED A (8.50 X 11.00 INCHES)

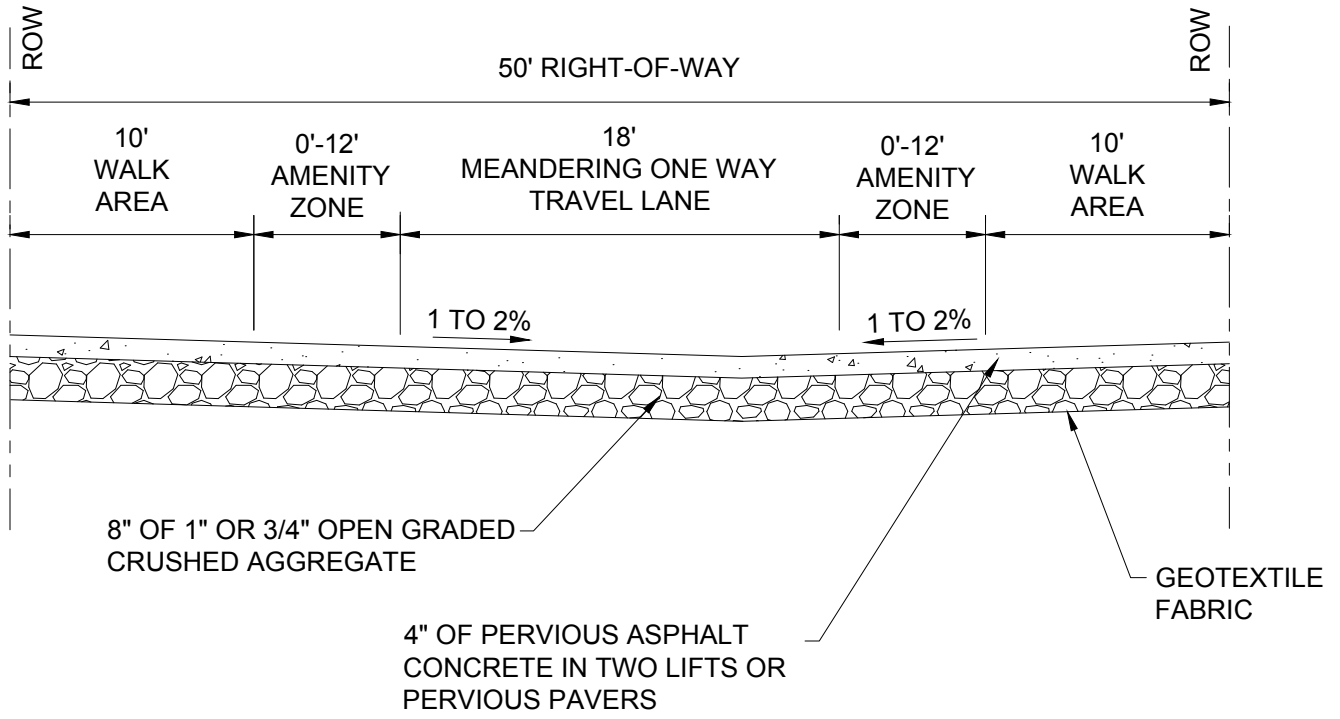

NOTES:

1. SUBGRADE AND BASEROCK SHALL BE COMPACTED TO 95% RELATIVE DENSITY PER ASTM D1557.
2. WIDTH OF AMENITY ZONE IS BASED ON THE MEANDERING TRAVEL LANE.

NTS



SHARED STREET SECTION

PWS VERSION: JULY 2026

DRAWN	AAD
REV. DATE	JULY 2025
APPR.	
DETAIL NO.	608

FILENAME: y:\inter-departmental\development engineering projects\public works standards\2.0 pws revision copy\details\cad - all\600_transportation\609.dwg, Plotted 4/20/2026 11:17 AM, By: Anthony Dollowitch, ANSI FULL BLEED A (8.50 X 11.00 INCHES)

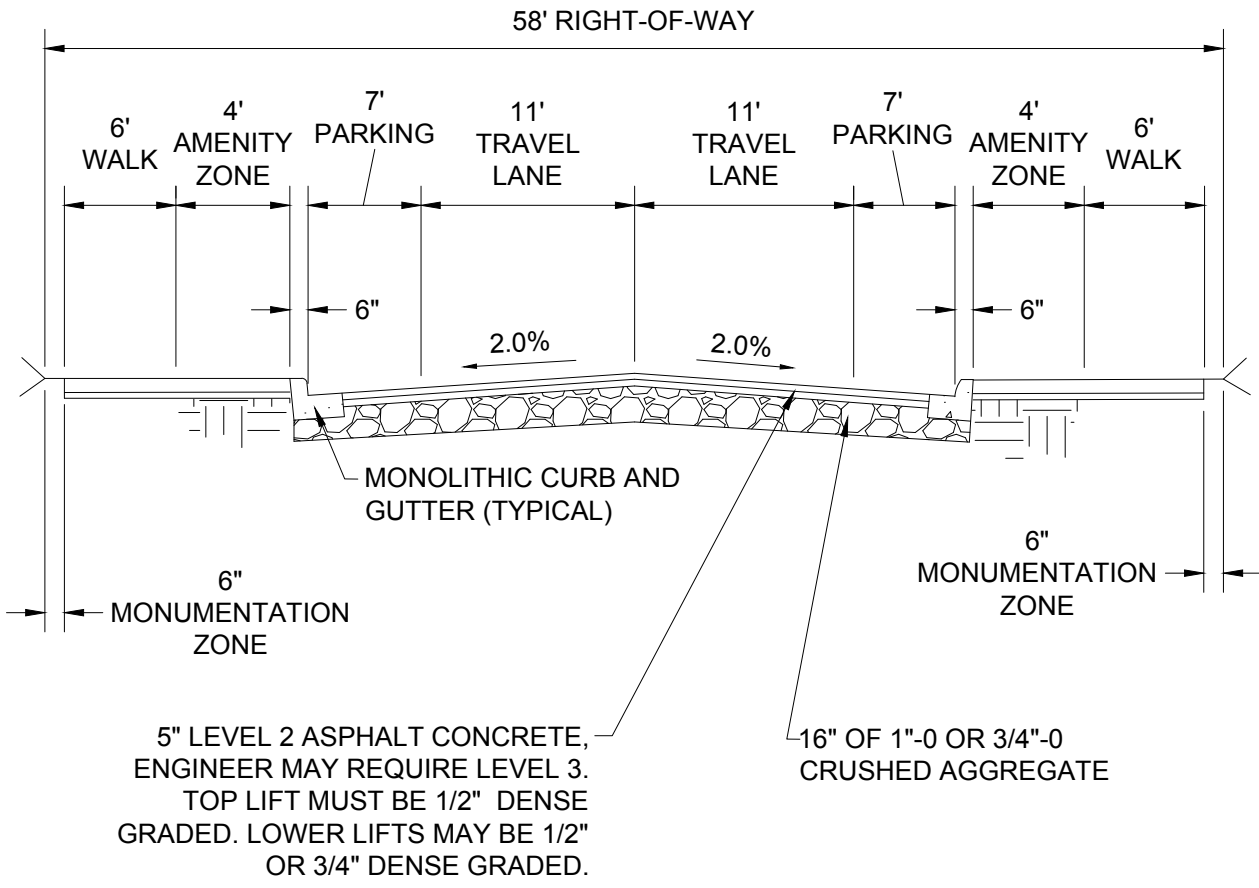

NOTES:

1. ASPHALT CONCRETE SHALL BE COMPACTED TO 91% OF RICE DENSITY.
2. SUBGRADE AND BASEROCK SHALL BE COMPACTED TO 95% RELATIVE DENSITY PER ASTM D1557.
3. AT ROW LINE MAXIMUM SLOPE CUT 2:1, FILL 3:1.
4. CURBED BULB-OUTS SHALL BE PROVIDED AT ALL AT STREET INTERSECTIONS AND CROSSWALKS.

NTS

	<p>DOWNTOWN/CIVIC LOCAL STREET SECTION</p> <p>PWS VERSION: JULY 2026</p>	<p>DRAWN AAD</p>
		<p>REV. DATE OCT 2025</p>
		<p>APPR.</p>
		<p>DETAIL NO. 609</p>

FILENAME: y:\inter-departmental\development engineering projects\public works standards\2.0 pws revision copy\details\cad - all\600_transportation\610.dwg, Plotted 4/20/2026 11:17 AM, By: Anthony Dollowitch, ANSI FULL BLEED A (8.50 X 11.00 INCHES)

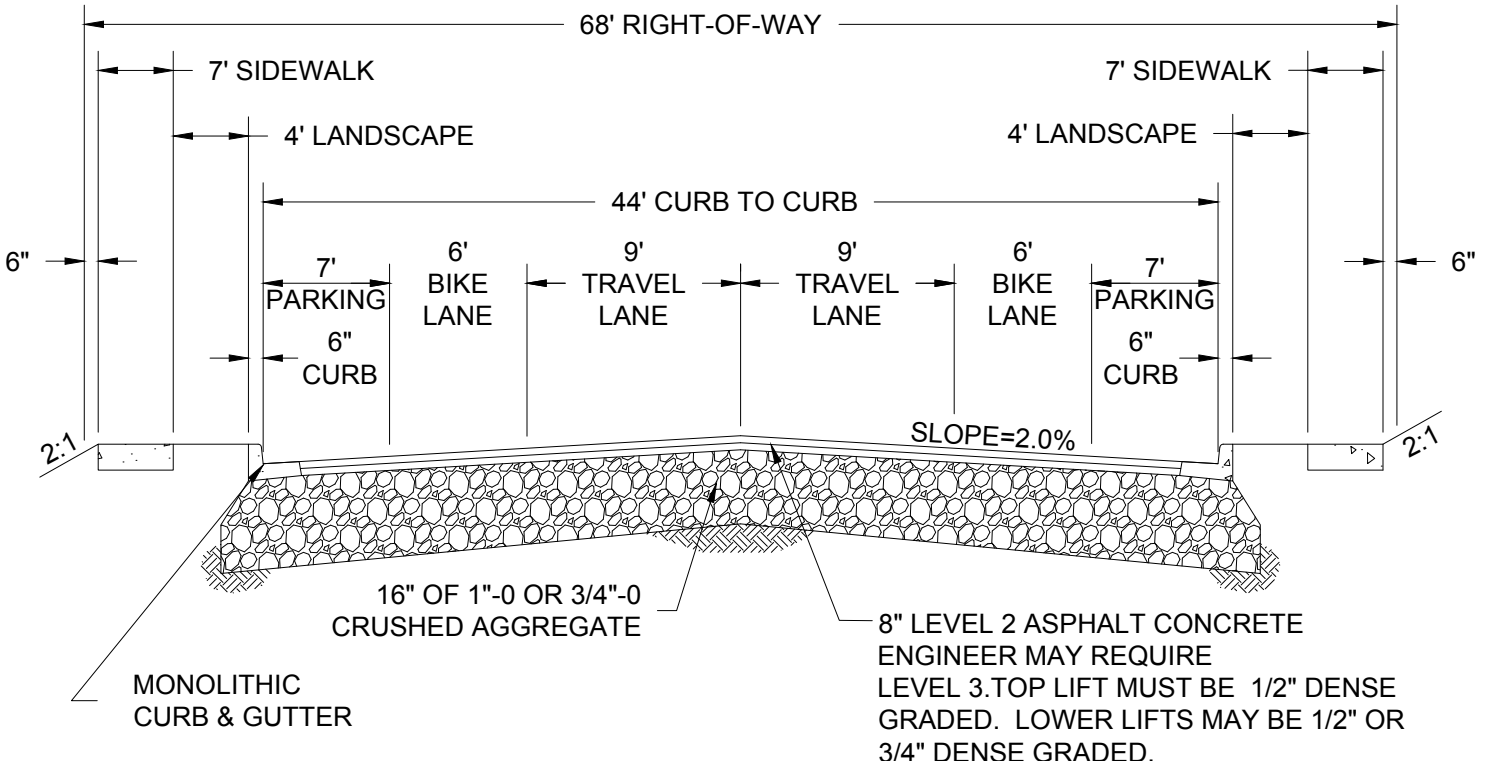

NOTES:

1. ASPHALT CONCRETE SHALL BE COMPACTED TO 91% OF RICE DENSITY.
2. SUBGRADE AND BASEROCK SHALL BE COMPACTED TO 95% RELATIVE DENSITY PER ASTM D1557.
3. THE SIDEWALK SHALL HAVE A MINIMUM 5' CLEAR OF ALL OBSTACLES UNLESS APPROVED BY THE ENGINEER.
4. CURBED BULB-OUTS SHALL BE PROVIDED AT ALL AT STREET INTERSECTIONS AND CROSSWALKS.

NTS

	<p>CIVIC CONNECTOR STREET SECTION</p> <p>PWS VERSION: JULY 2026</p>	<p>DRAWN AAD</p>
		<p>REV. DATE AUG 2025</p>
		<p>APPR.</p>
		<p>DETAIL NO. 610</p>

FILENAME: y:\inter-departmental\development engineering projects\public works standards\2.0 pws revision copy\details\cad - all\600_transportation\611.dwg. Plotted 4/20/2026 11:17 AM, By: Anthony Dollowitch, ANSI FULL BLEED A (8.50 X 11.00 INCHES)

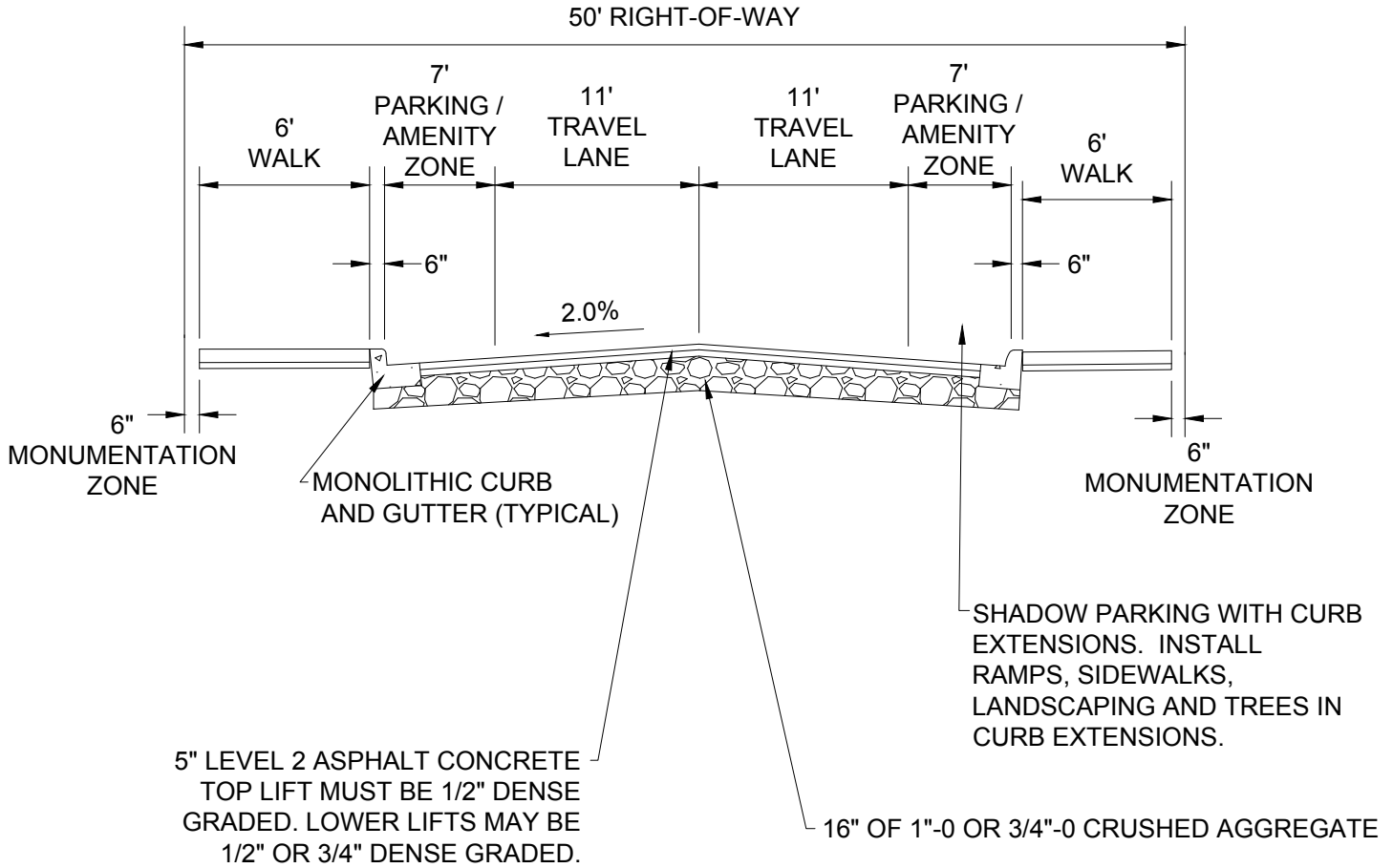

NOTES:

1. ASPHALT CONCRETE SHALL BE COMPACTED TO 91% OF RICE DENSITY.
2. SUBGRADE AND BASEROCK SHALL BE COMPACTED TO 95% RELATIVE DENSITY PER ASTM D1557.
3. STREET TREES SHALL BE PLANTED IN CURB EXTENSIONS.
4. AT ROW LINE MAXIMUM SLOPE CUT 2:1, FILL 3:1.
5. SIDEWALK SHALL MAINTAIN A 4' CLEAR ADA CONTINUOUS PATHWAY.
6. CURBED BULB-OUTS SHALL BE PROVIDED AT ALL AT STREET INTERSECTIONS AND CROSSWALKS.

NTS



**DOWNTOWN MAIN (POWELL TO 4TH)
STREET SECTION**

PWS VERSION: JULY 2026

DRAWN	AAD
REV. DATE	OCT 2025
APPR.	
DETAIL NO.	611

FILENAME: y:\inter-departmental\development engineering projects\public works standards\2.0 pws revision copy\details\cad - all\600_transportation\612.dwg. Plotted 4/20/2026 11:17 AM, By: Anthony Dollowitch, ANSI FULL BLEED A (8.50 X 11.00 INCHES)

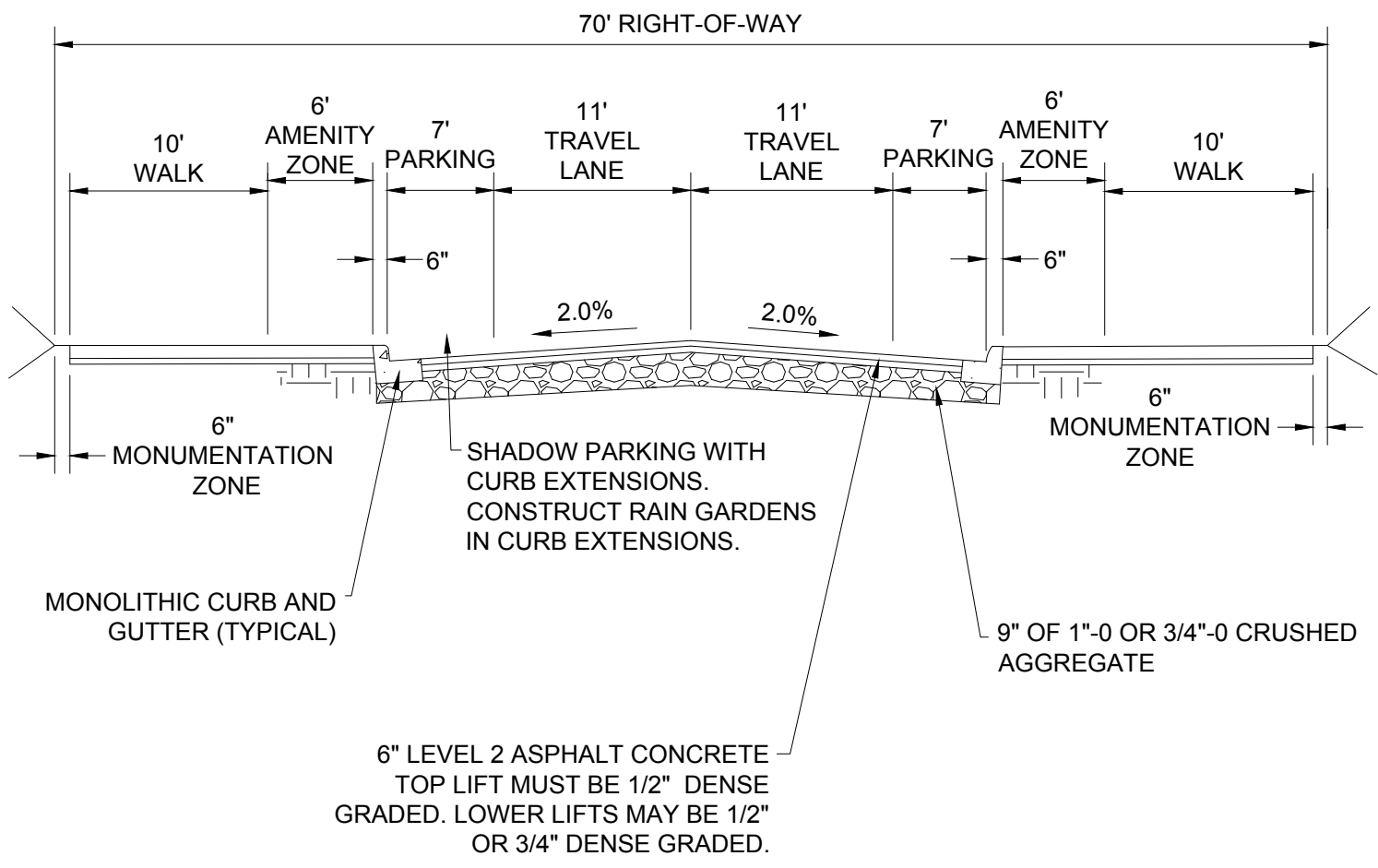

NOTES:

1. ASPHALT CONCRETE SHALL BE COMPACTED TO 91% OF RICE DENSITY.
2. SUBGRADE AND BASEROCK SHALL BE COMPACTED TO 95% RELATIVE DENSITY PER ASTM D1557.
3. AT ROW LINE MAXIMUM SLOPE CUT 2:1, FILL 3:1.
4. CURBED BULB-OUTS SHALL BE PROVIDED AT ALL AT STREET INTERSECTIONS AND CROSSWALKS.

NTS

	<p>DOWNTOWN STANLEY STREET SECTION</p> <p>PWS VERSION: JULY 2026</p>	<p>DRAWN AAD</p>
		<p>REV. DATE OCT 2025</p>
		<p>APPR.</p>
		<p>DETAIL NO. 612</p>

FILENAME: y:\inter-departmental\development engineering projects\public works standards\2.0 pws revision copy\details\cad - all\600_transportation\613.dwg, Plotted 4/20/2026 11:17 AM, By: Anthony Dollowitch, ANSI FULL BLEED A (8.50 X 11.00 INCHES)

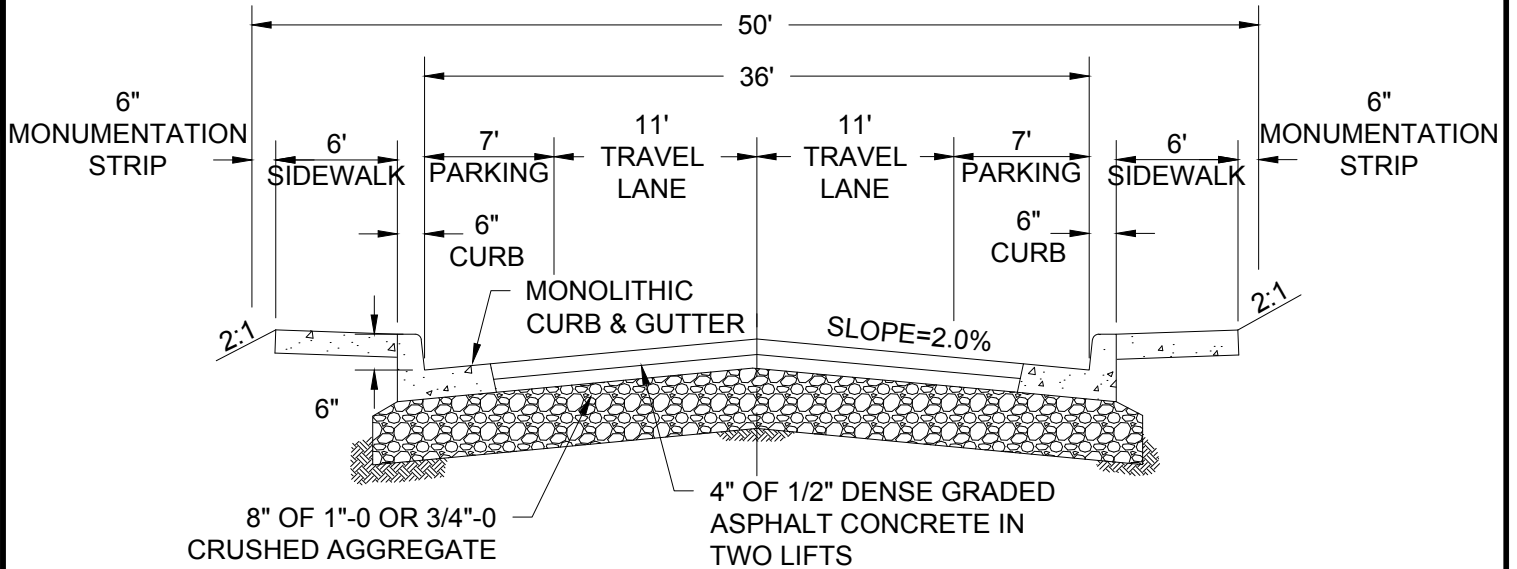

NOTES:

1. ASPHALT CONCRETE SHALL BE COMPACTED TO 91% OF RELATIVE DENSITY.
2. SUBGRADE AND BASEROCK SHALL BE COMPACTED TO 95% RELATIVE DENSITY PER ASTM D1557.
3. THE SIDEWALK SHALL HAVE A MINIMUM 5' AREA CLEAR OF ALL OBSTACLES UNLESS APPROVED BY THE ENGINEER.
4. WHEN A HYDRANT IS LOCATED BEHIND THE SIDEWALK A 6' X 6' EASEMENT IS REQUIRED AROUND THE HYDRANT.

NTS



**ROBERTS (POWELL TO REGNER)
STREET SECTION**

PWS VERSION: JULY 2026

DRAWN	AAD
REV. DATE	JULY 2025
APPR.	
DETAIL NO.	613

FILENAME: y:\inter-departmental\development engineering projects\public works standards\20 pws revision copy\details\cad - all\600_transportation\614.dwg, Plotted 4/20/2026 11:17 AM, By: Anthony Dollowitch, ANSI FULL BLEED A (8.50 X 11.00 INCHES)

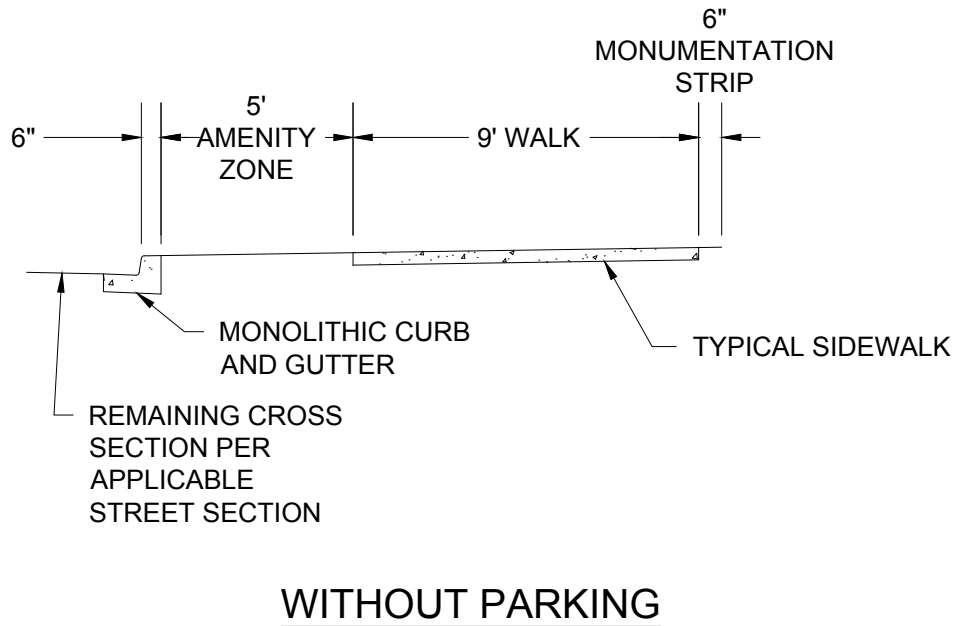
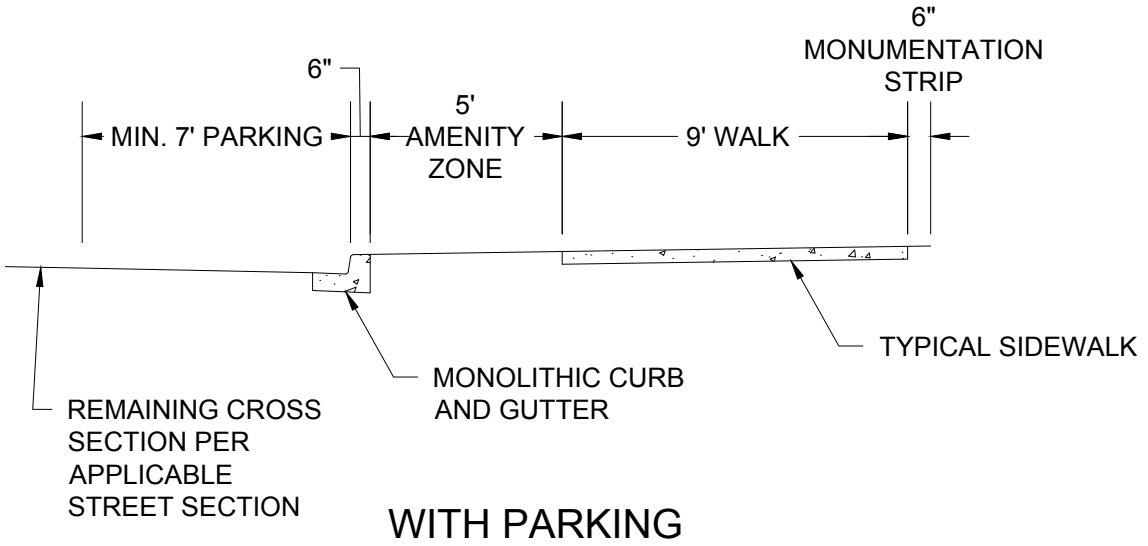

NOTE:

1. AMENITY ZONES SHALL INCLUDE 5' X 5' TREE WELLS.
2. ADDITIONAL RIGHT-OF-WAY DEDICATION IS REQUIRED ON COLLECTORS AND MINOR ARTERIALS.
3. BOULEVARDS IN THE SPRINGWATER PLAN DISTRICT AND ALONG E/W POWELL BLVD ARE REQUIRED TO INCLUDE PARKING.
6. IN DOWNTOWN AND CIVIC PLAN AREAS, CURBED BULB-OUTS SHALL BE PROVIDED AT ALL AT STREET INTERSECTIONS AND CROSSWALKS.

NTS

**CITY OF
GRESHAM**

BOULEVARD

PWS VERSION: JULY 2026

DRAWN	AAD
REV. DATE	JAN 2025
APPR.	
DETAIL NO.	614

FILENAME: y:\inter-departmental\development engineering projects\public works standards\2.0 pws revision copy\details\cad - all\600_transportation\615.dwg, Plotted: 4/20/2026 11:17 AM, By: Anthony Dollowitch, ANSI FULL BLEED A (8.50 X 11.00 INCHES)

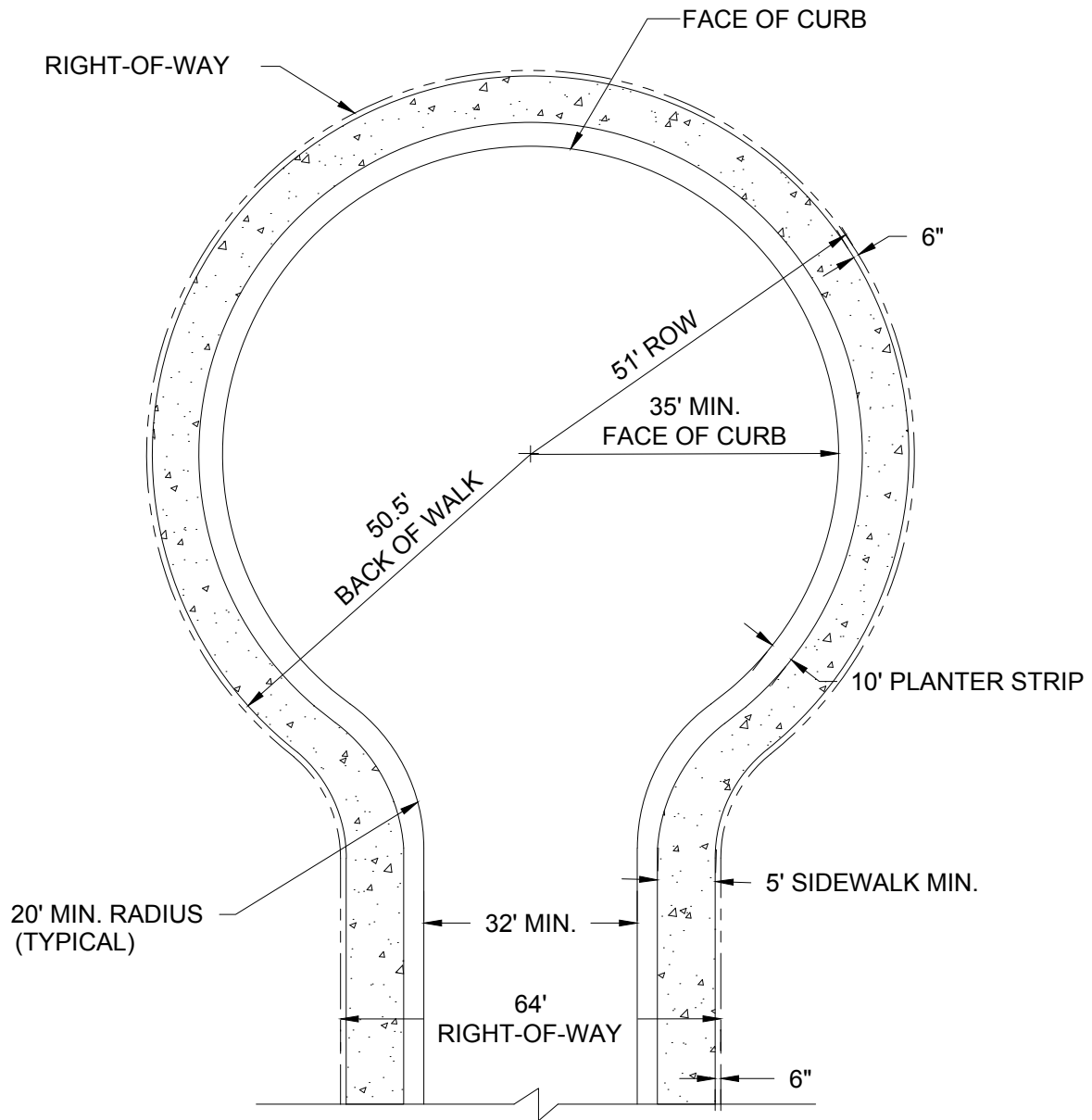

NOTES:

1. A 28' WIDTH MAY BE ALLOWED WITHIN THE HILLSIDE AND GEOLOGIC RISK OVERLAY DISTRICTS WITH ENGINEER'S APPROVAL.
2. THE SIDEWALK IS TO BE LOCATED NEXT TO THE CURB ON THE ENTIRE LENGTH OF THE CUL-DE-SAC IN HILLSIDE AND GEOLOGIC RISK DISTRICTS.
3. A "DEAD-END" SIGN MAY BE REQUIRED AT ENTRANCE TO THE STREET ENDING IN A CUL-DE-SAC.
4. "NO PARKING" SHALL BE POSTED FOR THE ENTIRE CUL-DE-SAC BULB.
5. THE SIDEWALK SHALL HAVE A MINIMUM 5' CLEAR OF ALL OBSTACLES, UNLESS APPROVED BY THE ENGINEER.
6. NO FIRE HYDRANTS ARE TO BE LOCATED IN THE CUL-DE-SAC BULB.

NTS

**CITY OF
GRESHAM**

STANDARD CUL-DE-SAC

PWS VERSION: JULY 2026

DRAWN	AAD
REV. DATE	OCT 2025
APPR.	
DETAIL NO.	615

FILENAME: y:\inter-departmental\development engineering projects\public works standards\2.0 pws revision copy\details\cad - all\600_transportation\6.16.dwg, Plotted 4/20/2026 11:17 AM, By: Anthony Dollowitch, ANSI FULL BLEED A (8.50 X 11.00 INCHES)

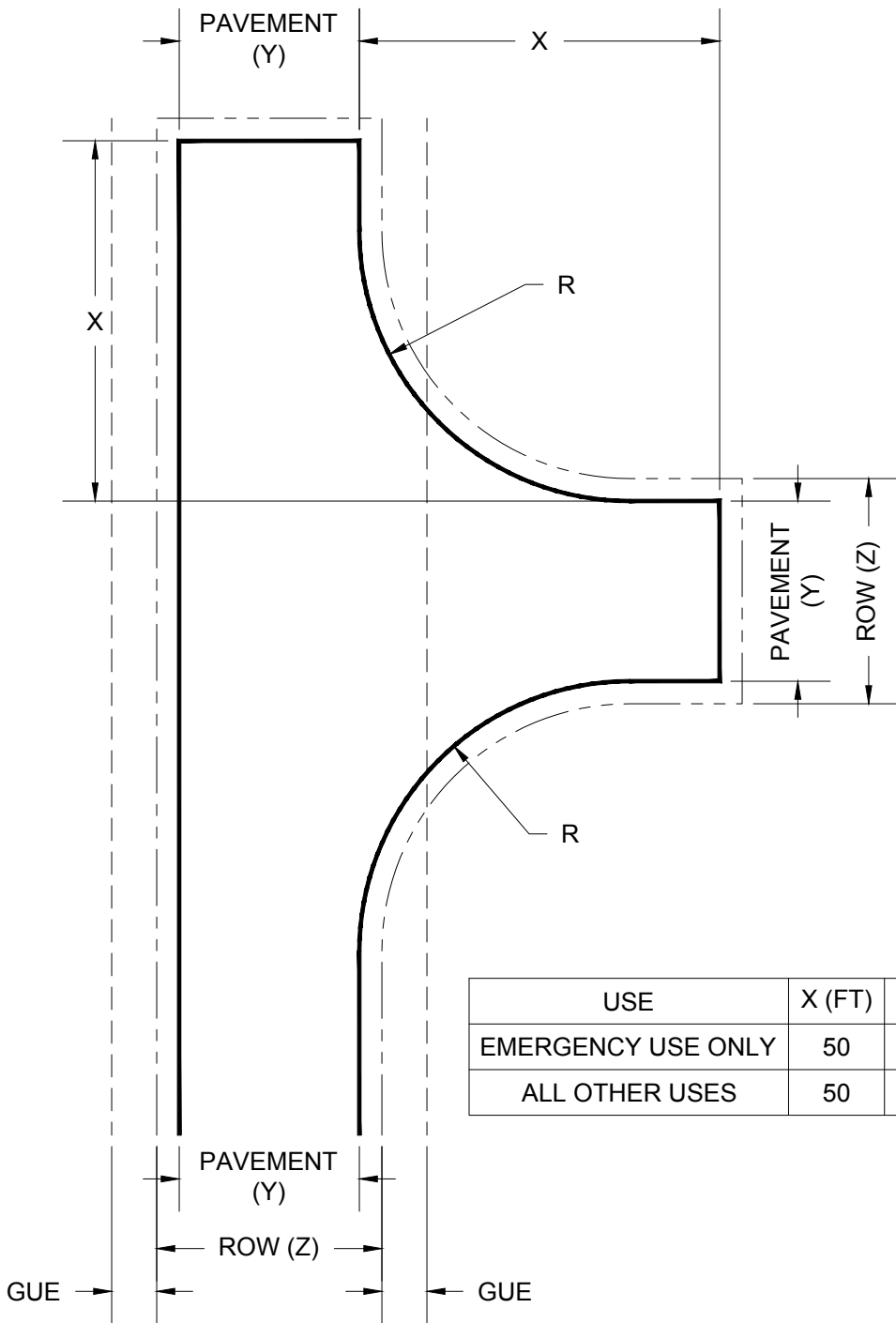

USE	X (FT)	R (FT)	Y (FT)	Z (FT)
EMERGENCY USE ONLY	50	28	20	25
ALL OTHER USES	50	30	20	25

NOTES:

- BRANCH TURNAROUND TO BE USED FOR EMERGENCY, MAINTENANCE, RECYCLING AND SOLID WASTE SERVICE ACCESS ON TEMPORARY DEAD-END STREETS (EXCEPT THOSE THAT ARE LESS THAN 150 FEET IN LENGTH AND DO NOT SERVE ANY PROPERTY ACCESS), AT THE END OF ALL MINOR ACCESS STREETS, AND WHEN DETERMINED BY THE CITY.
- PAVEMENT SECTION SHALL MATCH STREET CLASSIFICATION REQUIREMENTS.
- THE PAVEMENT AREA AND RIGHT-OF-WAY LIMITS ON A DEAD END STREET SHALL BE ABLE TO ACCOMMODATE THE BRANCH TURNAROUND FOOTPRINT REQUIREMENTS SHOWN ABOVE.

NTS



BRANCH TURNAROUND

PWS VERSION: JULY 2026

DRAWN	AAD
REV. DATE	OCT 2025
APPR.	
DETAIL NO.	616

FILENAME: y:\inter-departmental\development engineering projects\public works standards\20 pws revision copy\details\cad - all\600_transportation\617.dwg, Plotted 4/20/2026 11:17 AM, By: Anthony Dollowitch, ANSI FULL BLEED A (8.50 X 11.00 INCHES)

OPTION A

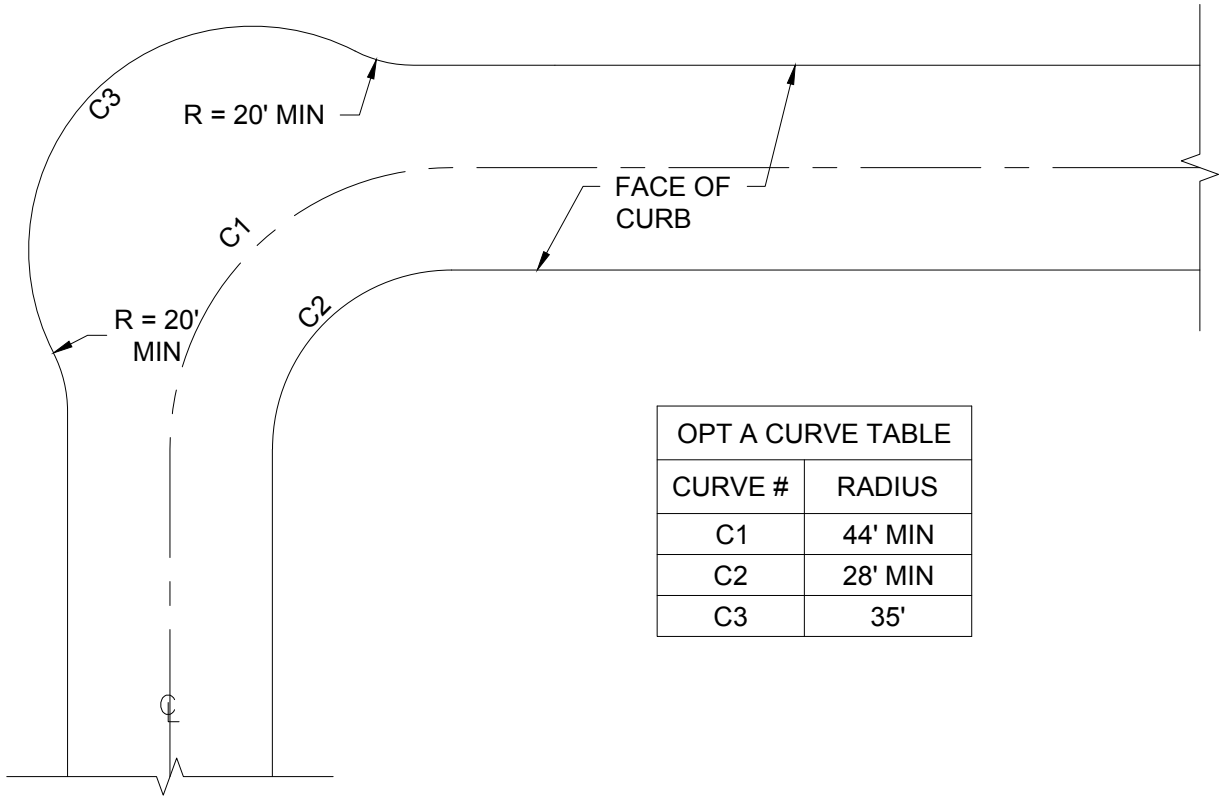

OPT A CURVE TABLE	
CURVE #	RADIUS
C1	44' MIN
C2	28' MIN
C3	35'

OPTION B

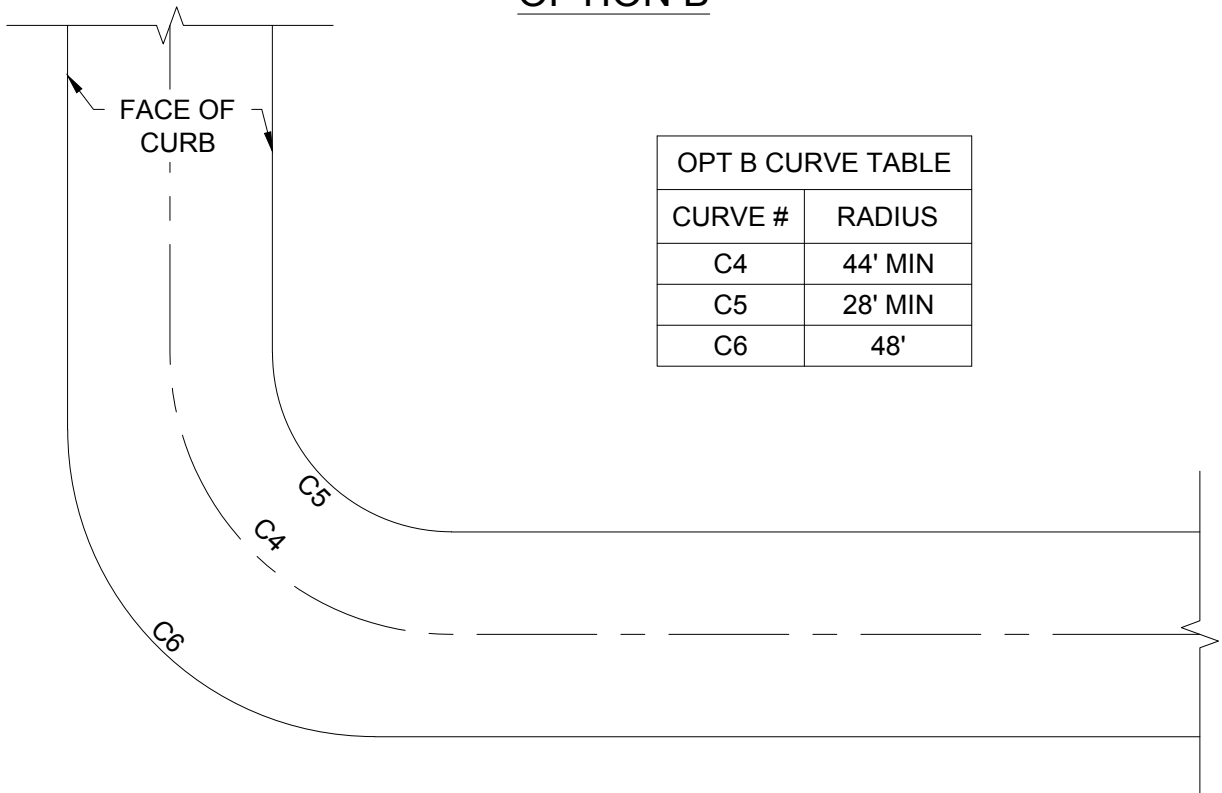

OPT B CURVE TABLE	
CURVE #	RADIUS
C4	44' MIN
C5	28' MIN
C6	48'

NTS

FILENAME: y:\inter-departmental\development engineering projects\public works standards\2.0 pws revision copy\details\cad - all\600_transportation\618a.dwg. Plotted 4/20/2026 11:17 AM. By: Anthony Dollowitch, ANSI FULL BLEED A (8.50 X 11.00 INCHES)

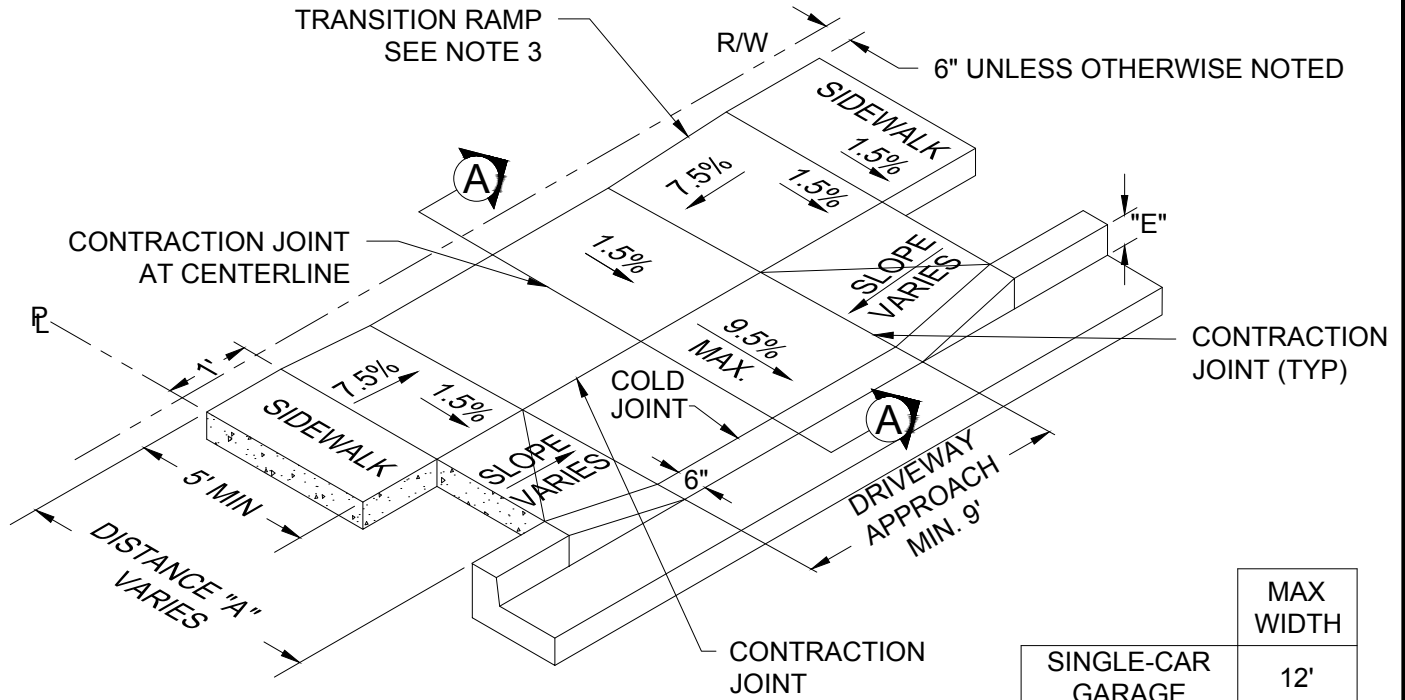

	MAX WIDTH
SINGLE-CAR GARAGE	12'
DOUBLE-CAR GARAGE	24'
TRIPLE-CAR* GARAGE	28'

*PLACE IN THREE PANELS

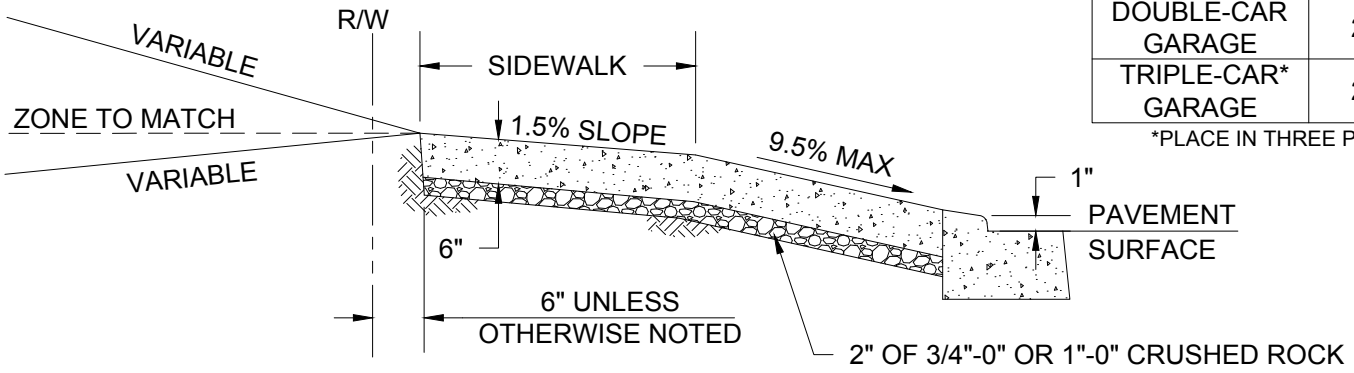

SECTION A - A

NOTES:

- DISTANCE "A" VARIES WITH STREET CLASSIFICATION. SEE STREET CROSS SECTION DETAILS.
- SEE STANDARD DETAILS 620 AND 621 FOR CURB EXPOSURE DIMENSION "E".
- SLOPES SHOWN ARE RELATIVE TO HORIZONTAL. TRANSITION RAMP SHALL BE 7.5% MAX SLOPE OR 15' MAX IN LENGTH. SIDE FLARES IN PLANTER STRIP MAY BE ANY SLOPE.
- ALL SURFACES SHALL BE LIGHTLY BROOMED AND EDGED IN A WORKMANLIKE MANNER.
- SAW CUT EXISTING CURBS WHERE THEY ARE TO BE REMOVED - IF LESS THAN 3' TO EXISTING JOINT, REMOVE TO JOINT. EXISTING ASPHALT IN FRONT OF THE APPROACH SHALL BE SAW CUT MINIMUM 24" FROM CURB FACE AND REPLACED WITH COMPACTED HOT MIX.
- PCC FOR RESIDENTIAL APPROACHES SHALL BE 4,000 PSI AT 28 DAYS.

NTS

CITY OF
GRESHAM

RESIDENTIAL DRIVEWAY APPROACH

PWS VERSION: JULY 2026

DRAWN	KRB
REV. DATE	OCT 2025
APPR.	
DETAIL NO.	618A

FILENAME: y:\inter-departmental\development_engineering_projects\public_works_standards\2.0_pws_revision_copy\details\cad - all\600_transportation\618b.dwg, Plotted 4/20/2026 11:17 AM, By: Anthony Dollowitch, ANSI FULL BLEED A (8.50 X 11.00 INCHES)

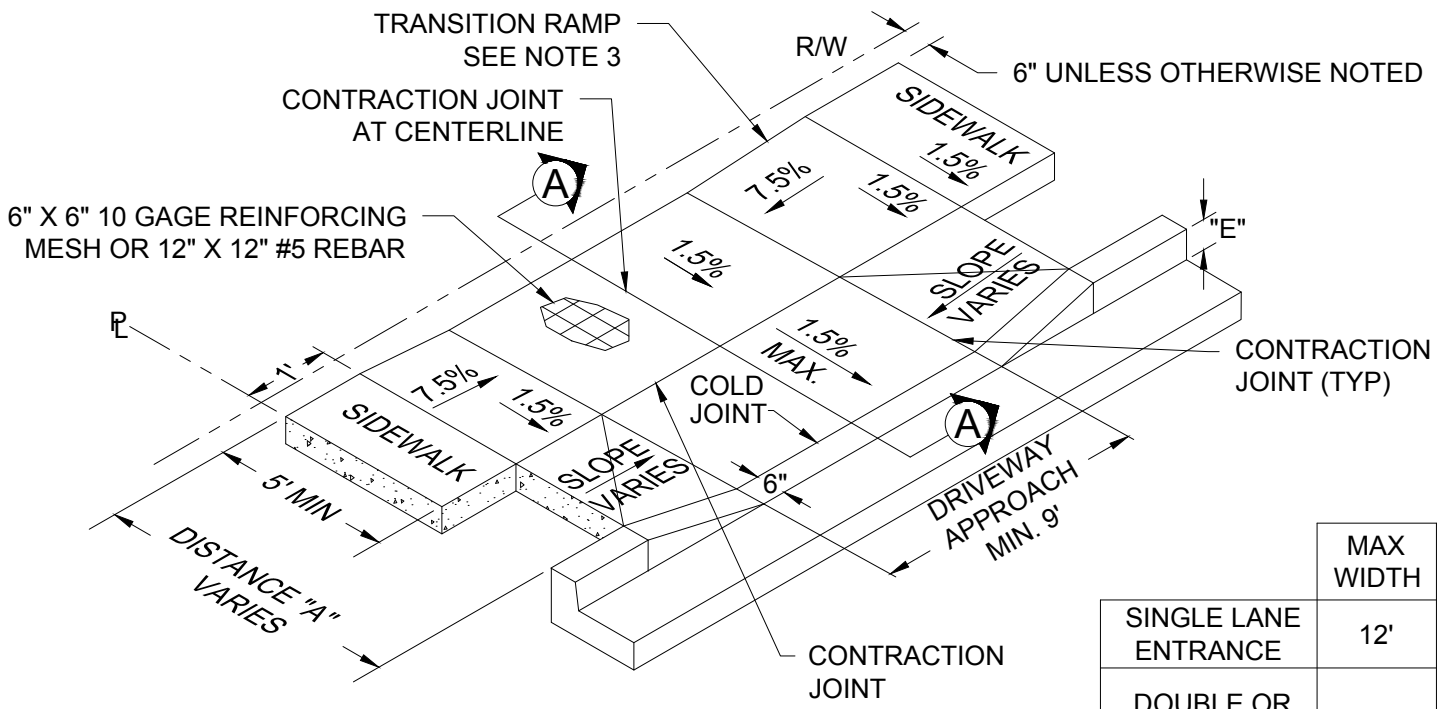

	MAX WIDTH
SINGLE LANE ENTRANCE	12'
DOUBLE OR TRIPLE* LANE ENTRANCE	36'

*TRIPLE LANE ENTRANCE TO BE PLACED IN THREE PANELS

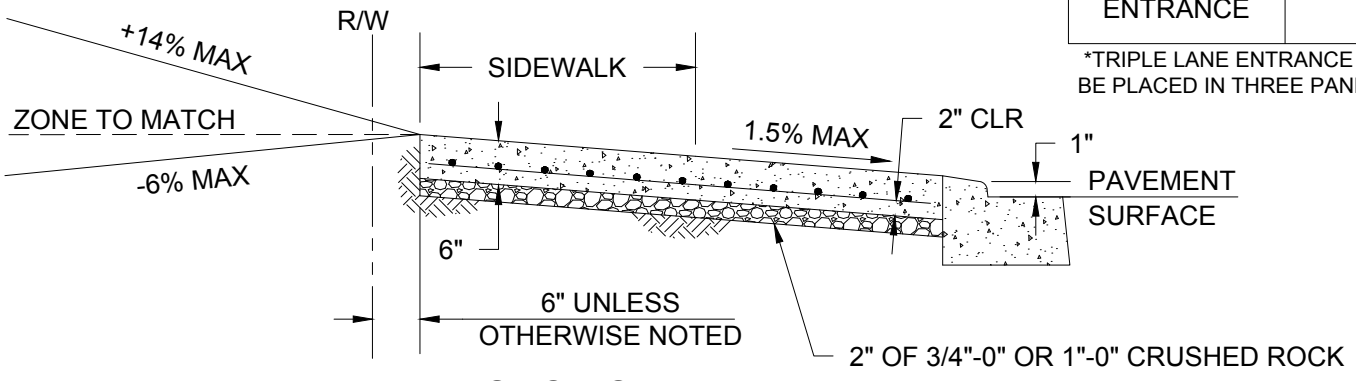

SECTION A - A

NOTES:

1. DISTANCE "A" VARIES WITH STREET CLASSIFICATION. SEE STREET CROSS SECTION DETAILS.
2. SEE STANDARD DETAILS 620 AND 621 FOR CURB EXPOSURE DIMENSION "E".
3. SLOPES SHOWN ARE RELATIVE TO HORIZONTAL. TRANSITION RAMP SHALL BE 7.5% MAX SLOPE OR 15' MAX IN LENGTH. SIDE FLARES IN PLANTER STRIP MAY BE ANY SLOPE.
4. ALL SURFACES SHALL BE LIGHTLY BROOMED AND EDGED IN A WORKMANLIKE MANNER.
5. SAW CUT EXISTING CURBS WHERE THEY ARE TO BE REMOVED - IF LESS THAN 3' TO EXISTING JOINT, REMOVE TO JOINT. EXISTING ASPHALT IN FRONT OF THE APPROACH SHALL BE SAW CUT MINIMUM 24" FROM CURB FACE AND REPLACED WITH COMPACTED HOT MIX.
6. PCC FOR COMMERCIAL, INDUSTRIAL, AND MULTIFAMILY APPROACHES SHALL BE 4,000 PSI AT 28 DAYS AND REINFORCED.
7. FOR SITES WITH HIGH VOLUME TRIP GENERATION, SEE DETAIL 619.
8. FOR SITES WITHIN THE DOWNTOWN, CIVIC, AND ROCKWOOD TOWN CENTERS, THE SLOPE OF THE DRIVEWAY BETWEEN THE SIDEWALK AND CURB MAY BE RAISED TO 6.0% TO REDUCE THE SLOPE OF THE TRANSITION RAMP.

NTS



COMMERCIAL, INDUSTRIAL, MULTIFAMILY DRIVEWAY APPROACH

PWS VERSION: JULY 2026

DRAWN	AAD
REV. DATE	JULY 2025
APPR.	
DETAIL NO.	618B

FILENAME: y:\inter-departmental\development engineering projects\public works standards\2.0 pws revision copy\details\cad - all\600_transportation\619.dwg, Plotted 4/20/2026 11:17 AM, By: Anthony Dollowitch, ANSI FULL BLEED A (8.50 X 11.00 INCHES)

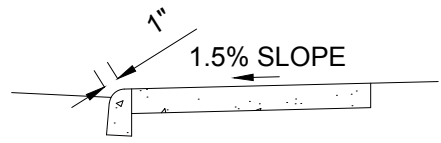

SECTION A-A

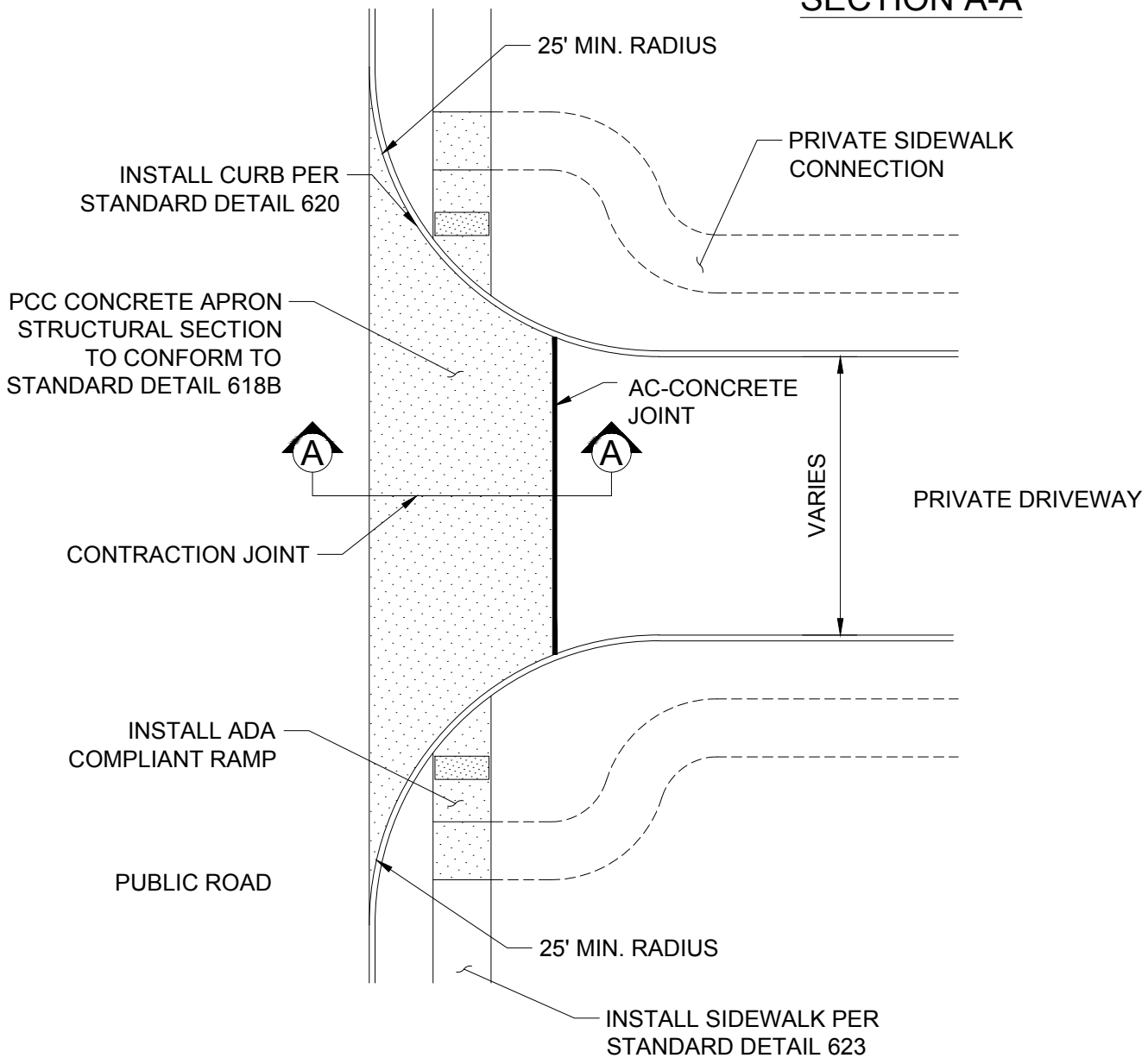

NOTES:

1. THIS TYPE OF APPROACH TO BE USED FOR HIGH VOLUME (500 ADT OR HIGHER) TRAFFIC GENERATORS WITH APPROVAL OF ENGINEER.

NTS



CURB RETURN DRIVEWAY APPROACH

PWS VERSION: JULY 2026

DRAWN	KRB
REV. DATE	JAN 2024
APPR.	
DETAIL NO.	619

FILENAME: y:\inter-departmental\development engineering projects\public works standards\2.0 pws revision copy\details\cad - all\600_transportation\620.dwg, Plotted 4/20/2026 11:17 AM, By: Anthony Dollowitch, ANSI FULL BLEED A (8.50 X 11.00 INCHES)

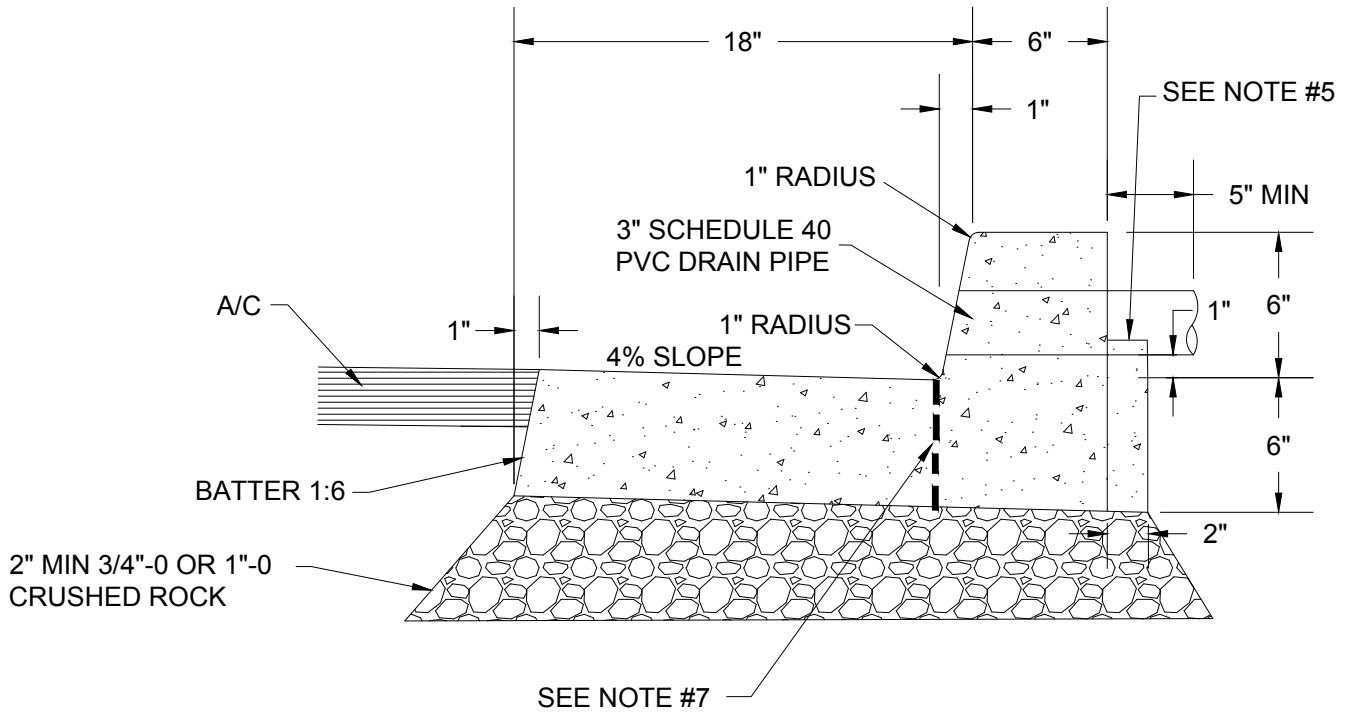

NOTES:

1. PCC SHALL BE 4,000 PSI STRENGTH AT 28 DAYS.
2. CONTRACTION JOINTS SHALL BE PLACED AT 15' MAX. SPACING.
3. CURB EXPOSURE SHALL BE 8" AT ALL STORMWATER INLETS.
4. DRAIN PIPE SHALL BE PLACED 1 PER LOT. DRAIN PIPE SHALL BE EXTENDED TO 1' BEHIND BACK OF SIDEWALK WHEN SIDEWALK IS INSTALLED BEFORE THE LOT IS CONNECTED TO THE DRAIN PIPE.
5. ADD 2" WIDE SHELF, 4" BELOW TOP OF CURB WHEN CURB IS PLACED ADJACENT TO SIDEWALK.
6. CRUSHED BASE ROCK SHALL BE COMPACTED TO 95% RELATIVE DENSITY PER ASTM D1557.
7. WHEN A DRIVEWAY IS PLACED WHERE THERE IS AN EXISTING MONOLITHIC CURB MAKE A VERTICAL SAWCUT AT THE FACE OF CURB. REPLACE BACK PART OF CURB AND ADD DRIVEWAY WITH ONE CONTIGUOUS POUR.
8. WHEN PLACING ASPHALT ADJACENT TO CURB A MINIMUM 2-FOOT WIDTH IS REQUIRED FOR COMPACTION OF BASE ROCK AND ASPHALT.

NTS

CITY OF
GRESHAM

MONOLITHIC CURB AND GUTTER

PWS VERSION: JULY 2026

DRAWN	KRB
REV. DATE	OCT 2025
APPR.	
DETAIL NO.	620

FILENAME: y:\inter-departmental\development engineering projects\public works standards\2.0 pws revision copy\details\cad - all\600_transportation\621.dwg, Plotted 4/20/2026 11:17 AM, By: Anthony Dollowitch, ANSI FULL BLEED A (8.50 X 11.00 INCHES)

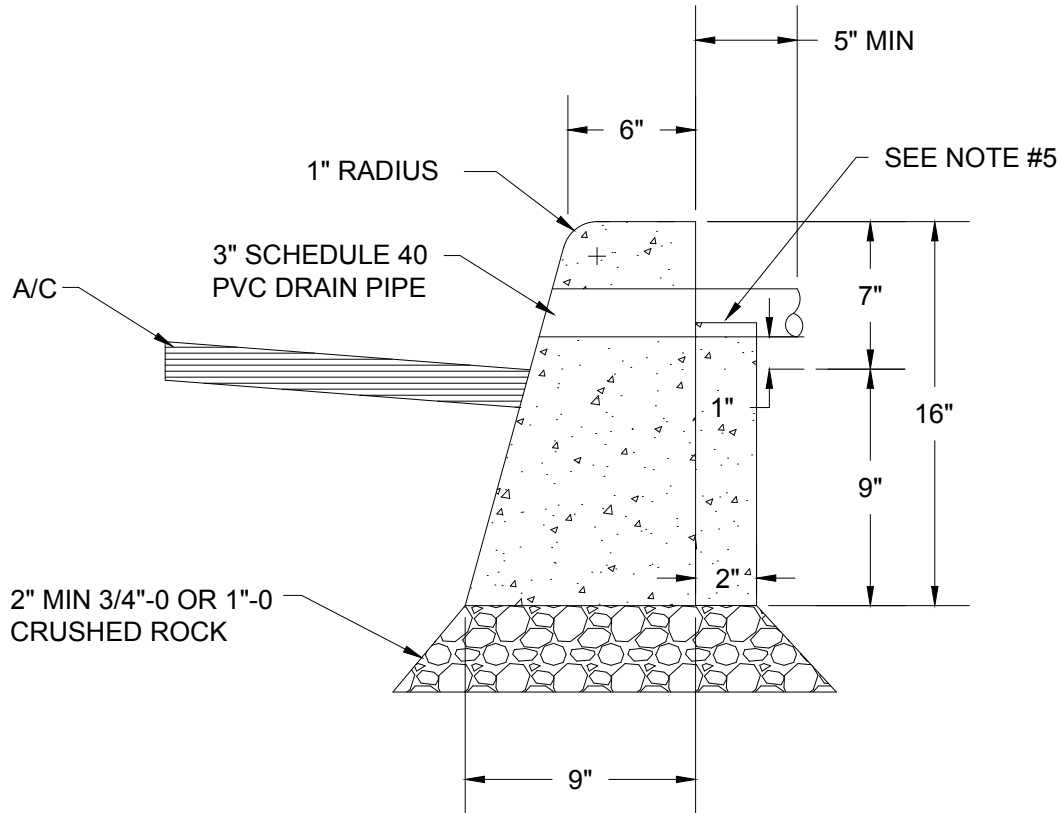

NOTES:

1. PCC SHALL BE 4,000 PSI STRENGTH AT 28 DAYS.
2. CONTRACTION JOINTS SHALL BE PLACED AT 15' MAX. SPACING.
3. CURB EXPOSURE SHALL BE 9" AT ALL STORMWATER INLETS.
4. DRAIN PIPE SHALL BE PLACED 1 PER LOT. DRAIN PIPE SHALL BE EXTENDED TO 1' BEHIND BACK OF WALK WHERE SIDEWALK IS INSTALLED BEFORE THE LOT IS CONNECTED TO THE DRAIN PIPE.
5. ADD 2" WIDE SHELF, 4" FROM TOP OF CURB, WHEN CURB IS PLACED ADJACENT TO SIDEWALK.
6. CRUSHED BASE ROCK SHALL BE COMPACTED TO 95% RELATIVE DENSITY PER ASTM D1557.
7. TYPE 'C' CURB SHALL ONLY BE INSTALLED WHERE REQUIRED TO MATCH EXISTING CURB TYPE.
8. WHEN PLACING ASPHALT ADJACENT TO CURB A MINIMUM 2-FOOT WIDTH IS REQUIRED FOR COMPACTION OF BASE ROCK AND ASPHALT.

NTS

CITY OF GRESHAM

TYPE 'C' CURB

PWS VERSION: JULY 2026

DRAWN	KRB
REV. DATE	OCT 2025
APPR.	
DETAIL NO.	621

FILENAME: y:\inter-departmental\development engineering projects\public works standards\2.0 pws revision copy\details\cad - all\600_transportation\622.dwg, Plotted: 4/20/2026 11:17 AM, By: Anthony Dollowitch, ANSI FULL BLEED A (8.50 X 11.00 INCHES)

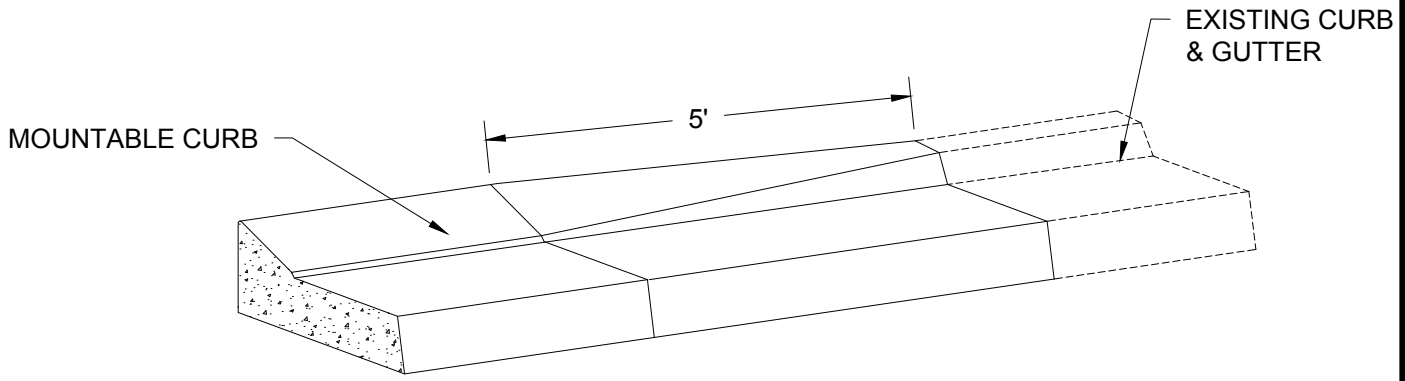
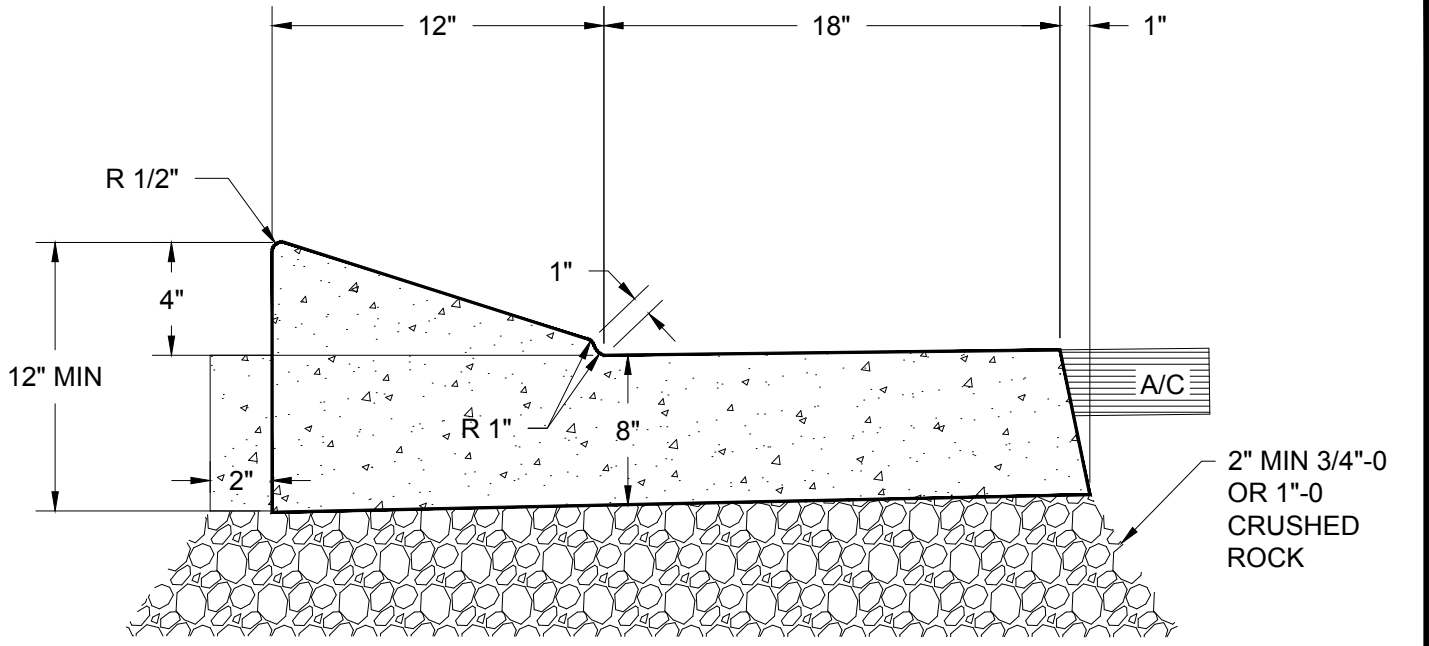

TRANSITION DETAIL

NOTES:

1. TO BE USED FOR HIGH DENSITY RESIDENTIAL DEVELOPMENT WITH CITY APPROVAL.
2. PCC SHALL BE 4,000 PSI STRENGTH AT 28 DAYS.
3. CONTRACTION JOINTS SHALL BE PLACED AT 15' MAX. SPACING.
4. ADD 2" WIDE SHELF, 4" BELOW TOP OF CURB WHEN CURB IS PLACED ADJACENT TO SIDEWALK.
5. CRUSHED BASE ROCK SHALL BE COMPACTED TO 95% RELATIVE DENSITY PER ASTM D1557.
6. ROOF DRAINS SHALL DRAIN DIRECTLY TO DRAINAGE CATCH BASINS.
7. WHEN PLACING ASPHALT ADJACENT TO CURB A MINIMUM 2-FOOT WIDTH IS REQUIRED FOR COMPACTION OF BASE ROCK AND ASPHALT.

NTS

	<p>MOUNTABLE CURB</p> <p>PWS VERSION: JULY 2026</p>	<p>DRAWN CM</p>
		<p>REV. DATE OCT 2025</p>
		<p>APPR.</p>
		<p>DETAIL NO. 622</p>

FILENAME: y:\inter-departmental\development engineering projects\public works standards\2.0 pws revision copy\details\cad - all\600_transportation\623.dwg, Plotted 4/20/2026 11:18 AM, By: Anthony Dollowitch, ANSI FULL BLEED A (8.50 X 11.00 INCHES)

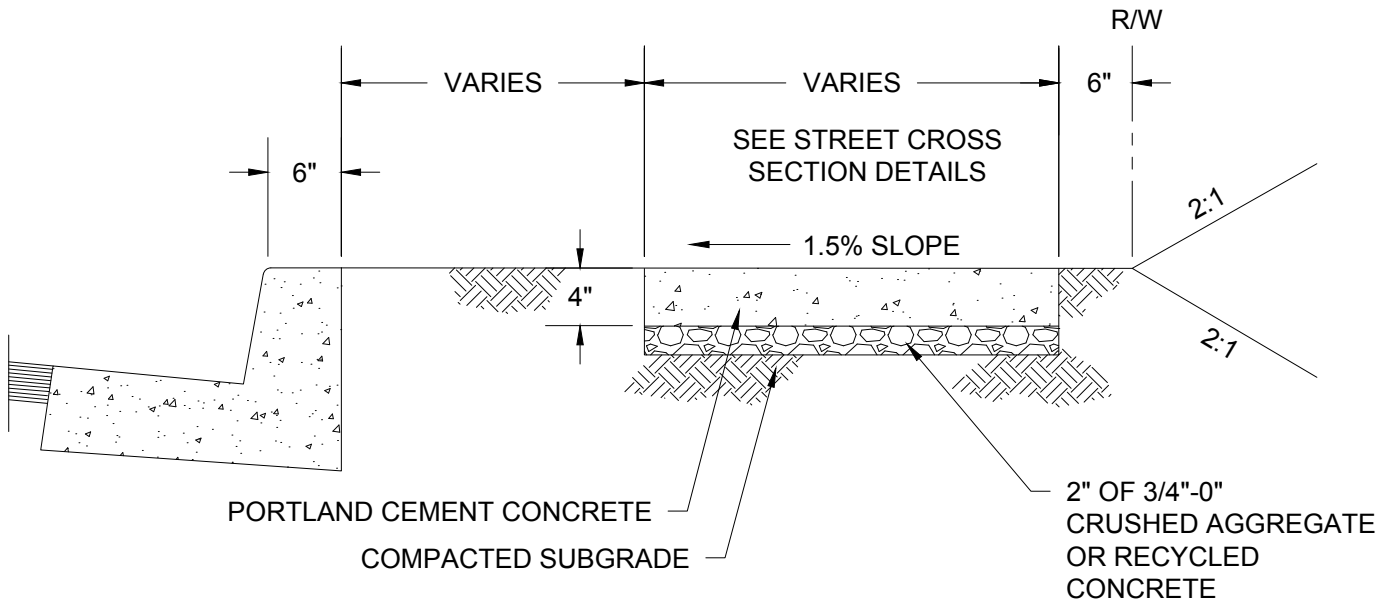

NOTES:

1. LOCATION AND WIDTH OF SIDEWALK WILL VARY DEPENDING UPON FUNCTIONAL CLASSIFICATION OF THE STREET. SEE TYPICAL STREET SECTION DETAILS.
2. PCC SHALL BE 4,000 PSI STRENGTH AT 28 DAYS.
3. CONTRACTION JOINTS SHALL BE PLACED AT ALL CHANGES OF DIRECTION, POINTS OF CURVATURE, ALIGNED WITH CURB CONTRACTION AND EXPANSION JOINTS WHEN SIDEWALK IS ADJACENT TO CURB, AND AT 15' (MAX) INTERVALS. JOINTS SHALL BE 1/8" TO 1/4" WIDE AND A MINIMUM DEPTH OF 1/3 THE THICKNESS OF THE CONCRETE.
4. ALL EDGES AND JOINTS SHALL BE TOOLED TO 1/2-INCH RADIUS PRIOR TO APPLYING A BROOM FINISH.
5. USE THIS DETAIL FOR MULTI USE PATH SECTIONS ADJACENT TO ROADWAYS.

CITY OF GRESHAM

TYPICAL SIDEWALK



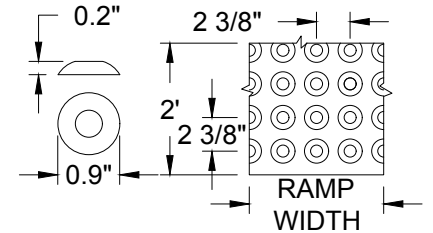
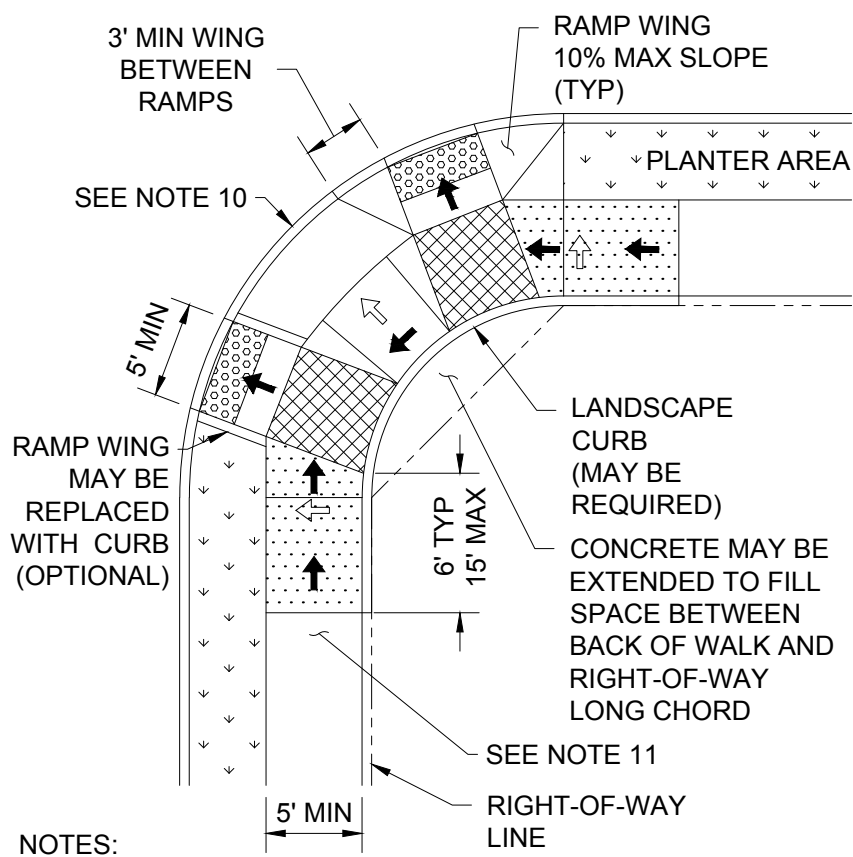

PWS VERSION: JULY 2026

DRAWN	AAD
REV. DATE	JULY 2025
APPR.	
DETAIL NO.	623

FILENAME: y:\inter-departmental\development_engineering\projects\public works standards\2.0 pws revision copy\details\cad - all\600_transportation\624.dwg, Plotted: 4/20/2026 11:18 AM, By: Anthony Dollowitch, ANSI FULL BLEED A (8.50 X 11.00 INCHES)



DETECTABLE WARNING SURFACE

-  GRADE TRANSITION RAMP
-  1.5% DESIGN GRADE MAXIMUM FOR CONSTRUCTION TOLERANCE, 2.0% MAX SLOPE FINISH GRADE.
-  7.5% DESIGN GRADE MAXIMUM FOR CONSTRUCTION TOLERANCE, 8.33% MAX SLOPE FINISH GRADE.
-  TRUNCATED DOME DETECTABLE WARNING SURFACE. SEE DETAIL THIS SHEET.
-  MINIMUM 60" x 60" LEVEL LANDING AREA. USE 1.5% DESIGN GRADE MAX. IN ALL DIRECTIONS FOR CONSTRUCTION TOLERANCE, 2% MAX. SLOPE FINISH GRADE.

NOTES:

1. SIDEWALK RAMP DETAILS ARE BASED ON U.S. DOT REQUIREMENTS. RAMPS MUST BE ADA COMPLIANT.
2. SIDEWALK RAMP SLOPES SHOWN ARE RELATIVE TO THE TRUE LEVEL HORIZON (ZERO BUBBLE). SIDE FLARE SLOPES SHALL BE 10% MAXIMUM.
3. TWO SIDEWALK RAMPS PER CORNER ARE REQUIRED AT ALL NEW INTERSECTIONS UNLESS IT IS TECHNICALLY INFEASIBLE. RAMPS SHALL BE LOCATED WITHIN THE CROSSWALK AND AS NEAR THE CONTINUOUS PEDESTRIAN ACCESS ROUTE AS PRACTICAL.
4. PLACE TRUNCATED DOME DETECTABLE WARNING TEXTURE IN THE LOWER 2 FEET OF THROAT OF RAMP ONLY. ARRANGE DOMES USING IN-LINE-PATTERN ONLY. COLOR OF TEXTURE TO BE BRICK RED.
5. SIDEWALK RAMPS SHALL BE FORMED AND Poured SEPARATE FROM SIDEWALK AND LANDINGS. COLD JOINTS SHALL BE KEYED OR DOWELED. EDGES OF THE ACCESSIBLE ROUTE SHALL BE Poured AGAINST RIGID FORMS OR CURED CONCRETE TO ENSURE COMPLIANCE WITH ORS 447.310 AND AMERICANS WITH DISABILITIES ACT.
6. PLACE AND COMPACT MIN. 2" OF 3/4"-0 CRUSHED ROCK BENEATH ALL CONCRETE SURFACES.
7. PROVIDE MINIMUM 1 FOOT CLEAR OF VERTICAL OBSTRUCTIONS INCLUDING CURBS ADJACENT TO 60" x 48" LEVEL LANDINGS.
8. INSTALL LANDSCAPE CURB AND/OR PLANTER AREA CURBS AS NEEDED.
9. THE RUNNING SLOPE OF A GRADE TRANSITION RAMP SHALL BE 7.5% MAXIMUM, BUT IS NOT REQUIRED TO EXCEED 15' IN LENGTH MEASURED FROM THE LEVEL LANDING AREA. LENGTH SHALL BE MEASURED ALONG THE BACK OF THE SIDEWALK.
10. THERE SHALL BE 1' MINIMUM WIDTH OF 3" MINIMUM CURB EXPOSURE BETWEEN RAMP WINGS.
11. INSTALL TRANSITION PANEL (5' MIN) FOR CROSS SLOPE TO TRANSITION BACK TO EXISTING SIDEWALK, IF NECESSARY.

NTS

CITY OF GRESHAM

SIDEWALK RAMP

PWS VERSION: JULY 2026

DRAWN	AAD
REV. DATE	AUG 2025
APPR.	
DETAIL NO.	624

FILENAME: y:\inter-departmental\development_engineering_projects\public_works_standards\2.0_pws_revision_copy\details\cad - all\600_transportation\625.dwg. Plotted 4/20/2026 11:18 AM, By: Anthony Dollowitch, ANSI FULL BLEED A (8.50 X 11.00 INCHES)

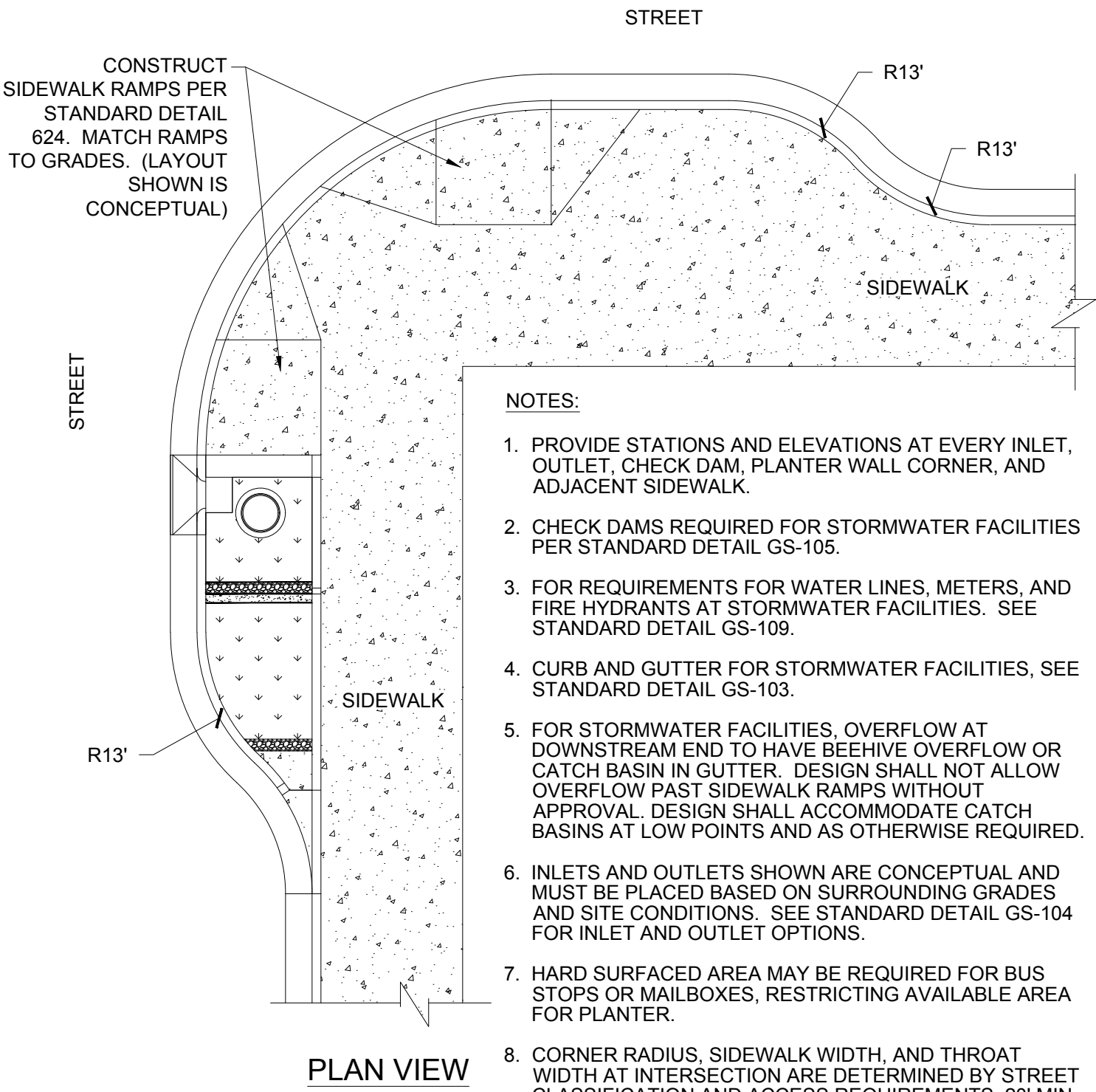

NOTES:

1. PROVIDE STATIONS AND ELEVATIONS AT EVERY INLET, OUTLET, CHECK DAM, PLANTER WALL CORNER, AND ADJACENT SIDEWALK.
2. CHECK DAMS REQUIRED FOR STORMWATER FACILITIES PER STANDARD DETAIL GS-105.
3. FOR REQUIREMENTS FOR WATER LINES, METERS, AND FIRE HYDRANTS AT STORMWATER FACILITIES. SEE STANDARD DETAIL GS-109.
4. CURB AND GUTTER FOR STORMWATER FACILITIES, SEE STANDARD DETAIL GS-103.
5. FOR STORMWATER FACILITIES, OVERFLOW AT DOWNSTREAM END TO HAVE BEEHIVE OVERFLOW OR CATCH BASIN IN GUTTER. DESIGN SHALL NOT ALLOW OVERFLOW PAST SIDEWALK RAMPS WITHOUT APPROVAL. DESIGN SHALL ACCOMMODATE CATCH BASINS AT LOW POINTS AND AS OTHERWISE REQUIRED.
6. INLETS AND OUTLETS SHOWN ARE CONCEPTUAL AND MUST BE PLACED BASED ON SURROUNDING GRADES AND SITE CONDITIONS. SEE STANDARD DETAIL GS-104 FOR INLET AND OUTLET OPTIONS.
7. HARD SURFACED AREA MAY BE REQUIRED FOR BUS STOPS OR MAILBOXES, RESTRICTING AVAILABLE AREA FOR PLANTER.
8. CORNER RADIUS, SIDEWALK WIDTH, AND THROAT WIDTH AT INTERSECTION ARE DETERMINED BY STREET CLASSIFICATION AND ACCESS REQUIREMENTS. 20' MIN. CURB RETURN RADIUS. 24' MIN. THROAT WIDTH.
9. ADA RAMPS AND SIDEWALK LEADING TO ADA RAMPS THAT, DUE TO STREET GRADE, CANNOT DRAIN TO A STORMWATER FACILITY SHALL DRAIN TO THE STREET.
10. CORNER CURB EXTENSIONS ARE REQUIRED WHERE ON-STREET PARKING IS ALLOWED IN THE DOWNTOWN PLAN DISTRICT.

NTS

<p>CITY OF GRESHAM</p>	<p>CORNER CURB EXTENSION</p>	<p>DRAWN DRO</p>
		<p>REV. DATE OCT 2025</p>
		<p>APPR.</p>
		<p>DETAIL NO. 625</p>
<p>PWS VERSION: JULY 2026</p>		

MULTI-USE PATH AND CONNECTOR PATH

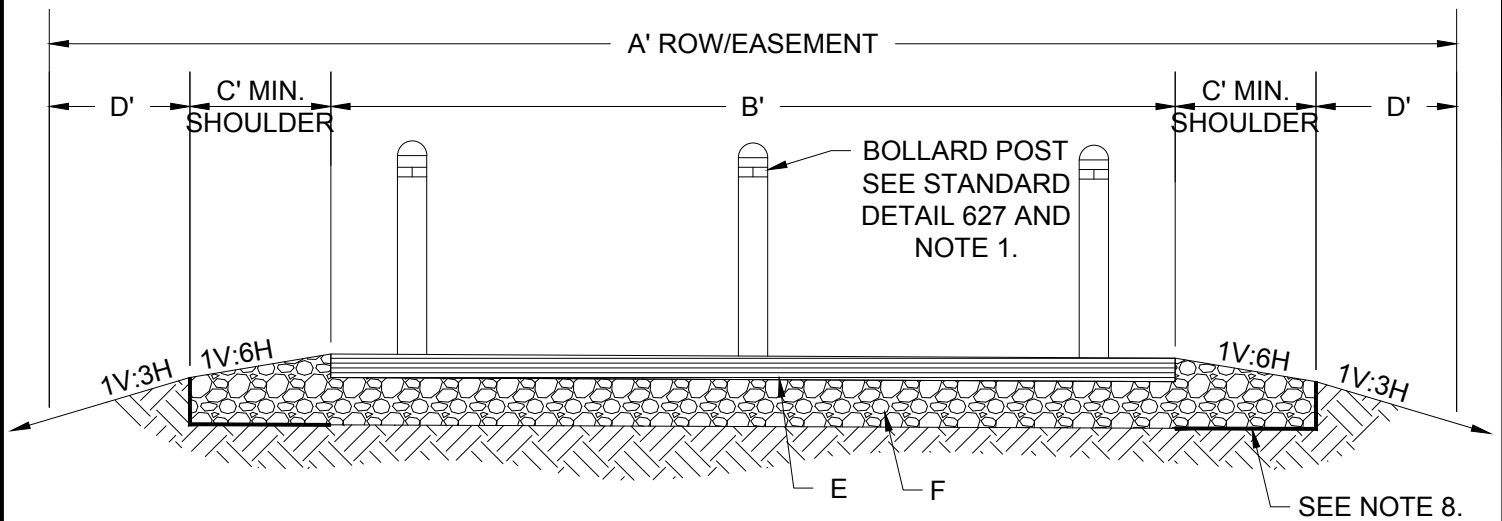

	MULTI-USE PATH	CONNECTOR PATH
A	20'	15'
B	14'	10'
C	2'	1.5'
D	1'	1'
E	4" OF 1/2" DENSE GRADED, LEVEL 2 AC IN TWO LIFTS*	4" PORTLAND CEMENT CONCRETE
F	8" OF 1"-0 CRUSHED AGGREGATE	2" OF 3/4"-0 CRUSHED AGGREGATE

* IF PATH RUNS ALONG A ROADWAY, USE PCC AND REFER TO STANDARD DETAIL 623 FOR SECTION.

NOTES:

- BOLLARDS SHALL BE PLACED WHERE PATHS INTERSECT ROADWAYS, AND HAVE A MINIMUM 20' SETBACK FROM FACE OF CURB. THERE SHALL BE A MINIMUM OF 6 FEET CLEARANCE BETWEEN BOLLARDS, MAINTAINING EQUAL SPACING FROM EACH SIDE OF THE ROW/EASEMENT. NUMBER OF BOLLARDS VARIES BASED ON WIDTH OF PATHWAY, MINIMUM 2 BOLLARDS.
- WHERE PATHS CONTINUE ACROSS STREETS, ADA RAMPS SHALL BE REQUIRED.
- MINIMUM VERTICAL CLEARANCE SHALL BE 10'.
- MAXIMUM CROSS SLOPE SHALL BE 1.5%.
- MAXIMUM PATH GRADE IS 5%, UNLESS ADJACENT TO A ROADWAY. IF PATH IS ADJACENT TO A ROADWAY IT SHALL MATCH ROAD GRADE.
- SUBGRADE AND BASEROCK SHALL BE COMPACTED TO 95% RELATIVE DENSITY PER ASTM D1557. ASPHALT SURFACES SHALL BE COMPACTED TO 91% OF RICE DENSITY.
- PATHS MUST MEET THE DESIGN REQUIREMENTS OF AASHTO GUIDE FOR THE DEVELOPMENT OF BICYCLE FACILITIES AND THE GRESHAM COMMUNITY DEVELOPMENT CODE.
- SHOULDERS SHALL HAVE SUBGRADE GEOTEXTILE PLACED ON THE SUBGRADE PRIOR TO ROCK PLACEMENT.

CITY OF
GRESHAM

PATHS

PWS VERSION: JULY 2026

DRAWN AAD

REV. DATE AUG 2025

APPR.

DETAIL NO. 626A

FILENAME: y:\inter-departmental\development engineering projects\public works standards\2.0 pws revision copy\details\cad - all\600_transportation\626b.dwg, Plotted 4/20/2026 11:18 AM, By: Anthony Dollowitch, ANSI FULL BLEED A (8.50 X 11.00 INCHES)

TRAILS

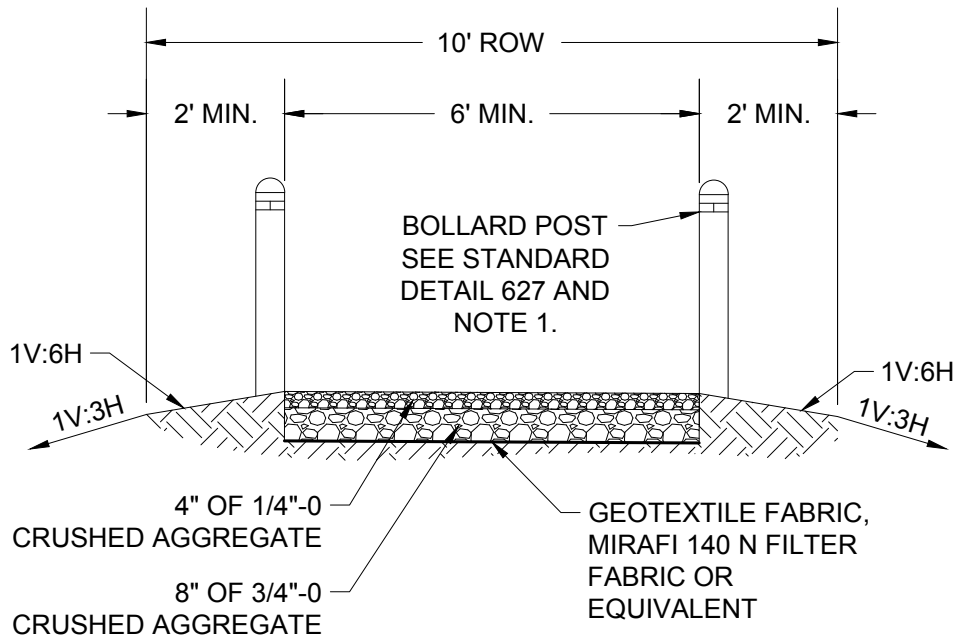

NOTES:

1. BOLLARDS SHALL BE PLACED WHERE TRAILS INTERSECT ROADWAYS, AND HAVE A MINIMUM 20' SETBACK FROM FACE OF CURB. THERE SHALL BE A MINIMUM OF 6 FEET CLEARANCE BETWEEN BOLLARDS, MAINTAINING EQUAL SPACING FROM EACH SIDE OF THE ROW/EASEMENT. NUMBER OF BOLLARDS VARIES BASED ON WIDTH OF TRAIL, MINIMUM 2 BOLLARDS.
2. WHERE TRAILS CONTINUE ACROSS STREETS, ADA RAMPS SHALL BE REQUIRED.
3. MINIMUM VERTICAL CLEARANCE SHALL BE 10'.
4. MAXIMUM CROSS SLOPE SHALL BE 1.5%.
5. MAXIMUM TRAIL GRADE IS 10%, UNLESS ADJACENT TO A ROADWAY. IF TRAIL IS ADJACENT TO A ROADWAY IT SHALL MATCH ROAD GRADE.
6. SUBGRADE AND BASEROCK SHALL BE COMPACTED TO 95% RELATIVE DENSITY PER ASTM D1557.

	<h2 style="margin: 0;">TRAILS</h2>	DRAWN AAD
		REV. DATE AUG 2025
		APPR.
		DETAIL NO. 626B
PWS VERSION: JULY 2026		

FILENAME: y:\inter-departmental\development engineering projects\public works standards\2.0 pws revision copy\details\cad - all\600_transportation\627.dwg, Plotted 4/20/2026 11:18 AM, By: Anthony Dollowitch, ANSI FULL BLEED A (8.50 X 11.00 INCHES)

3/8"-16x3/8" HEX SOCKET SET SCREW (TYP.)

INSTALLATION SEQUENCE

1. DIG FOOTING HOLE AND SET "POST FOOTING SLEEVE" PLUM AND SQUARE IN CONCRETE
2. INSERT "REMOVABLE BOLLARD INSERT" INTO METAL BOLLARD
3. TIGHTEN HEX SOCKET SET SCREWS.
4. SET THE "REMOVABLE BOLLARD INSERT" INTO THE "POST FOOTING SLEEVE"

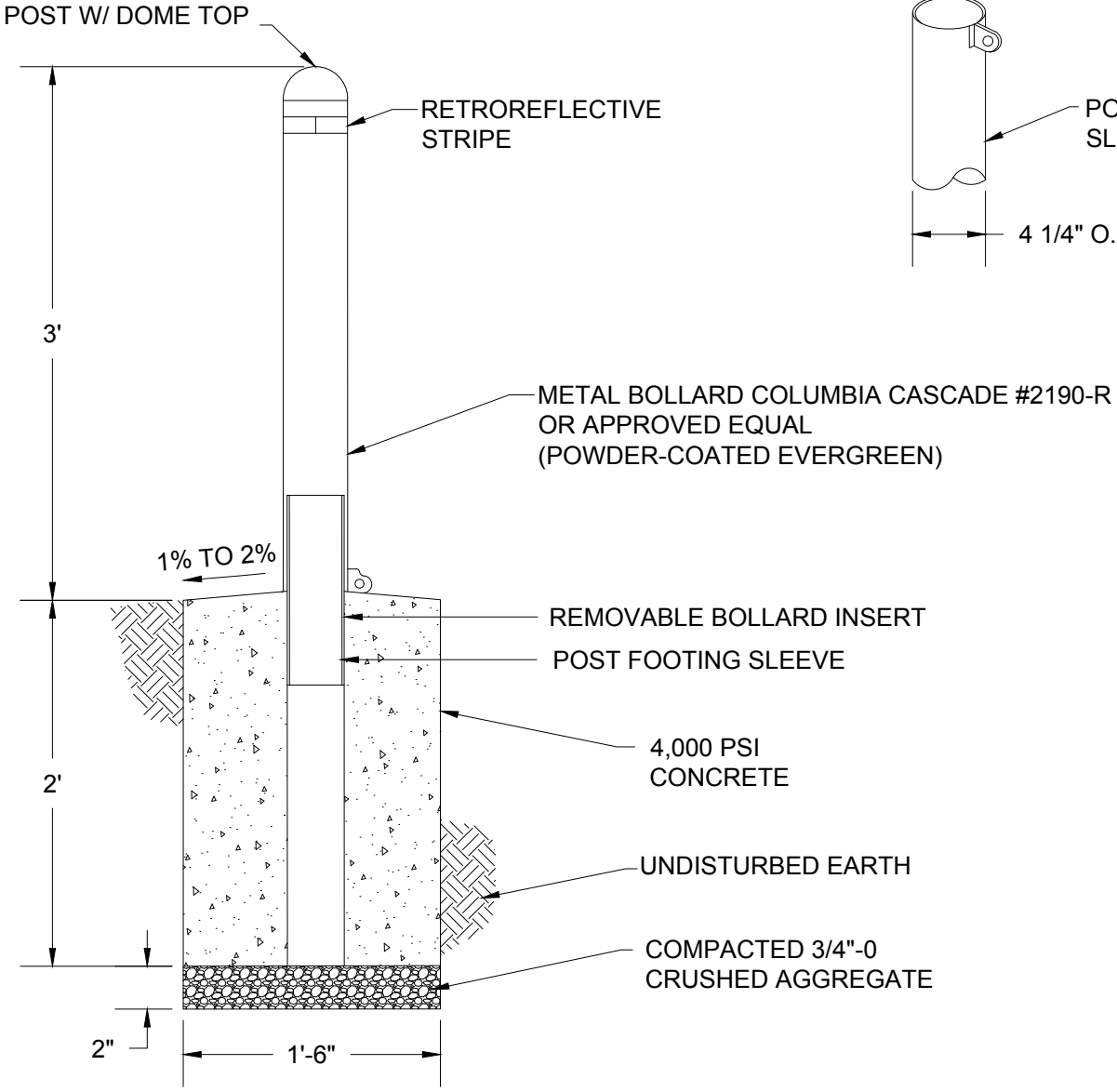
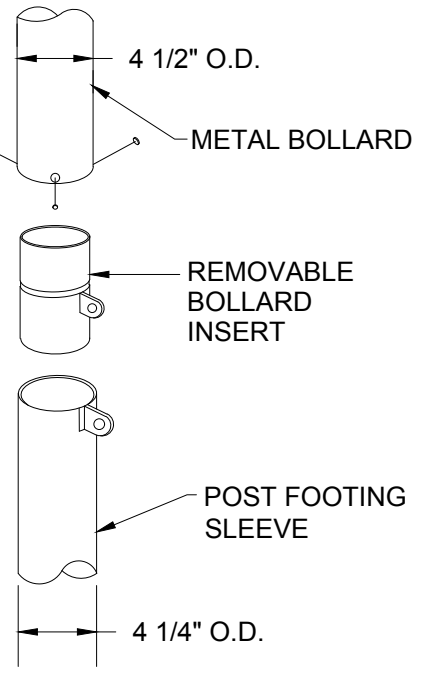

NOTES:

1. LOCK TAB TO BE ORIENTED OPPOSITE THE DIRECTION OF VEHICULAR ACCESS.

NTS

	<p>BOLLARD</p>	DRAWN CM
		REV. DATE MAR 2021
		APPR.
		DETAIL NO. 627
PWS VERSION: JULY 2026		

FILENAME: y:\inter-departmental\development engineering projects\public works standards\2.0 pws revision copy\details\cad - all\600_transportation\628.dwg, Plotted 4/20/2026 11:18 AM, By: Anthony Dollowitch, ANSI FULL BLEED A (8.50 X 11.00 INCHES)

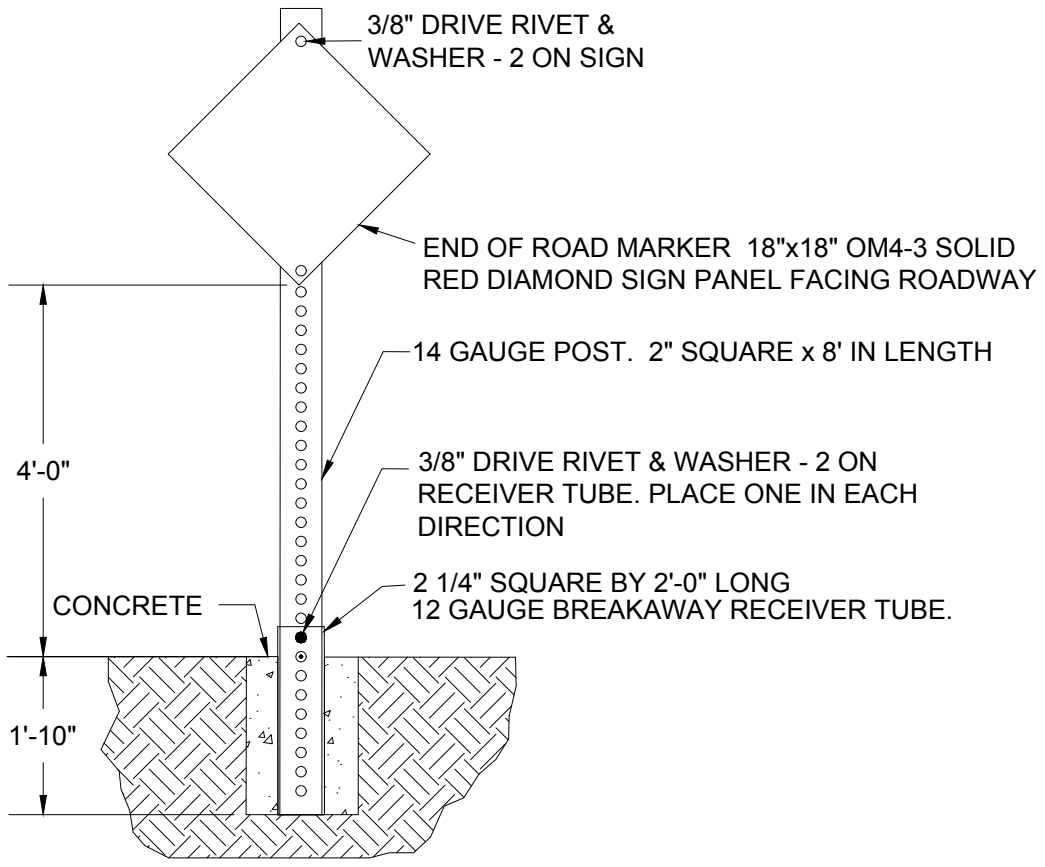
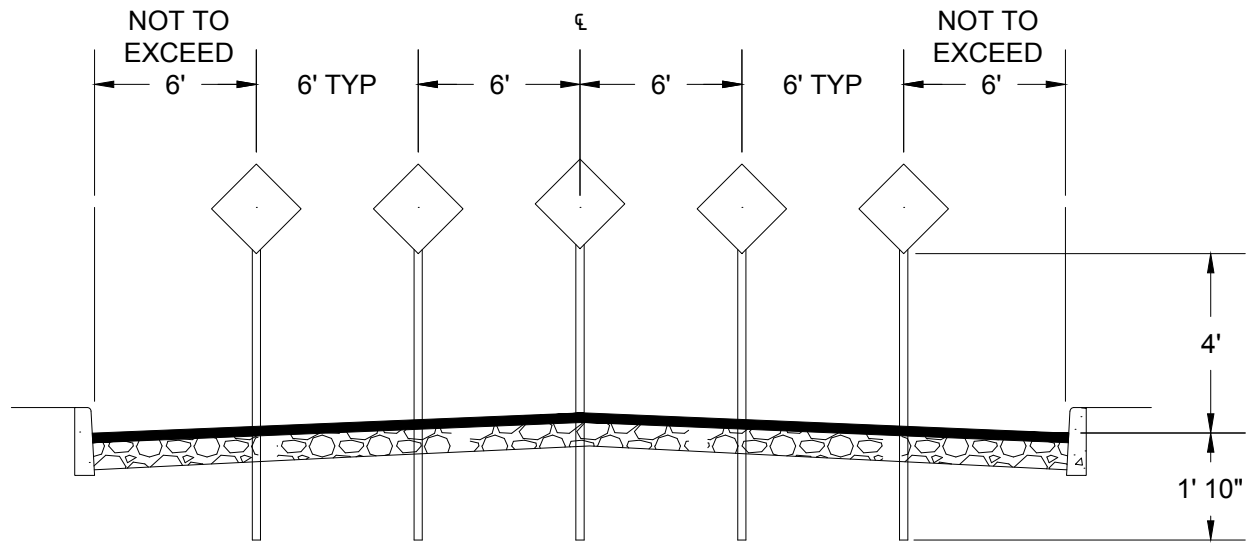

NOTES:

1. END OF ROAD MARKERS SHALL BE USED IN LIEU OF STREET BARRICADE WHERE NO DROP OFF HAZARD (SLOPES GREATER THAN 3:1 OR 18" OR GREATER VERTICALLY) EXISTS.
2. RECEIVER TUBE SHALL BE COVERED BY DUCT TAPE ON ALL SIDES.
3. POST SHALL BE COATED WITH ANTI-SEIZE ON THE BOTTOM 2'.

NTS



END OF ROAD MARKERS

PWS VERSION: JULY 2026

DRAWN	CM
REV. DATE	JAN 2019
APPR.	
DETAIL NO.	628

FILENAME: y:\inter-departmental\development engineering projects\public works standards\2.0 pws revision copy\details\cad - all\600_transportation\629.dwg, Plotted 4/20/2026 11:18 AM, By: Anthony Dollovlitch, ANSI FULL BLEED A (8.50 X 11.00 INCHES)

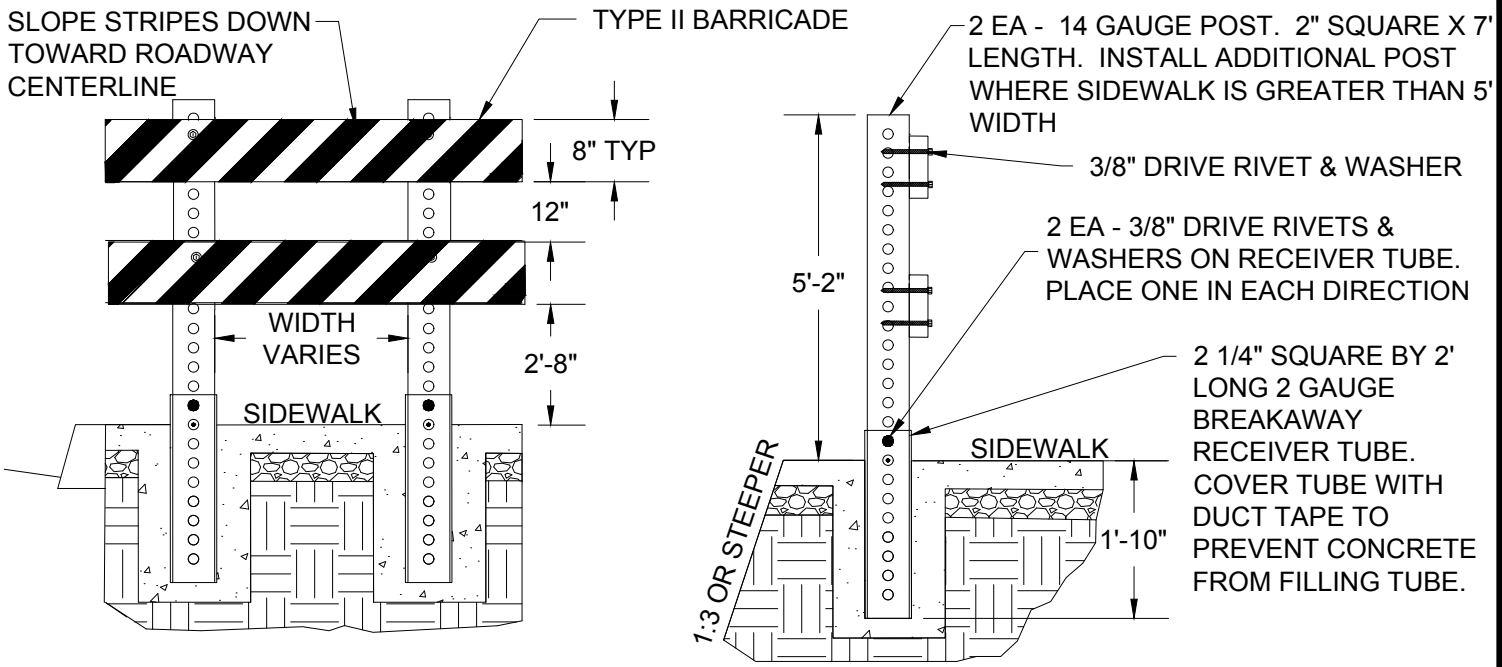

NOTES:

1. ASPHALT TRANSITION ADA RAMP MAY BE USED INSTEAD OF BARRICADES OR SIGNAGE.
2. TYPE II BARRICADE TO BE USED WHERE SIDEWALK DROP-OFF EXCEEDS 18" VERTICAL WITH A SLOPE OF 1:3 OR GREATER.
3. STRIPING FOR TYPE II BARRICADE: TYPE IV RETRO-REFLECTIVE SHEET WITH ALTERNATING 6" RED AND WHITE STRIPES PLACED AT A 45 DEGREE ANGLE SHALL BE PLACED ON A 7 1/4" X 48" MIN. .080 GAGE ALUMINUM PANEL. PANEL TO BE ATTACHED TO 2 X 8 PRESSURE TREATED BOARD WITH 6 #12 X 1-1/4" SELF-TAPPING VANDAL RESISTANT SCREWS.
4. CENTER BARRICADE ON SIDEWALK 6" BEYOND END OF SIDEWALK. WHEN POSTS MUST BE SET IN THE SIDEWALK, THE SIDEWALK MUST HAVE A TOOLED CONTRACTION JOINT INSTALLED 12" IN FRONT OF POSTS.

	<h2 style="margin: 0;">END OF SIDEWALK MARKER</h2>	DRAWN CM
		REV. DATE AUG 2025
		APPR.
		DETAIL NO. 629
PWS VERSION: JULY 2026		

FILENAME: y:\inter-departmental\development engineering projects\public works standards\2.0 pws revision copy\details\cad - all\600_transportation\630.dwg. Plotted 4/20/2026 11:18 AM, By: Anthony Dollowitch, ANSI FULL BLEED A (8.50 X 11.00 INCHES)

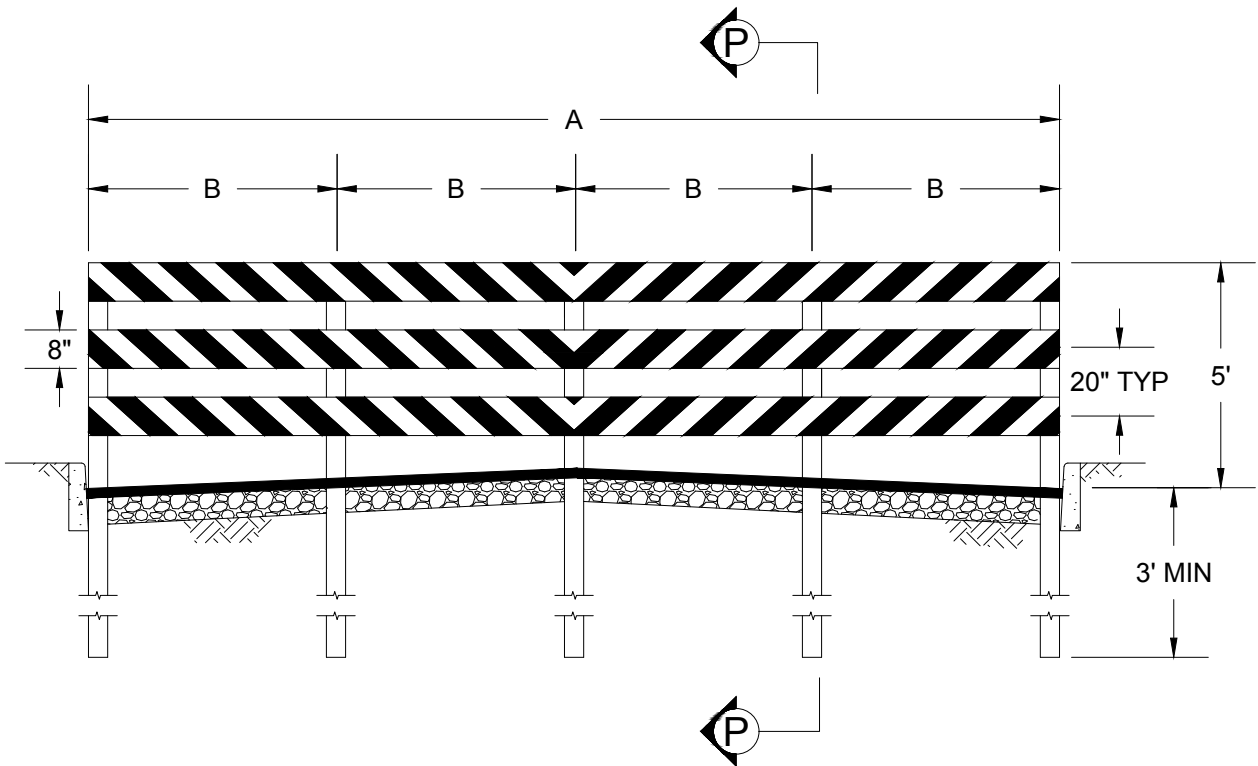

A*	B
40'	10'
36'	9'
32'	8'

* FOR STREETS WITH NONSTANDARD PAVEMENT WIDTHS, EQUAL SPACING BETWEEN POSTS SHALL BE MAINTAINED, NOT TO EXCEED 10', AND SHALL BE CENTERED ON STREET CENTERLINE.

NOTES:

1. 6" RED AND WHITE STRIPES AT A 45 DEGREE ANGLE SHALL BE RETRO-REFLECTIVE TYPE IV SHEETING.
2. PLACEMENT SHALL BE CONSISTENT WITH THE REQUIREMENTS OF THE MANUAL ON UNIFORM TRAFFIC CONTROL DEVICES.

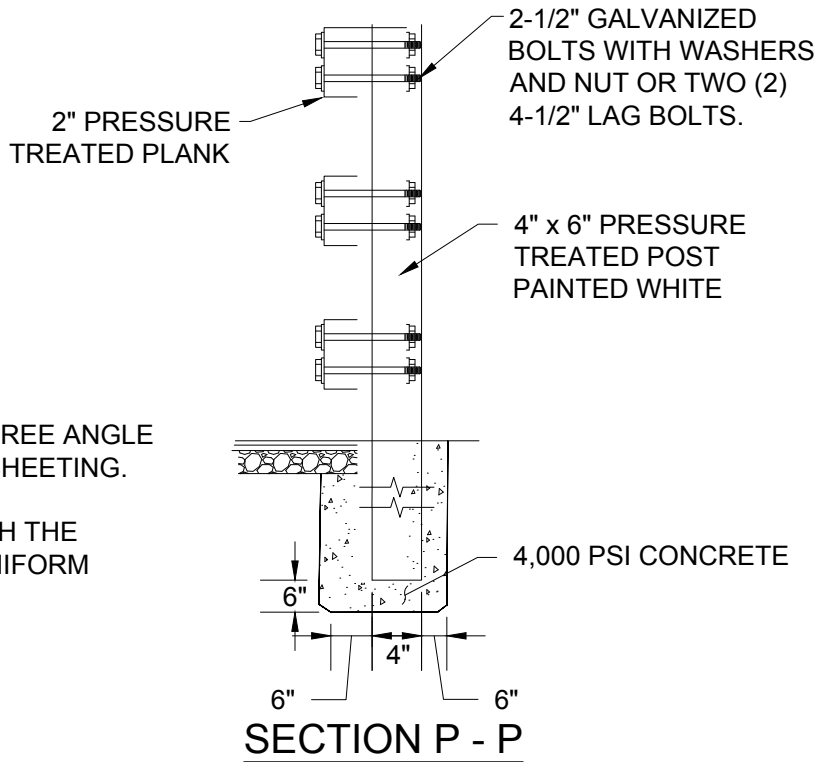

NTS

CITY OF GRESHAM

STREET BARRICADE

PWS VERSION: JULY 2026

DRAWN	CM
REV. DATE	MAR 2021
APPR.	
DETAIL NO.	630

FILENAME: y:\inter-departmental\development engineering projects\public works standards\2.0 pws revision copy\details\cad - all\600_transportation\631.dwg, Plotted 4/20/2026 11:18 AM, By: Anthony Dollowitch, ANSI FULL BLEED A (8.50 X 11.00 INCHES)

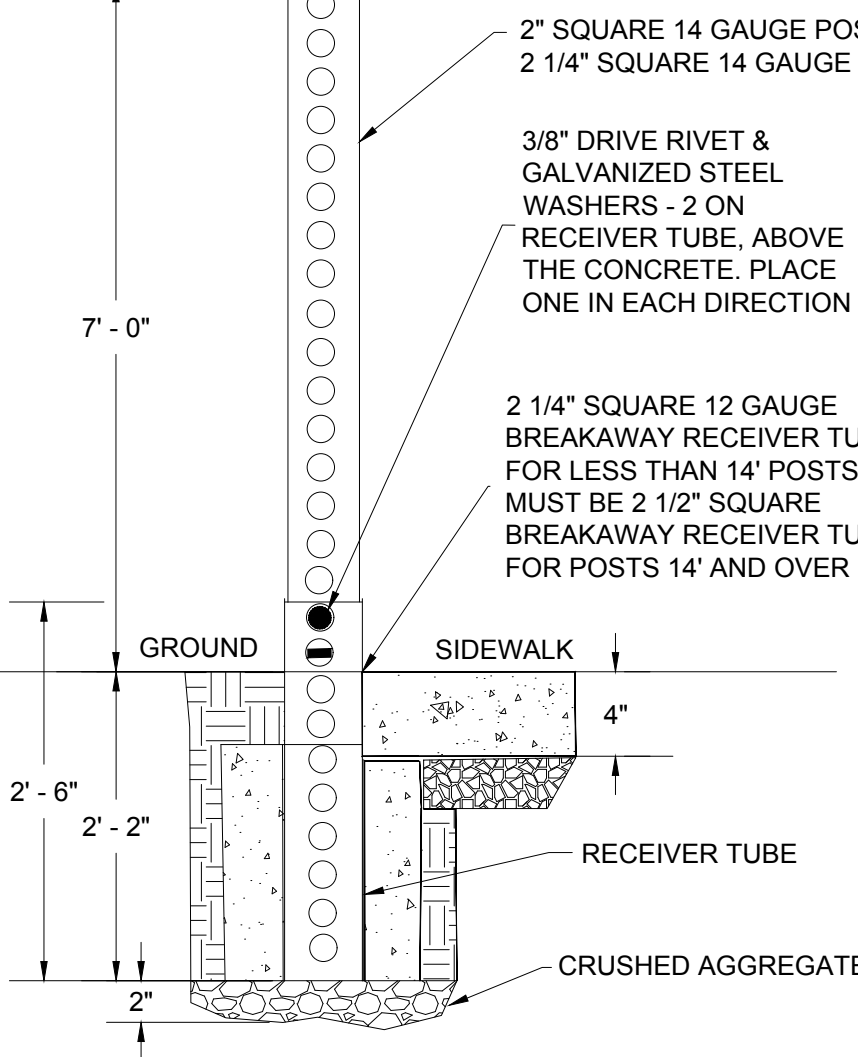
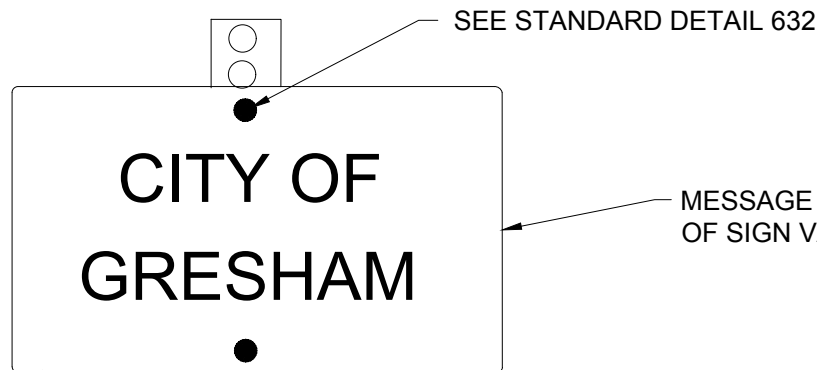

- NOTES:
- RECEIVER TUBE SHALL BE COVERED BY DUCT TAPE ON ALL SIDES.
 - RECEIVER TUBE SHALL BE SET IN 22" OF CONCRETE UNLESS IN SIDEWALK.
 - RECEIVER TUBES SET IN SIDEWALK SHALL HAVE 2 HOLES COMPLETELY ABOVE FINISHED SURFACE.
 - IF RECEIVER TUBE IS SET IN SIDEWALK IT SHALL BE 2'-2" DEEP & BACKFILLED WITH COMPACTED FILL, THEN CONCRETE FROM BOTTOM TO TOP OF WALK.
 - SIGN PLACEMENT IN SIDEWALK SHALL ALLOW FOR 5' CLEAR PASSAGE & EDGE OF SIGN SHALL BE 24" FROM FACE OF CURB.
 - POST SHALL BE COATED WITH ANTI-SEIZE ON THE SECTION FITTED INSIDE THE RECEIVER TUBE.

RECEIVER TUBES			
POST SIZE	GAUGE	ANCHOR SIZE	CONCRETE SET DEPTH
≤10'	12 GA	2 1/4" X 24"	22"
12'	12 GA	2 1/4" X 30"	28"
14'	12 GA	2 1/2" X 36"	34"
16'-18'	7 GA	2 1/2" X 36"	34"

NTS

	<h1>STANDARD SIGNPOST</h1>	DRAWN CM
		REV. DATE JAN 2019
		APPR.
		DETAIL NO. 631
PWS VERSION: JULY 2026		

FILENAME: y:\inter-departmental\development engineering projects\public works standards\2.0 pws revision copy\details\cad - all\600_transportation\632.dwg, Plotted 4/20/2026 11:18 AM, By: Anthony Dollowitch, ANSI FULL BLEED A (8.50 X 11.00 INCHES)

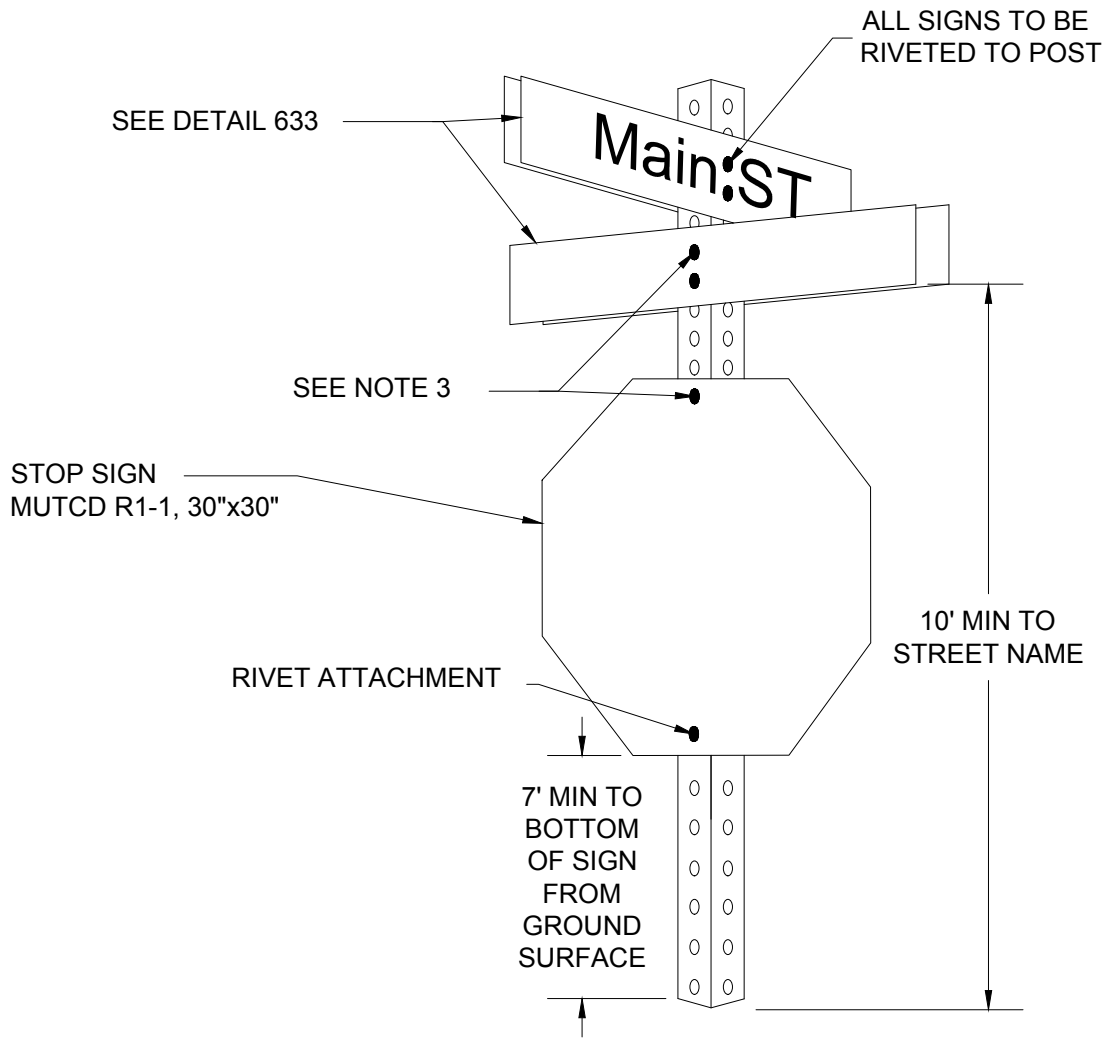

NOTES:

1. SEE DETAIL 631 FOR POST SIZING AND INSTALLATION GUIDELINES.
2. DIMENSIONS DEPICT TYPICAL STOP SIGN/STREET NAME SIGN INSTALLATION ON LOCAL STREETS. SIGNAGE ON HIGHER CLASSIFICATION ROAD, OR MORE COMPLEX CONFIGURATION, WILL BE AS DETERMINED BY ENGINEER.
3. INSTALL NYLON SPACERS WHERE REQUIRED TO PREVENT CONTACT BETWEEN STEEL AND ALUMINUM SURFACES.
4. PANELS SHALL BE RIVETED TO POST.

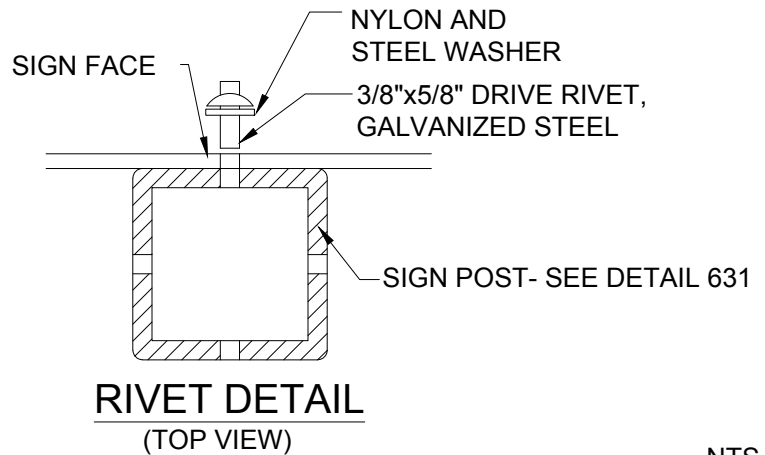

NTS

DRAWN	CM
REV. DATE	JAN 2019
APPR.	
DETAIL NO.	632

FILENAME: y:\inter-departmental\development engineering projects\public works standards\20 pws revision copy\details\cad - all\600_transportation\633.dwg, Plotted 4/20/2026 11:18 AM, By: Anthony Dollowitch, ANSI FULL BLEED A (8.50 X 11.00 INCHES)

DIMENSIONS FOR STREET NAME SIGNS

MOUNTING TYPE	STREET TYPE OR SPEED LIMIT	PANEL HEIGHT A	LETTER HEIGHT UPPERCASE B	PREFIX SUFFIX HEIGHT D	SPACE S	BORDER THICKNESS J	ARROW TAIL THICKNESS T	ARROW LENGTH L
POST	≤ 25 MPH	8"	4"	3"	2" MIN	NONE	-	5"
	PRIVATE (ALL)							
POST	>25 MPH ≤40 PH	12"	6"	4"	3"	3/8"	-	-
POST	>40 MPH	15"	8"	6"	4"	1/2"	-	-
OVERHEAD	ALL	21"	12"	9"	6"	1"	-	-
OVERHEAD STACKED LEGEND	ALL	30"	8"	5"	4"	1"	3"	12"

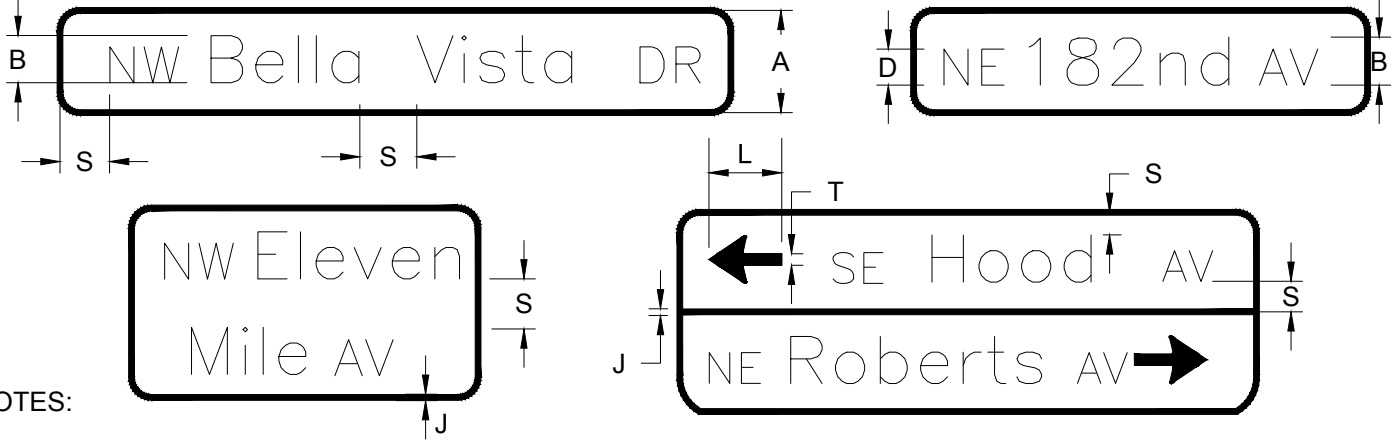

NOTES:

- SIGN PANELS SHALL BE 0.08" ALUMINUM FLAT BLADE WITH 1.5" RADIUS CORNERS. SIGNS OVER 36" IN WIDTH OR HEIGHT SHALL BE THICKNESS OF 0.100".
- SIGN FACE SHALL BE COVERED WITH 3M HIP REFLECTIVE SHEETING OR EQUIVALENT, GREEN BACKGROUND WITH WHITE LEGEND AND BORDER OVER 6" IN HEIGHT.
- AT INTERSECTIONS OF TWO-LANE ROADS, INSTALL MINIMUM OF ONE STREET NAME SIGN. ON INTERSECTIONS OF MULTI-LANE ROADS, INSTALL MINIMUM OF 2 SIGNS ON DIAGONAL CORNERS OF INTERSECTION.
- LEGENDS SHALL BE STANDARD ALPHABET SERIES C, UPPER AND LOWER CASE, PER STANDARD HIGHWAY SIGNS AND MARKINGS (SHS) CURRENT EDITION. LEGEND HEIGHT TO BE DICTATED BY HIGHEST CLASSIFICATION STREET AT INTERSECTION.
- IF PANEL WIDTH WOULD EXCEED 5' (OR 12' FOR OVERHEAD MAST ARM INSTALLATION) USE 2-LINE LEGEND.
- LEGEND SHALL BE APPROVED BY ENGINEER PRIOR TO FABRICATION. MINOR VARIATIONS IN SPACING DIMENSIONS MAY BE PERMITTED, PROVIDED LEGIBILITY IS MAINTAINED AND APPROVED.
- REFER TO MANUAL ON UNIFORM TRAFFIC CONTROL DEVICES (MUTCD) CURRENT EDITION FOR OTHER SIGNAGE REQUIREMENTS NOT COVERED IN THIS DETAIL

NTS



STREET NAME SIGNS

PWS VERSION: JULY 2026

DRAWN	CM
REV. DATE	JAN 2019
APPR.	
DETAIL NO.	633

FILENAME: y:\inter-departmental\development_engineering_projects\public_works_standards\2.0_pws_revision_copy\details\cad - all\600_transportation\635.dwg, Plotted 4/20/2026 11:18 AM, By: Anthony Dollowitch, ANSI FULL BLEED A (8.50 X 11.00 INCHES)

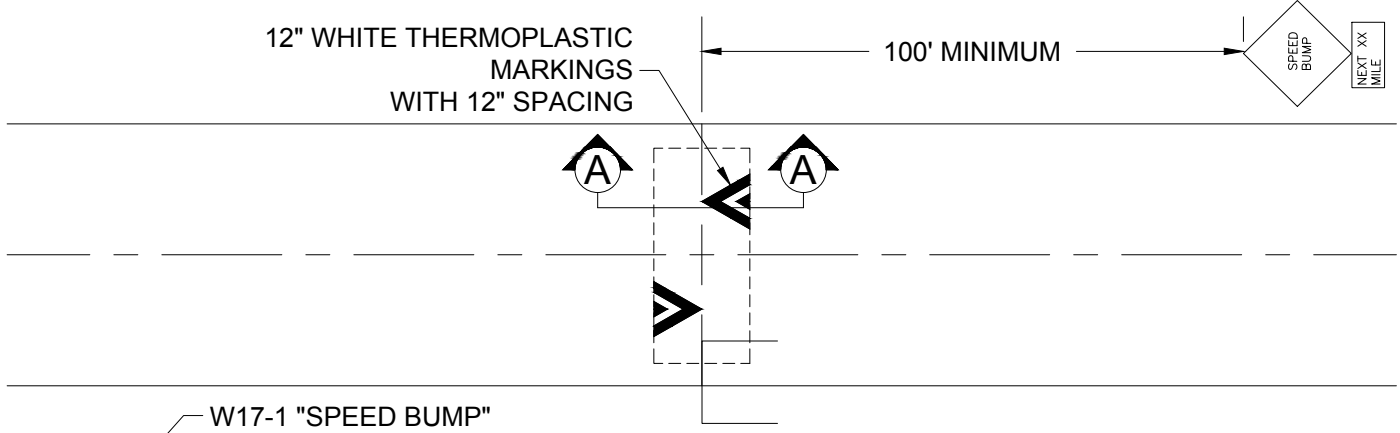

SIGNING AND STRIPING PLAN

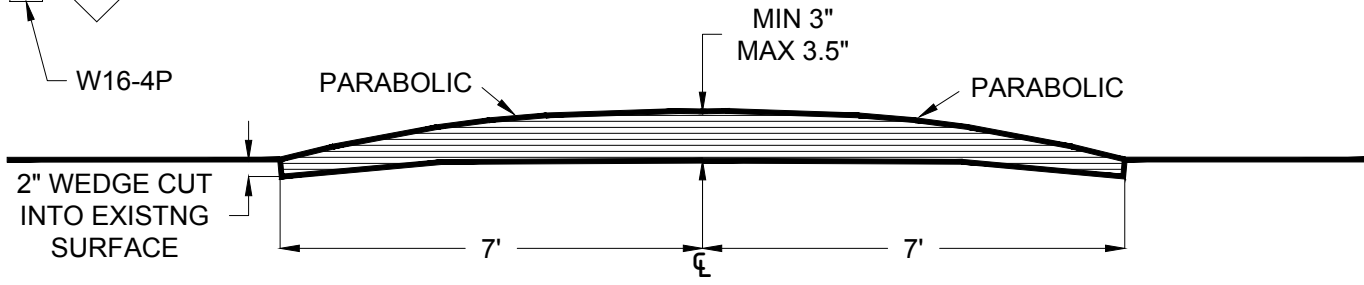

SECTION A-A 14' WIDE OPTION

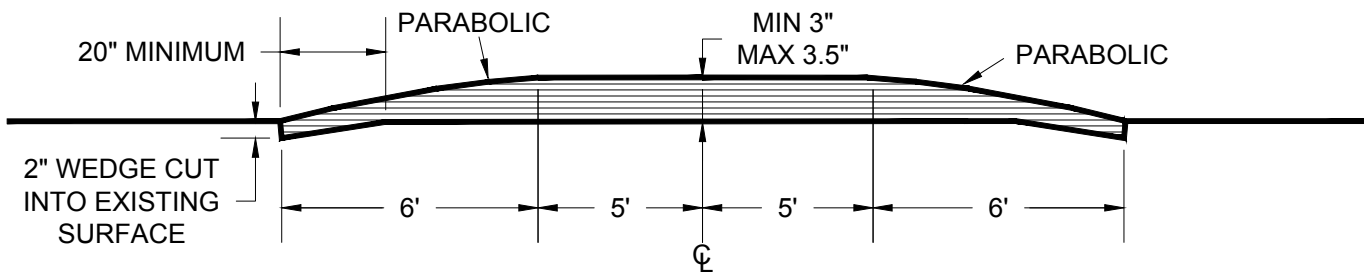

SECTION A-A 22' WIDE OPTION

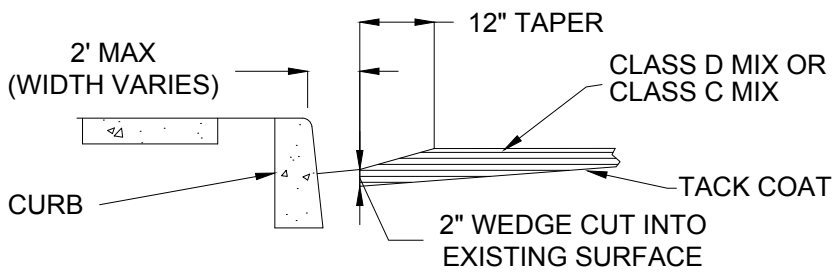

SECTION B-B

NOTES:

1. SPACING BETWEEN BUMPS SHALL BE BETWEEN 300 AND 600 FEET AS APPROVED BY THE CITY.
2. ASPHALT GRADING TOLERANCE FOR BUMPS SHOULDN'T VARY BY MORE THAN 0.5" HIGH OR .25" LOW FROM DIMENSIONS SHOWN.

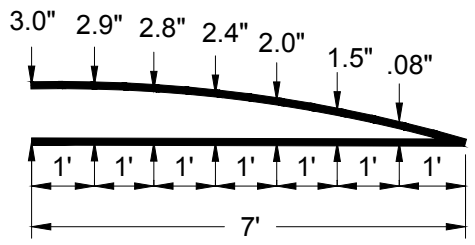
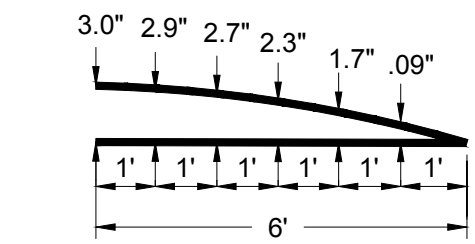

PARABOLIC GRADING DIAGRAMS NTS



SPEED BUMP

PWS VERSION: JULY 2026

DRAWN	DD
REV. DATE	JAN 2019
APPR.	
DETAIL NO.	635

FILENAME: y:\inter-departmental\development engineering projects\public works standards\2.0 pws revision copy\details\cad - all\600_transportation\636.dwg, Plotted 4/20/2026 11:18 AM, By: Anthony Dollowitch, ANSI FULL BLEED A (8.50 X 11.00 INCHES)

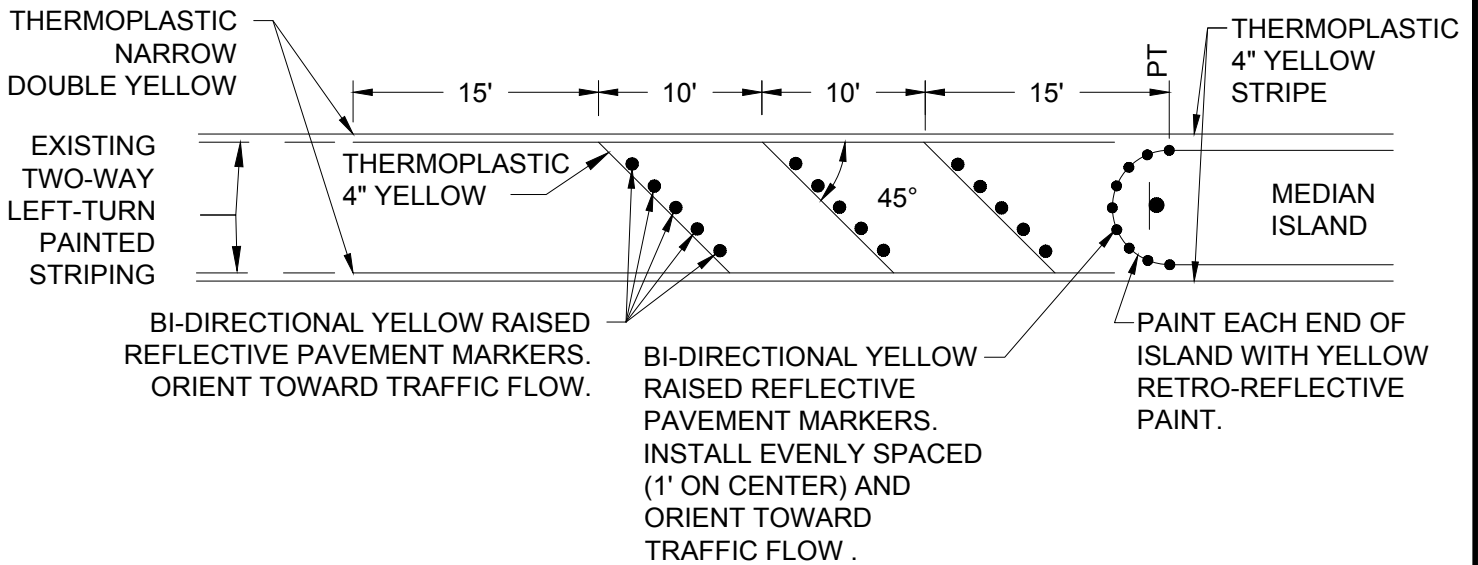

BI-DIRECTIONAL YELLOW RAISED REFLECTIVE PAVEMENT MARKERS. ORIENT TOWARD TRAFFIC FLOW.

BI-DIRECTIONAL YELLOW RAISED REFLECTIVE PAVEMENT MARKERS. INSTALL EVENLY SPACED (1' ON CENTER) AND ORIENT TOWARD TRAFFIC FLOW .

PAINT EACH END OF ISLAND WITH YELLOW RETRO-REFLECTIVE PAINT.

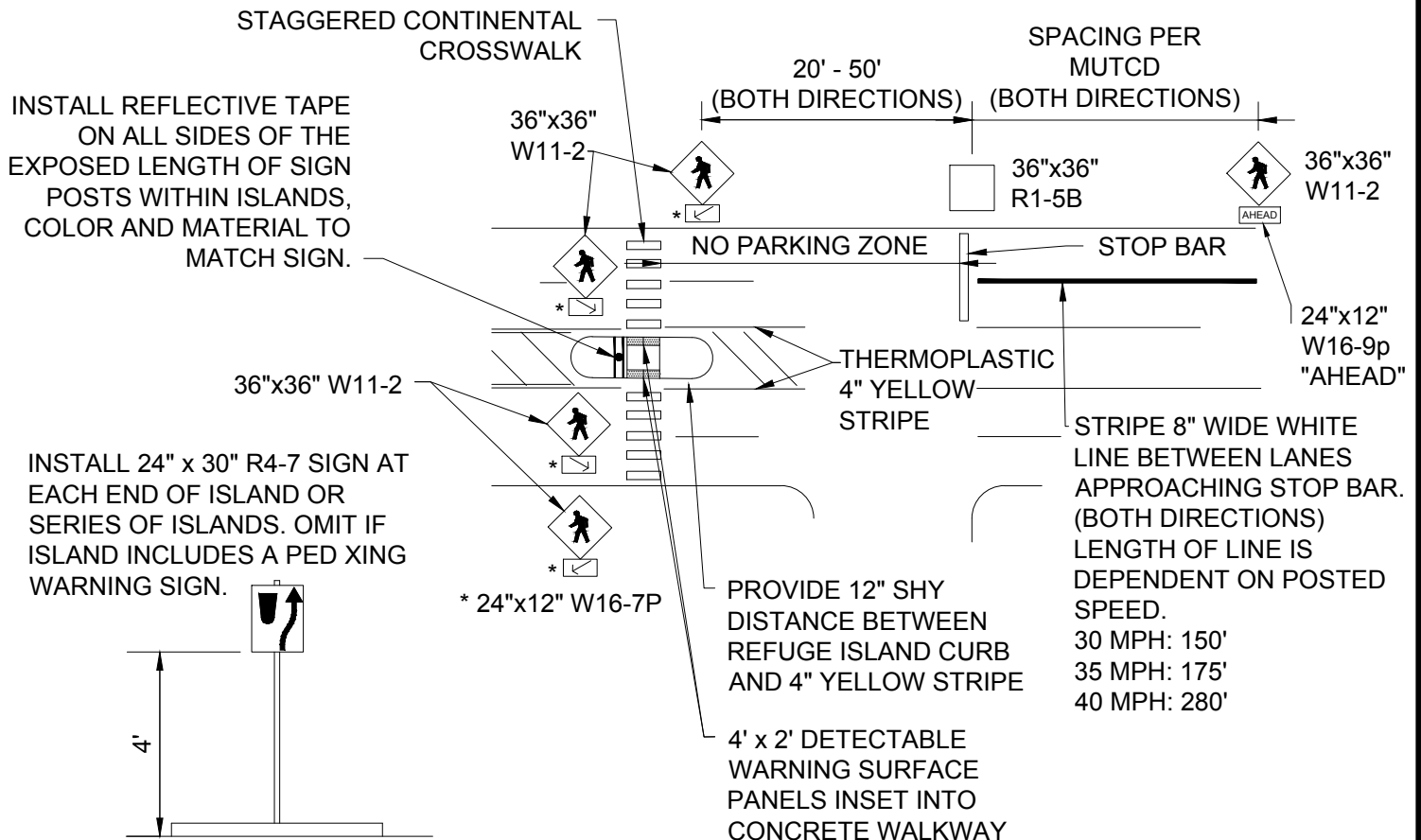

INSTALL 24" x 30" R4-7 SIGN AT EACH END OF ISLAND OR SERIES OF ISLANDS. OMIT IF ISLAND INCLUDES A PED XING WARNING SIGN.

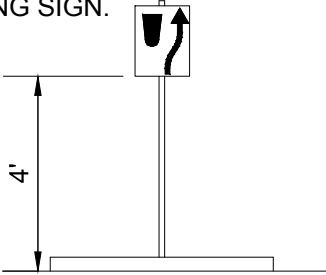

* 24"x12" W16-7P

PROVIDE 12" SHY DISTANCE BETWEEN REFUGE ISLAND CURB AND 4" YELLOW STRIPE

4' x 2' DETECTABLE WARNING SURFACE PANELS INSET INTO CONCRETE WALKWAY

STRIPE 8" WIDE WHITE LINE BETWEEN LANES APPROACHING STOP BAR. (BOTH DIRECTIONS) LENGTH OF LINE IS DEPENDENT ON POSTED SPEED.
 30 MPH: 150'
 35 MPH: 175'
 40 MPH: 280'

NOTES:

1. MIDBLOCK/SCHOOL CROSSWALK SHEETING SHALL BE 3M DIAMOND GRADE VIP FLUORESCENT YELLOW GREEN #3893 OR APPROVED EQUAL. ALL OTHER CROSSINGS SHALL USE YELLOW 3M HIGH INTENSITY PRISMATIC SHEETING #3931 OR APPROVED EQUAL.
2. ALL SIGNS SHALL BE COVERED WITH 3M PREMIUM PROTECTIVE OVERLAY FILM #1160 OR APPROVED EQUAL.
3. MINIMUM 50 FOOT ISLAND LENGTH UNLESS APPROVED BY THE CITY.

NTS



**MEDIAN ISLAND
SIGNING, STRIPING AND MARKING**

PWS VERSION: JULY 2026

DRAWN	CM
REV. DATE	JAN 2019
APPR.	
DETAIL NO.	636

FILENAME: y:\inter-departmental\development engineering projects\public works standards\2.0 pws revision copy\details\cad - all\600_transportation\637.dwg, Plotted 4/20/2026 11:18 AM, By: Anthony Dollowitch, ANSI FULL BLEED A (8.50 X 11.00 INCHES)

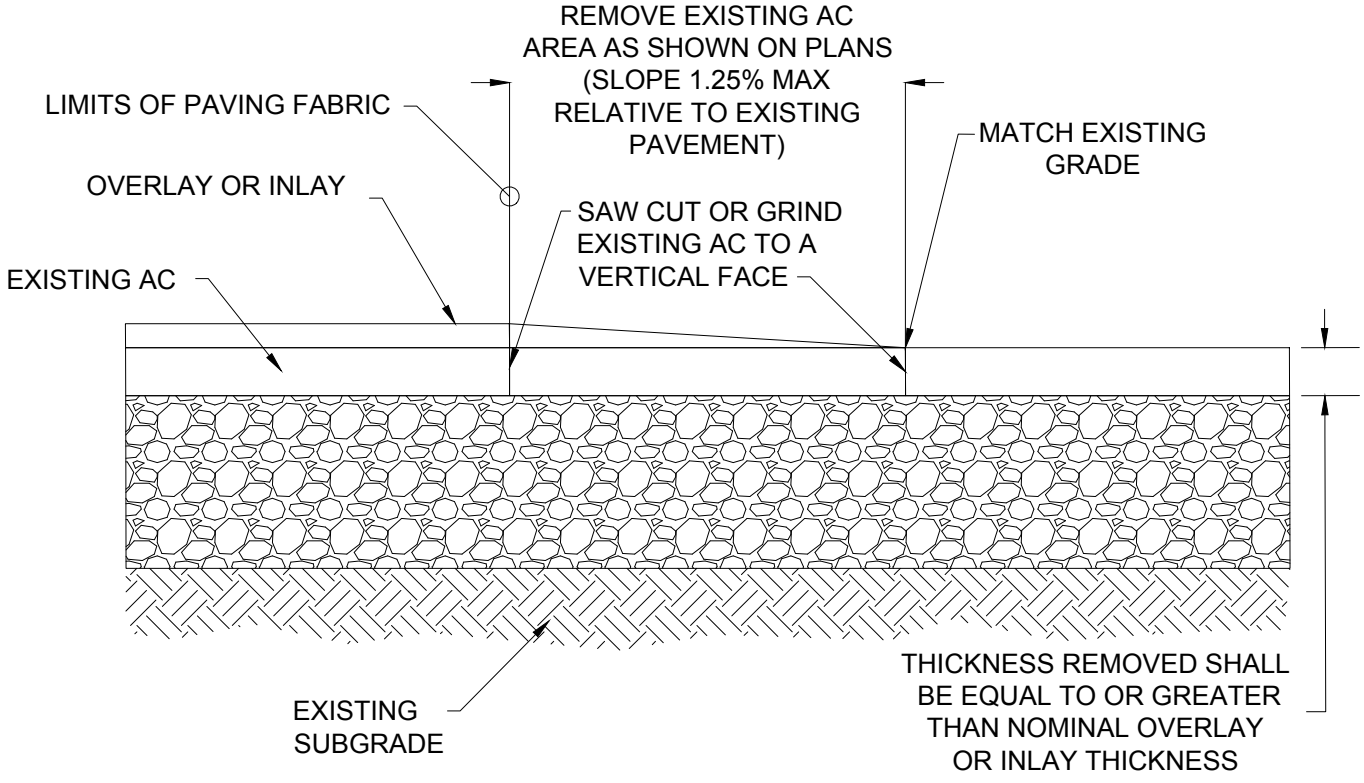

NOTES:

1. ALL SURFACES SHALL BE PROPERLY PREPARED AND TACKED PRIOR TO PLACEMENT OF ASPHALT.
2. ASPHALTIC CONCRETE SHALL BE COMPACTED TO 91% RICE DENSITY.

	<p>OVERLAY NOTCHING</p> <p>PWS VERSION: JULY 2026</p>	<p>DRAWN CM</p>
		<p>REV. DATE JAN 2019</p>
		<p>APPR.</p>
		<p>DETAIL NO. 637</p>

FILENAME: y:\inter-departmental\development engineering projects\public works standards\2.0 pws revision copy\details\cad - all\600_transportation\638.dwg, Plotted 4/20/2026 11:18 AM, By: Anthony Dollowitch, ANSI FULL BLEED A (8.50 X 11.00 INCHES)

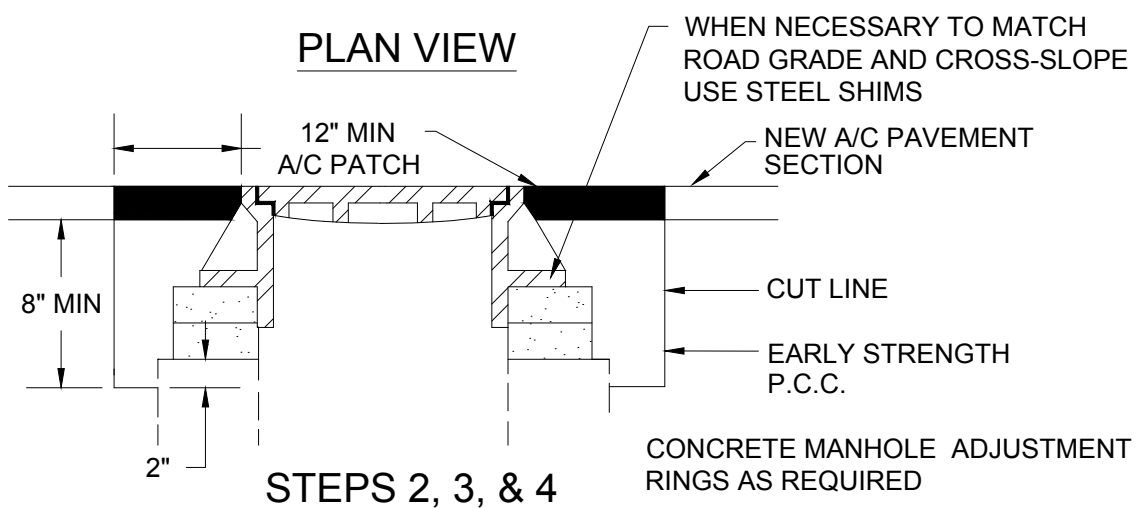
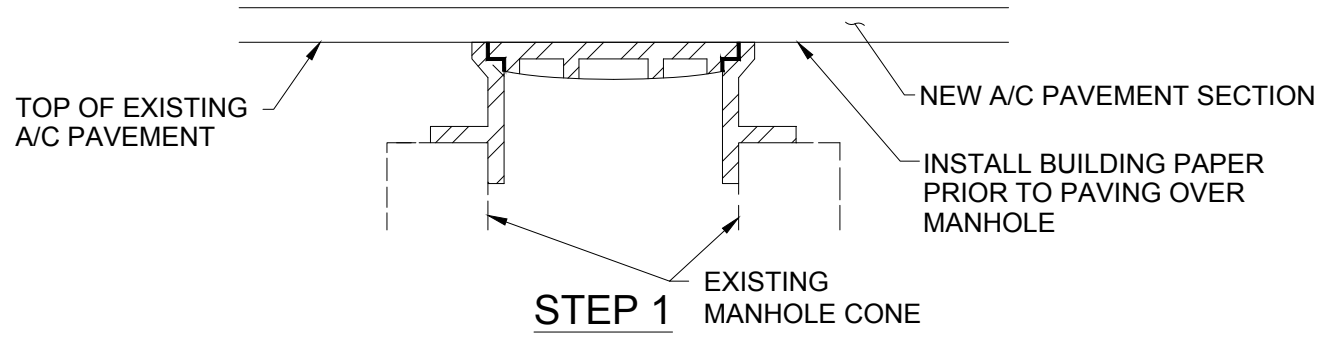
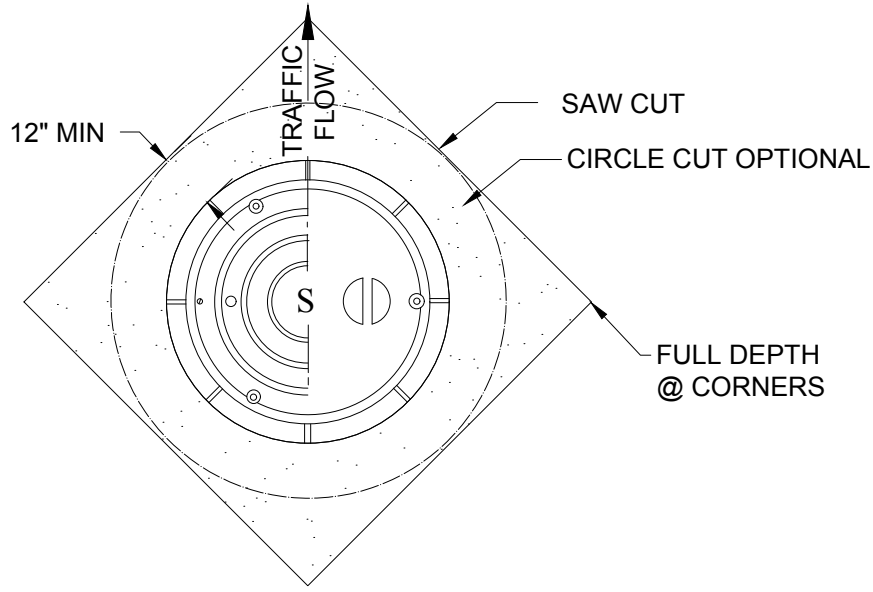

1. COVER EXISTING MANHOLE WITH BUILDING PAPER AND CONSTRUCT A/C PAVEMENT OVER TOP OF MANHOLE.
2. SAW CUT AND REMOVE PAVEMENT AROUND MANHOLE 12" MIN. FROM MANHOLE FRAME.
3. RAISE OR LOWER MANHOLE FRAME AND IF NECESSARY INSTALL CONCRETE RINGS TO FINISH PAVEMENT PROFILE AND CROSS SLOPE.
4. WHERE APPLICABLE, BACKFILL WITH 5000 PSI EARLY STRENGTH P.C.C. AND A/C TO DEPTHS AS DIRECTED.

CITY OF GRESHAM

MANHOLE FRAME ADJUSTMENT

PWS VERSION: JULY 2026

DRAWN	CM
REV. DATE	APRIL 2026
APPR.	
DETAIL NO.	638

FILENAME: y:\inter-departmental\development engineering projects\public works standards\2.0 pws revision copy\details\cad - all\600_transportation\639.dwg, Plotted 4/20/2026 11:18 AM, By: Anthony Dollowitch, ANSI FULL BLEED A (8.50 X 11.00 INCHES)

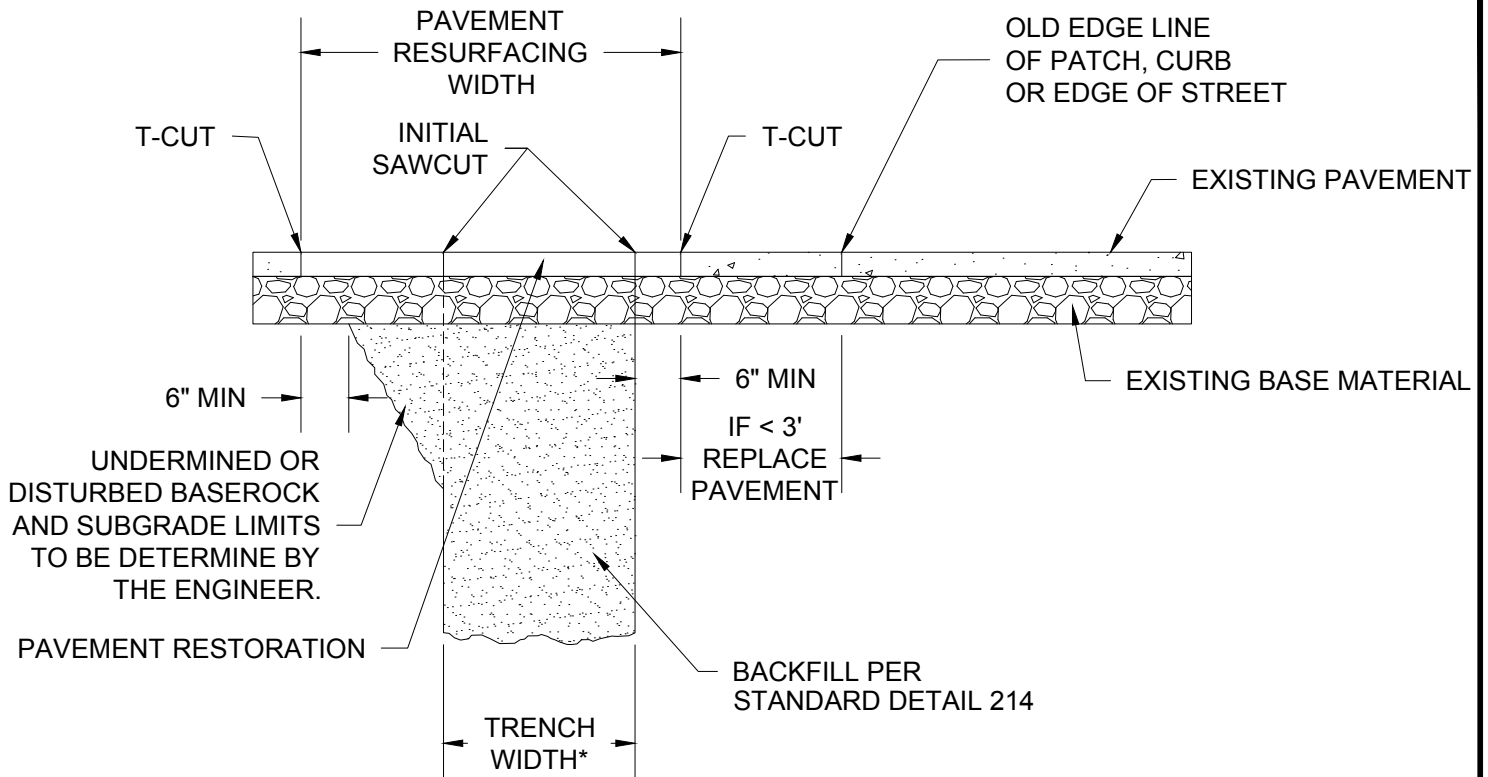

*IF TRENCH WIDTH IS LESS THAN THE WIDTH THAT CAN ACCOMMODATE MECHANICAL COMPACTION USE CONTROLLED LOW-STRENGTH MATERIAL FOR BACKFILL.

NOTES:

1. USE A MINIMUM 6" OVERLAP T-CUT DOWN TO THE BASE MATERIAL UNLESS OTHERWISE SPECIFIED. T-CUT TO BE MEASURED FROM THE INITIAL SAWCUT OR EDGE OF UNDERMINED BASEROCK, WHICHEVER RESULTS IN A WIDER REPLACEMENT SECTION.
2. IF NEW EDGE OF PAVEMENT IS LESS THAN 3' FROM ANOTHER PATCH, CURB OR EDGE OF STREET, REPLACE THE PAVEMENT IN BETWEEN.
3. IF MORE THAN ONE EXISTING PATCH EDGE IS WITHIN THE 3' ZONE, REMOVE PAVEMENT TO THE FAR EDGE OF THE PREEXISTING PATCH.
4. T-CUT SHALL NOT BE MADE UNTIL TRENCH IS FULLY BACKFILLED AND COMPACTED.
5. PAVEMENT SECTION (INCLUDING BASE ROCK) SHALL MATCH EXISTING FUNCTIONAL CLASSIFICATION SECTIONS AS SHOWN IN THE CURRENT VERSION OF THE CITY OF GRESHAM PUBLIC WORKS STANDARD DETAILS OR EXISTING PAVEMENT SECTION, WHICHEVER IS GREATER.
6. ALL TRENCH BACKFILL SHALL BE COMPACTED PER STANDARD DETAIL 214.
7. T-CUT SECTION SHALL BE MADE IN SOUND PAVEMENT ONLY AS DETERMINED BY THE ENGINEER. PAVEMENT CONDITION MAY REQUIRE THE 6" MIN TO BE EXCEEDED.
8. A/C SAW CUT SHALL BE SEALED WITH HOT POURED JOINT FILLER.

NTS

CITY OF GRESHAM

TRENCH PAVEMENT RESTORATION

PWS VERSION: JULY 2026

DRAWN	AAD
REV. DATE	JULY 2025
APPR.	
DETAIL NO.	639

FILENAME: y:\inter-departmental\development engineering projects\public works standards\2.0 pws revision copy\details\cad - all\600_transportation\640.dwg, Plotted 4/20/2026 11:18 AM, By: Anthony Dollowitch, ANSI FULL BLEED A (8.50 X 11.00 INCHES)

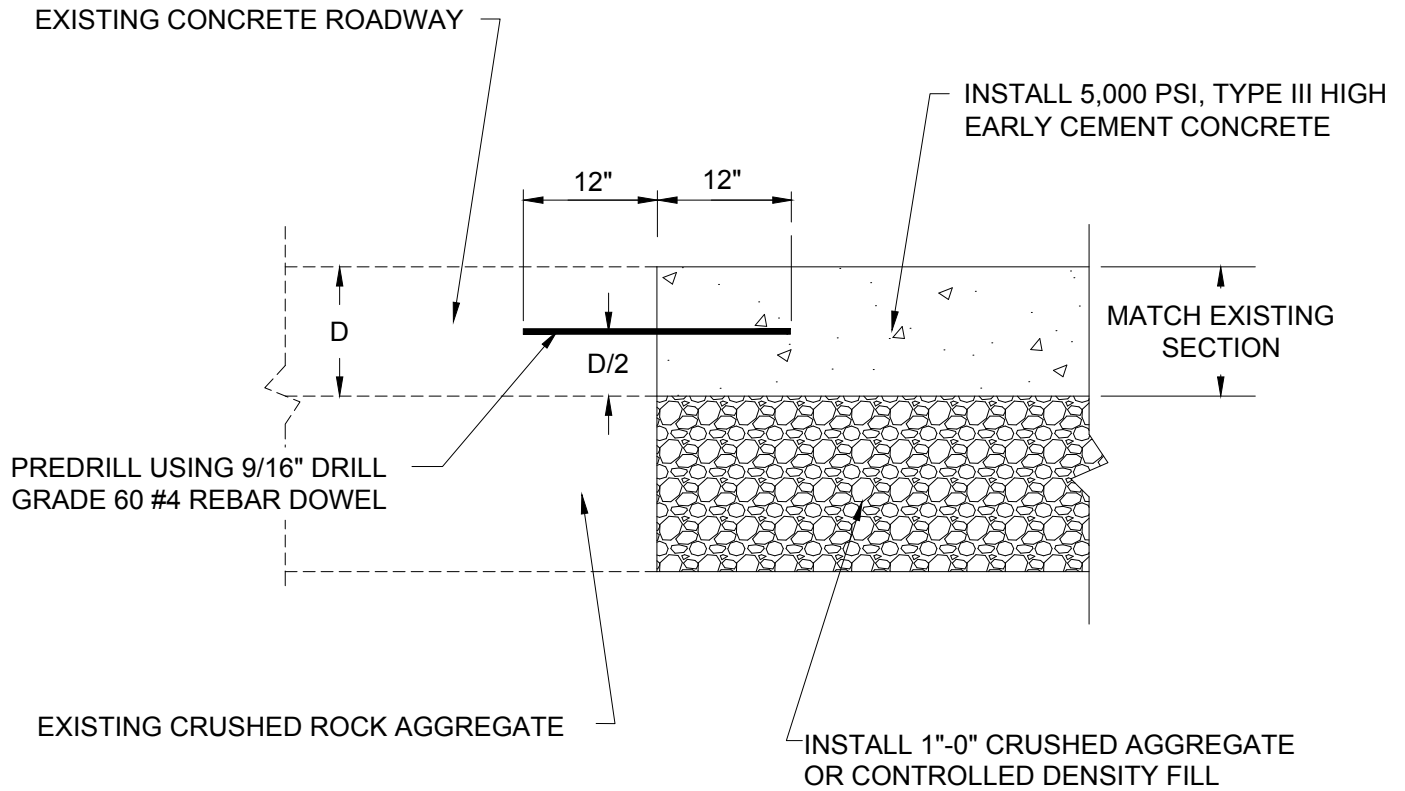

NOTES:

1. EXISTING SLAB SHALL BE DRILLED USING APPROPRIATE MASONRY DRILL BIT.
2. DOWELS SHALL BE PLACED AT 24" O.C.

NTS

CITY OF GRESHAM

PCC PAVEMENT RESTORATION

PWS VERSION: JULY 2026

DRAWN	AAD
REV. DATE	APRIL 2026
APPR.	
DETAIL NO.	640

FILENAME: y:\inter-departmental\development engineering projects\public works standards\2.0 pws revision copy\details\cad - all\600_transportation\641a.dwg, Plotted 4/20/2026 11:18 AM, By: Anthony Dollowitch, ANSI FULL BLEED A (8.50 X 11.00 INCHES)

INSTALL 6" X 18" WALL AROUND TREE GRATE ON ALL SIDES NOT INCLUDING THE CURB EDGE.

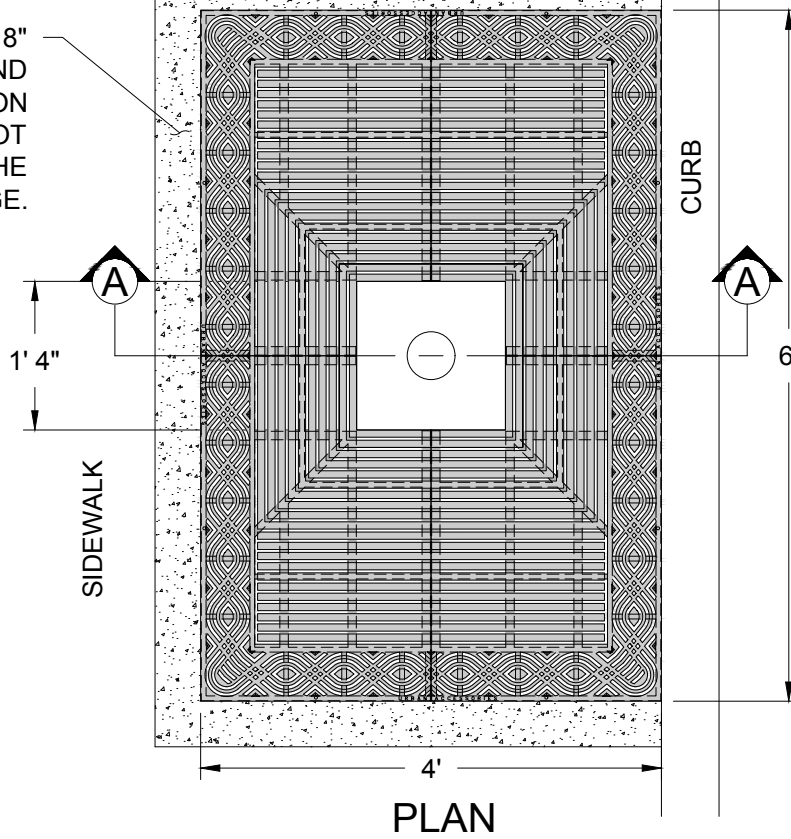

NOTE:

1. TREE GRATE SHALL BE URBAN ACCESSORIES RAW GRAY IRON CHINOOK TREE GRATE, OR APPROVED EQUAL.
2. TREE GRATES ARE REQUIRED IN REGIONAL & TOWN CENTERS & OTHER HIGH PEDESTRIAN AREAS AS DETERMINED BY THE ENGINEER.

PLAN

1 3/4" DIA. CALIPER TREE HEADED @ 6' TYP. EXCEPT 2" DIA CALIPER HEADED @ 8' SHALL BE USED WHEN TREE IS IN VISION TRIANGLE. TREES SHALL BE WELL BRANCHED, BALLED AND BURLAPED.

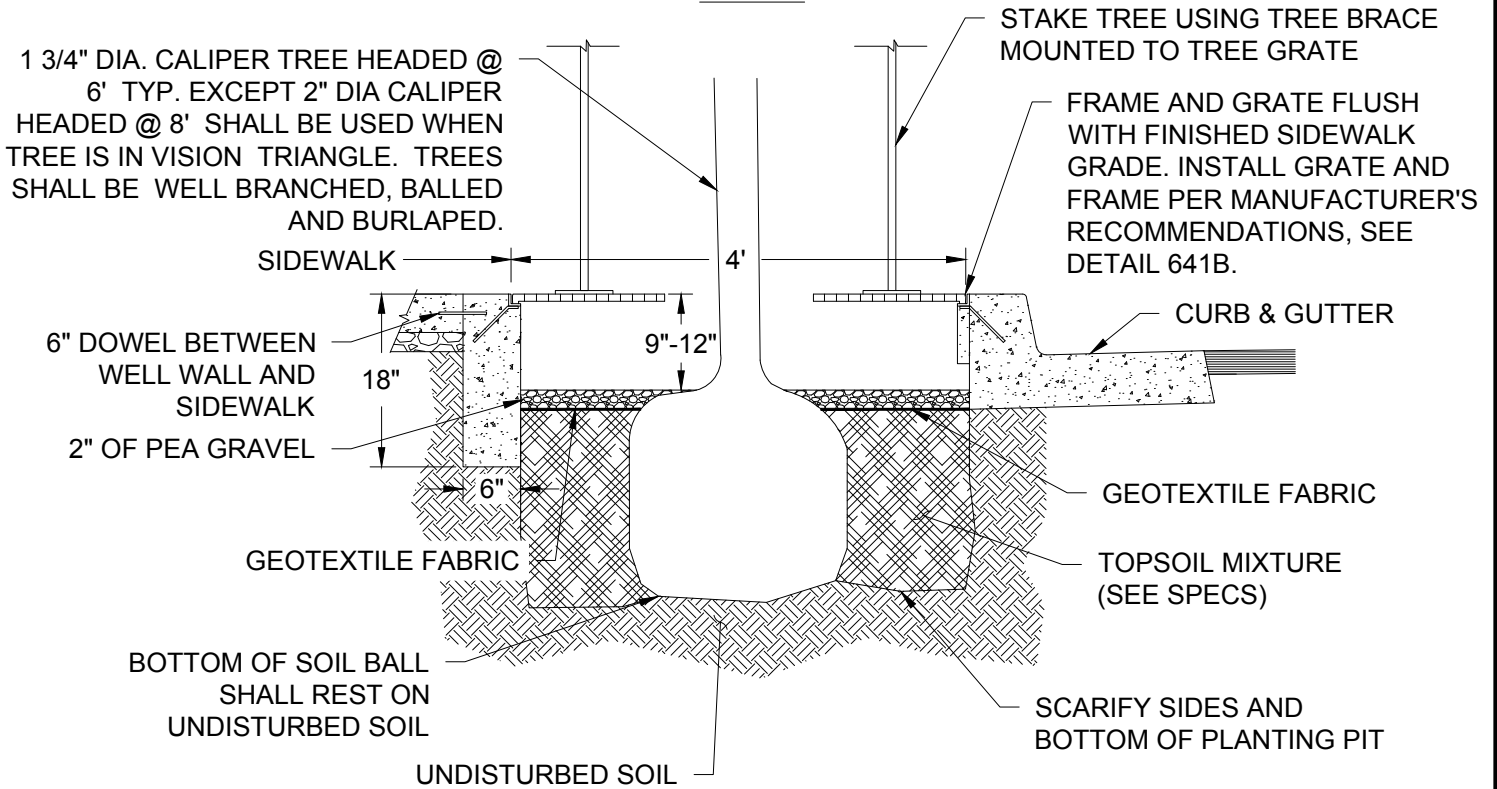

SECTION A-A

NTS

CITY OF GRESHAM

TOWN CENTER STREET TREE

PWS VERSION: JULY 2026

DRAWN	AAD
REV. DATE	JULY 2025
APPR.	
DETAIL NO.	641A

FILENAME: y:\inter-departmental\development\engineering\projects\public-works\standards\22\pws-rev\isometric\641B.dwg, Plotter: 4/20/2026 11:18:46 AM, By: Anthony, Dollowitch, ANS: FULL BE EED: A: (6:50X: 00:00:00)

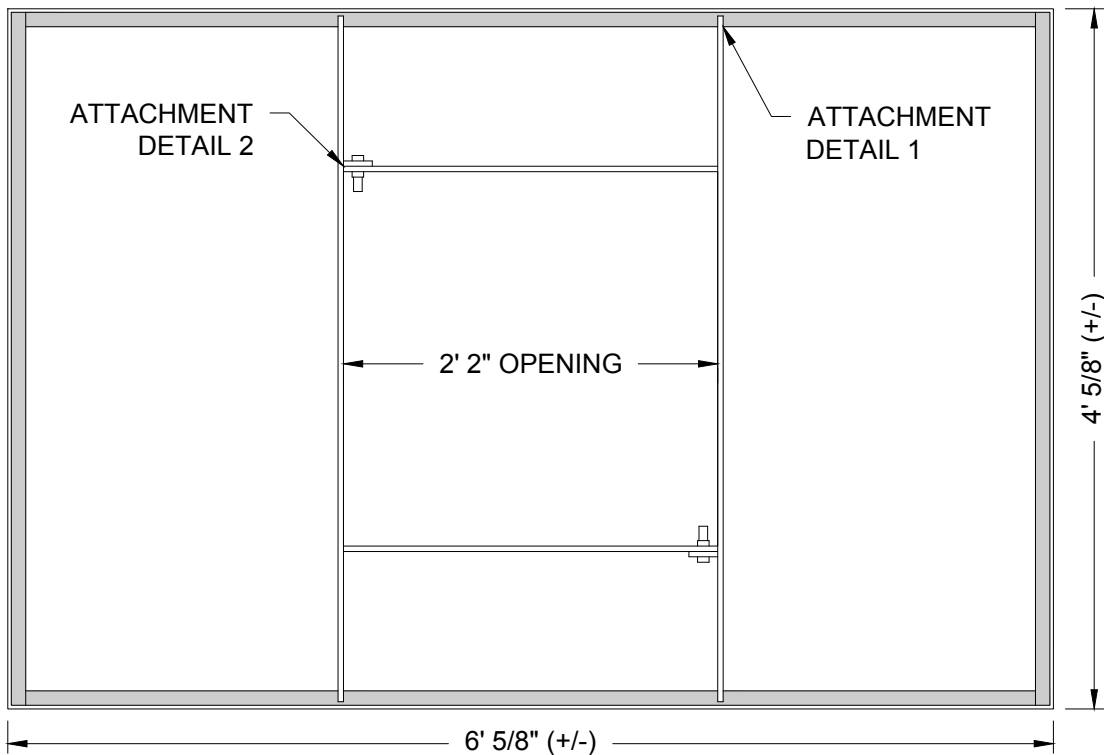

- NOTES:**
- TREE GRATE FRAME SHALL BE URBAN ACCESSORIES RAW STEEL (ASTM A36) TYPE "S" PEDESTRIAN DUTY, OR APPROVED EQUAL.

PLAN

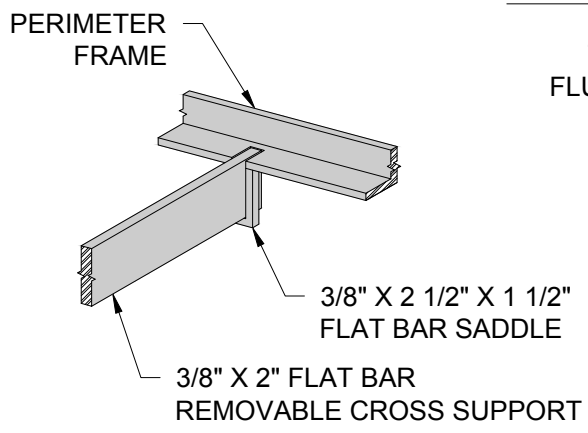

DETAIL 1

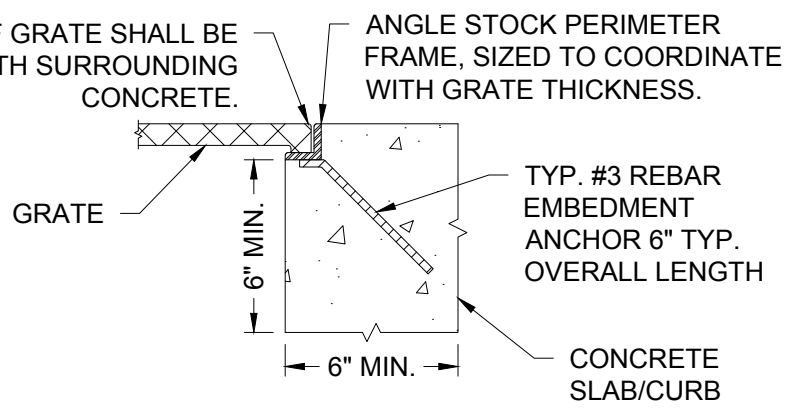

ELEVATION

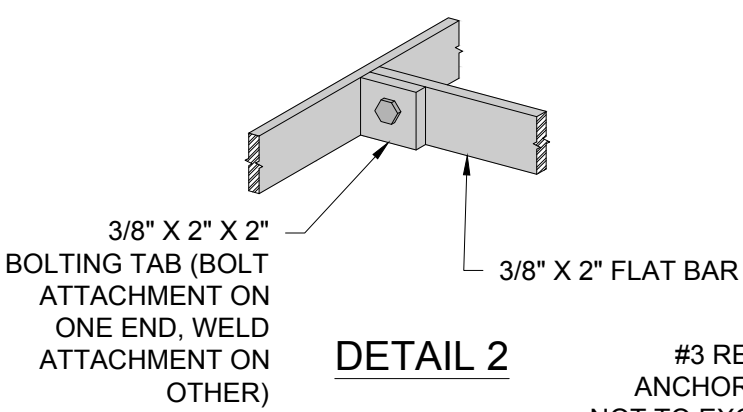

DETAIL 2

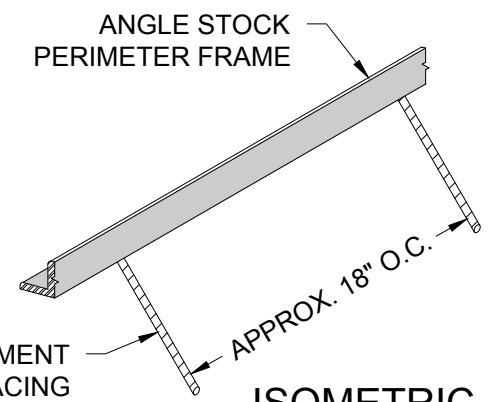

ISOMETRIC

#3 REBAR EMBEDMENT ANCHOR, EQUAL SPACING NOT TO EXCEED 18" O.C. TYP.



TOWN CENTER STREET TREE FRAME

PWS VERSION: JULY 2026

DRAWN	KRB
REV. DATE	JAN 2024
APPR.	
DETAIL NO.	641B

FILENAME: y:\inter-departmental\development engineering projects\public works standards\2.0 pws revision copy\details\cad - all\600_transportation\642a.dwg, Plotted 4/20/2026 11:18 AM, By: Anthony Dollowitch, ANSI FULL BLEED A (8.50 X 11.00 INCHES)

GUY ATTACHMENTS:
REMOVE HOSE COVERED
TREE ATTACHMENTS AFTER
2 YRS: HOSE LOOP IS
DOUBLE THE TRUNK
DIAMETER. GUYS NOT TAUT.

2" X 2" HARDWOOD STAKES
MAY BE LEFT TO PROVIDE
PHYSICAL PROTECTION TO
THE TREE TRUNK AND BARK

THE TOP OF THE TREE BALL
SHALL BE 3" HIGHER THAN
THE FINISHED SOIL GRADE

2-3" LAYER OF WOODY
MULCH, AGED WOOD CHIPS,
SHREDDED BARK, OR
SIMILAR MULCH. NEVER
MULCH AT TREE TRUNK

WATER THOROUGHLY
TO ELIMINATE AIR
POCKETS, SETTLING
AND TO SOAK BALL AND
SURROUNDING SOIL

SOIL MIXTURE SHALL
CONTAIN 4 PARTS NATIVE
SOIL TO 1 PART ORGANIC
MATERIAL.

REMOVE BURLAP, WIRE,
TWINE FROM THE TOP HALF
OF BALL ONLY.

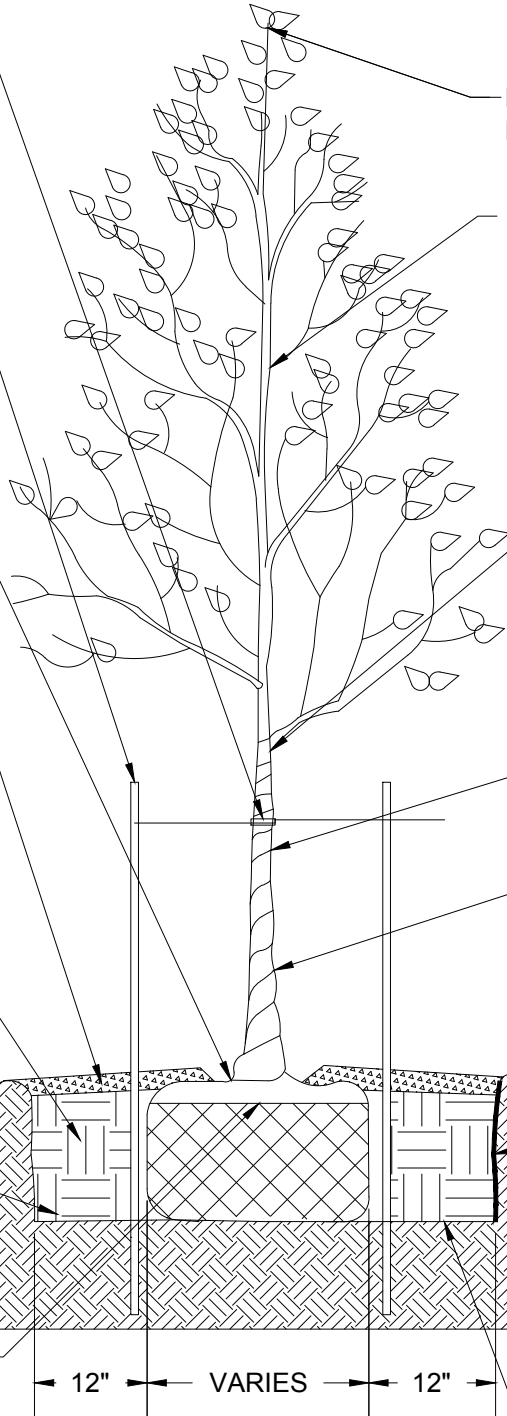

PRUNE LEADER ONLY TO REMOVE
DAMAGED OR BROKEN BRANCHES.

SINGLE STRAIGHT MAIN TRUNK TO
10' HEIGHT. BRANCHES BELOW
MAY EVENTUALLY REQUIRE
REMOVAL FOR HEIGHT CLEARANCE.

MINIMUM HEAD HEIGHT OF 6'.
REMOVE LOWER BRANCHES IN
SUCCESSIVE YEARS TO
PROVIDE A 14' CLEARANCE
OVER ARTERIALS AND
COLLECTORS, A 12' CLEARANCE
OVER ALL OTHER STREET
FUNCTIONAL CLASSIFICATIONS,
AND 8' CLEARANCE OVER
SIDEWALK.

IMMEDIATELY REMOVE
TRANSIT TRUNK GUARDS
AFTER PLANTING

CALIPER: USE 1 3/4" OR GREATER
DIAMETER MEASURE 6" ABOVE
GROUND. USE 2" IN CLEAR VISION
AREAS

SIDEWALK

INSTALL DEEPROOT ROOT
BARRIER SYSTEM, OR
APPROVED EQUAL,
ADJACENT TO SIDEWALKS
AND ADA FACILITIES. ROOT
BARRIER SHALL BE 18"
DEEP AND EXTEND 3 FEET
ON BOTH SIDES OF THE
TREE TRUNK.

12" VARIES 12"

DO NOT FERTILIZE UNTIL FALL
FOLLOWING SPRING PLANTING

NOTES:

1. NO SOIL SHALL BE ADDED TO THE TOP OF THE BALL NEAR THE TRUNK.
2. ROOT BALL SHALL REST DIRECTLY ON UNDISTURBED NATIVE SOIL AT THE BOTTOM OF THE HOLE.



STREET TREE PLANTING

PWS VERSION: JULY 2026

DRAWN	CM
REV. DATE	JAN 2024
APPR.	
DETAIL NO.	642A

FILENAME: y:\inter-departmental\development_engineering\projects\public works standards\2.0 pws revision copy\details\cad - all\600_transportation\643.dwg, Plotted 4/20/2026 11:19 AM, By: Anthony Dolloowitch, ANSI FULL BLEED A (8.50 X 11.00 INCHES)

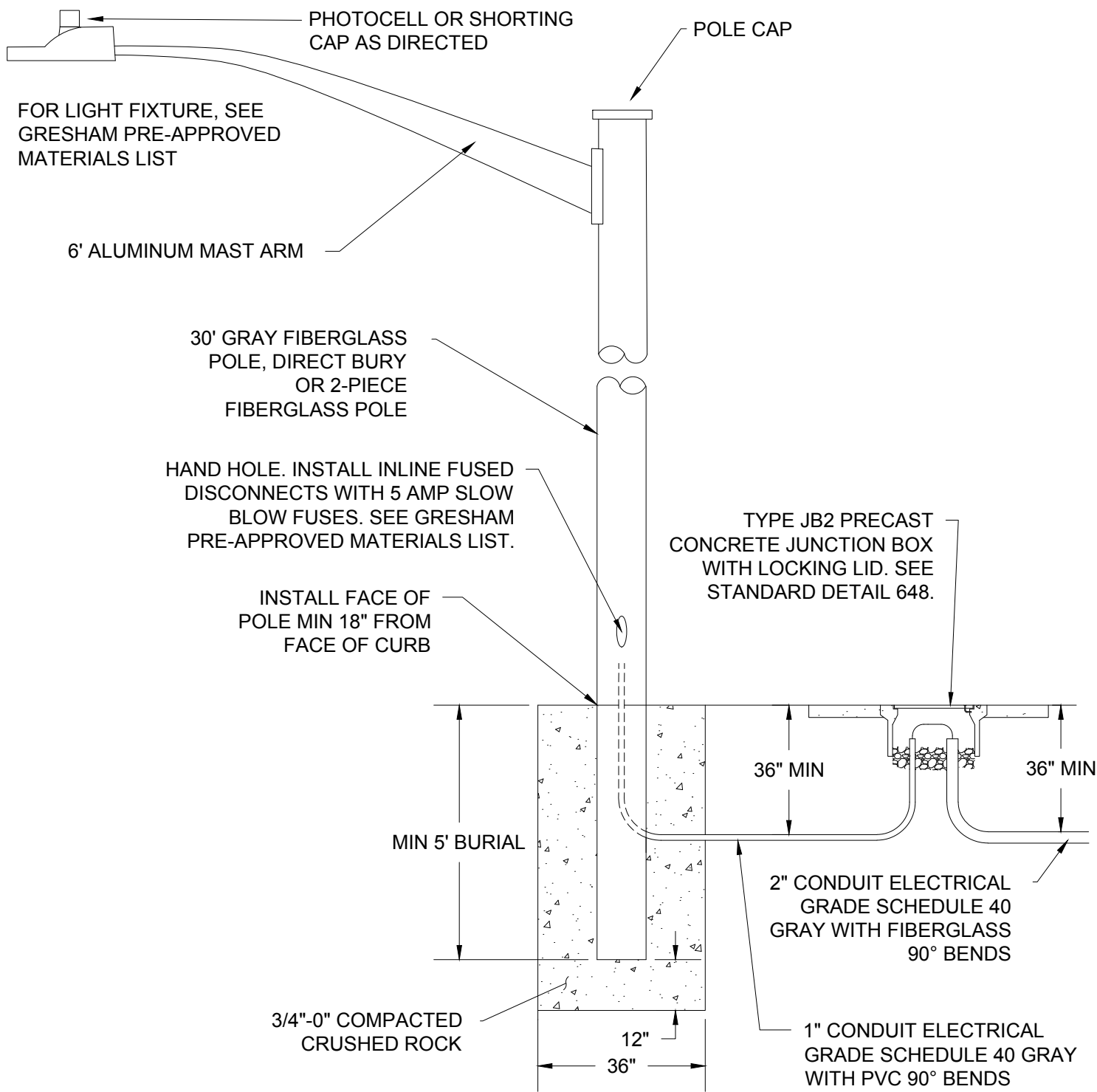

NOTES:

1. LUMINAIRE MOUNTING HEIGHT IS 25' ABOVE GROUND.
2. USE #10 AWG COPPER TC-ER 3-CONDUCTOR CABLE FROM FUSED DISCONNECT TO LIGHT FIXTURE. SEE PGE APPROVED PRODUCTS LIST. COLOR CODE: BLACK/RED/GREEN (240V), BLACK/WHITE/GREEN (120V).
3. INSTALL SHORTING CAP ON NEW STREETLIGHTS INSTALLED ON AN UNMETERED CITY ELECTRICAL SERVICE WITH CENTRAL PHOTO CONTROL.

NTS

	<h2>FIBERGLASS STREETLIGHT</h2>		DRAWN JG
	PWS VERSION: JULY 2026		REV. DATE MARCH 2026
	PWS VERSION: JULY 2026		APPR.
	PWS VERSION: JULY 2026		DETAIL NO. 643

FILENAME: y:\inter-departmental\development_engineering_projects\public_works_standards\2.0_pws_revision_copy\details\cad - all\600_transportation\644.dwg, Plotted 4/20/2026 11:19 AM, By: Anthony Dollowitch, ANSI FULL BLEED A (8.50 X 11.00 INCHES)

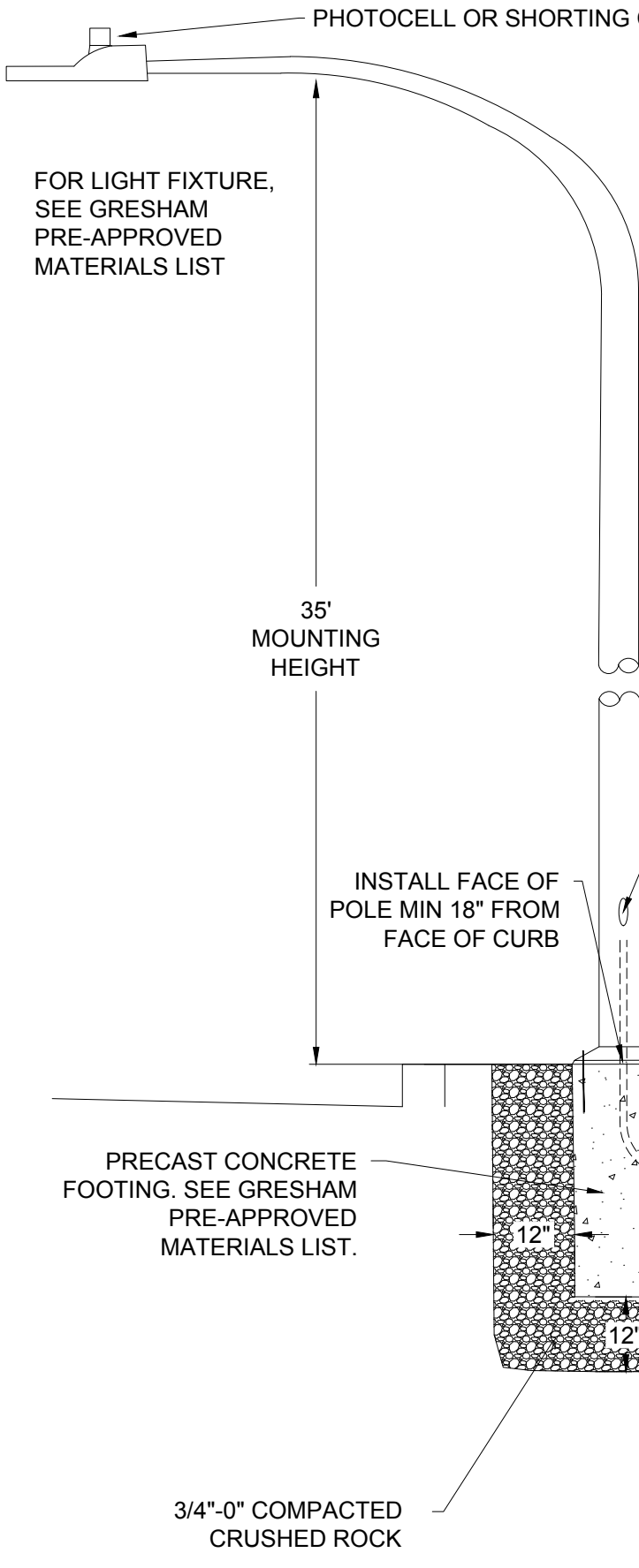

NOTES:

1. LUMINAIRE MOUNTING HEIGHT IS 35' ABOVE GROUND.
2. ARM LENGTH 6' OR AS DIRECTED.
3. USE #10 AWG COPPER TC-ER 3-CONDUCTOR CABLE FROM FUSED DISCONNECT TO LIGHT FIXTURE. SEE PGE APPROVED PRODUCTS LIST. COLOR CODE: BLACK/RED/GREEN (240V), BLACK/WHITE/GREEN (120V).
4. INSTALL SHORTING CAP ON NEW STREETLIGHTS INSTALLED ON AN UNMETERED ELECTRICAL SERVICE WITH CENTRAL PHOTO CONTROL.

HAND HOLE. BOND EQUIPMENT GROUND TO POLE. INSTALL INLINE FUSED DISCONNECTS WITH 5 AMP SLOW BLOW FUSES. SEE GRESHAM PRE-APPROVED MATERIALS LIST.

NTS

CITY OF GRESHAM

ALUMINUM DAVIT STREETLIGHT

PWS VERSION: JULY 2026

DRAWN	JG
REV. DATE	MARCH 2026
APPR.	
DETAIL NO.	644

FILENAME: y:\inter-departmental\development engineering projects\public works standards\2.0 pws revision copy\details\cad - all\600_transportation\645.dwg, Plotted: 4/20/2026 11:19 AM, By: Anthony Dollowitch, ANSI FULL BLEED A (8.50 X 11.00 INCHES)

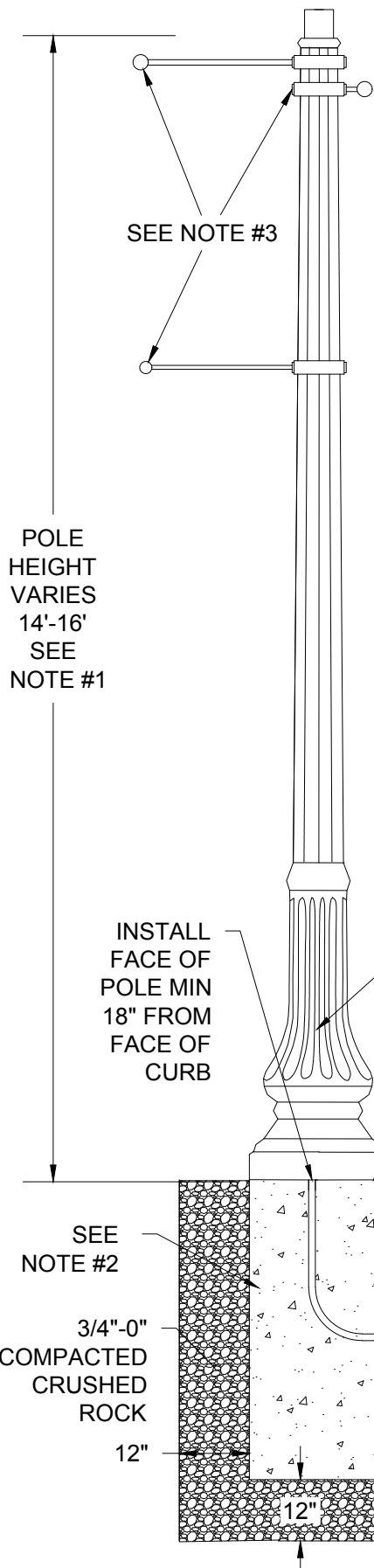

ACORN STYLE FIXTURE

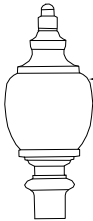

FOR LIGHT FIXTURE AND PHOTOCELL, SEE GRESHAM PRE-APPROVED MATERIALS LIST. INSTALL SHORTING CAP IN PLACE OF PHOTOCELL AS DIRECTED.

NOTES:

1. ALUMINUM FLUTED TAPERED POLE, COLOR BLACK. USE 14' POLE ON LOCAL STREETS AND 16' POLE ON COLLECTOR OR ARTERIAL STREETS. SEE GRESHAM PRE-APPROVED MATERIALS LIST.
2. USE PRECAST CONCRETE FOOTING WITH AN 11" BOLT CIRCLE. SEE GRESHAM PRE-APPROVED MATERIALS LIST.
3. BANNER ARM AND PLANT HANGER REQUIRED IN DOWNTOWN PLAN DISTRICT.
4. USE #10 AWG COPPER TC-ER 3-CONDUCTOR CABLE FROM FUSED DISCONNECT TO LIGHT FIXTURE. SEE PGE APPROVED PRODUCTS LIST. COLOR CODE: BLACK/RED/GREEN (240V), BLACK/WHITE/GREEN (120V).
5. INSTALL SHORTING CAP ON NEW STREETLIGHTS INSTALLED ON AN UNMETERED CITY ELECTRICAL SERVICE WITH CENTRAL PHOTO CONTROL.

SEE NOTE #3

POLE HEIGHT VARIES 14'-16' SEE NOTE #1

INSTALL FACE OF POLE MIN 18" FROM FACE OF CURB

POLE ACCESS DOOR. BOND EQUIPMENT GROUND TO POLE. INSTALL INLINE FUSED DISCONNECTS WITH 5 AMP SLOW BLOW FUSES. SEE GRESHAM PRE-APPROVED MATERIALS LIST.

GROUT TO FILL GAP BETWEEN POLE BASEPLATE AND FOUNDATION

TYPE JB2 PRECAST CONCRETE JUNCTION BOX WITH LOCKING LID. SEE STANDARD DETAIL 648.

36" MIN

36" MIN

2" CONDUIT ELECTRICAL GRADE SCHEDULE 40 GRAY WITH FIBERGLASS 90° BENDS

1" CONDUIT ELECTRICAL GRADE SCHEDULE 40 GRAY WITH PVC 90° BENDS

8' GALVANIZED STEEL GROUND ROD. BOND TO POLE WITH #6 AWG COPPER GROUND WIRE AND ACORN CLAMP.

SEE NOTE #2

3/4"-0" COMPACTED CRUSHED ROCK

12"

12"

NTS

	<h2 style="margin: 0;">DECORATIVE ACORN STREETLIGHT</h2>		DRAWN JG
	<p style="font-size: small;">PWS VERSION: JULY 2026</p>		REV. DATE MARCH 2026
			APPR.
			DETAIL NO. 645

FILENAME: y:\inter-departmental\development engineering projects\public works standards\2.0 pws revision copy\details\cad - all\600_transportation\647.dwg, Plotted: 4/20/2026 11:19 AM, By: Anthony Dollowitch, ANSI FULL BLEED A (8.50 X 11.00 INCHES)

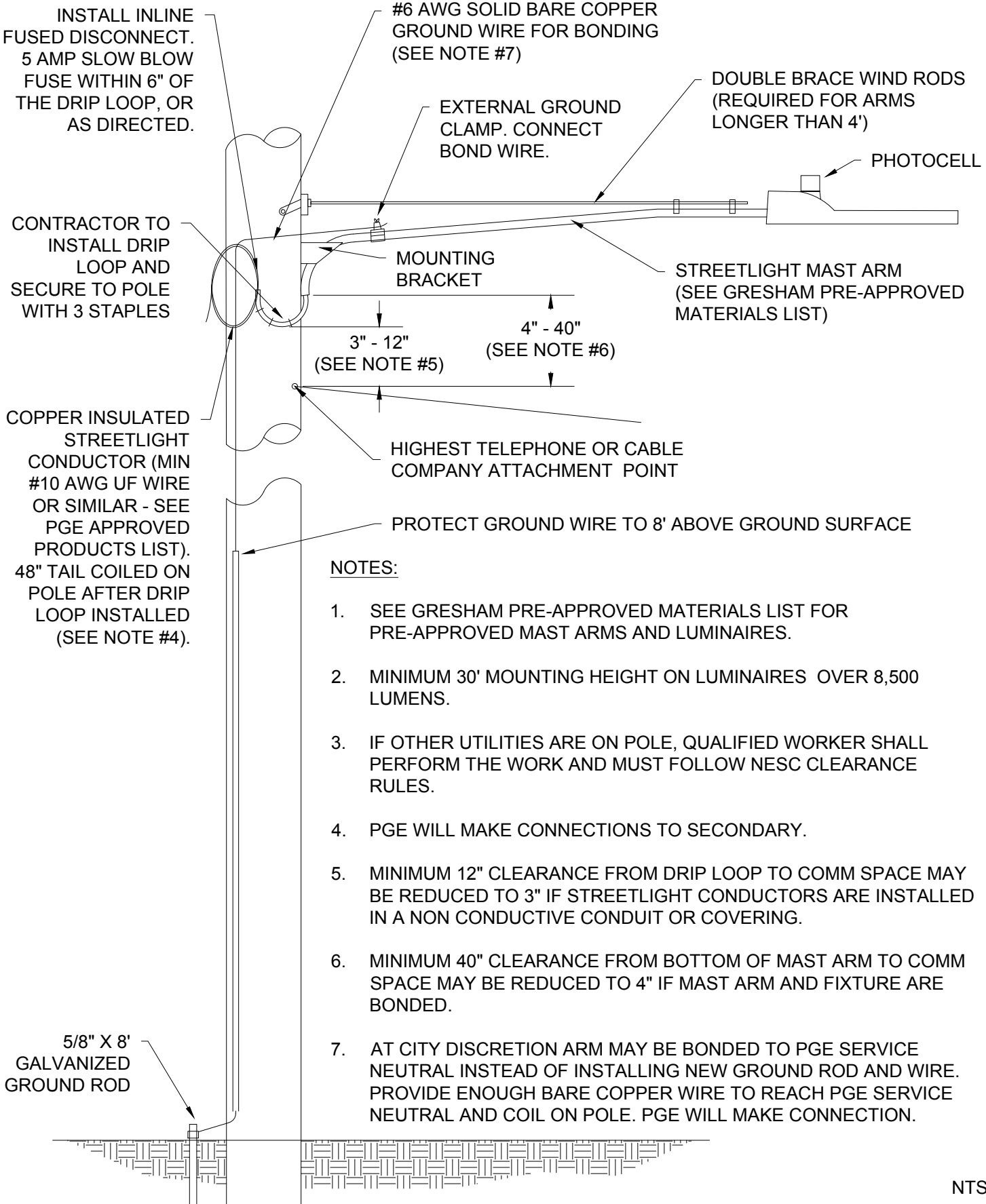

NOTES:

1. SEE GRESHAM PRE-APPROVED MATERIALS LIST FOR PRE-APPROVED MAST ARMS AND LUMINAIRES.
2. MINIMUM 30' MOUNTING HEIGHT ON LUMINAIRES OVER 8,500 LUMENS.
3. IF OTHER UTILITIES ARE ON POLE, QUALIFIED WORKER SHALL PERFORM THE WORK AND MUST FOLLOW NESC CLEARANCE RULES.
4. PGE WILL MAKE CONNECTIONS TO SECONDARY.
5. MINIMUM 12" CLEARANCE FROM DRIP LOOP TO COMM SPACE MAY BE REDUCED TO 3" IF STREETLIGHT CONDUCTORS ARE INSTALLED IN A NON CONDUCTIVE CONDUIT OR COVERING.
6. MINIMUM 40" CLEARANCE FROM BOTTOM OF MAST ARM TO COMM SPACE MAY BE REDUCED TO 4" IF MAST ARM AND FIXTURE ARE BONDED.
7. AT CITY DISCRETION ARM MAY BE BONDED TO PGE SERVICE NEUTRAL INSTEAD OF INSTALLING NEW GROUND ROD AND WIRE. PROVIDE ENOUGH BARE COPPER WIRE TO REACH PGE SERVICE NEUTRAL AND COIL ON POLE. PGE WILL MAKE CONNECTION.

NTS



LUMINAIRE MOUNTED ON WOOD POLE

PWS VERSION: JULY 2026

DRAWN	JG
REV. DATE	JAN 2019
APPR.	
DETAIL NO.	647

FILENAME: y:\inter-departmental\development engineering projects\public works standards\20 pws revision copy\details\cad - all\600_transportation\648.dwg, Plotted: 4/20/2026 11:19 AM, By: Anthony Dollowitch, ANSI FULL BLEED A (8.50 X 11.00 INCHES)

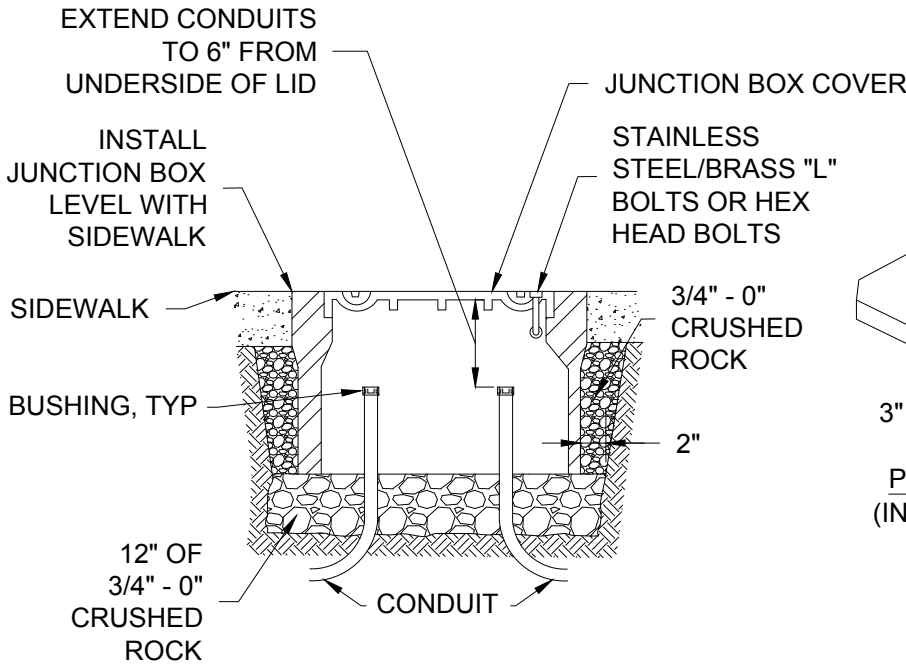

INSTALLATION IN SIDEWALK OR AT BACK OF CURB

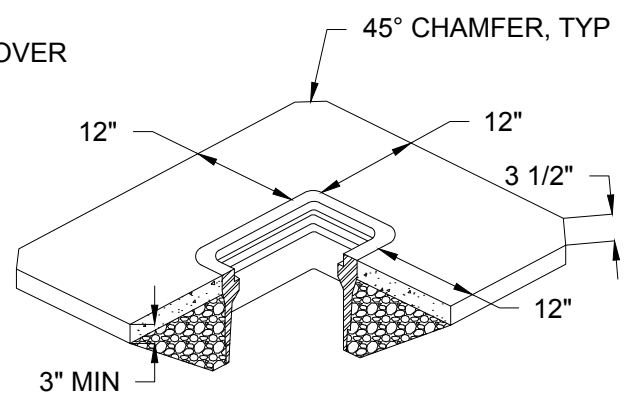

PORTLAND CEMENT CONCRETE PAD
(INSTALLATION OUTSIDE OF SIDEWALK
ONLY WITH MANAGER APPROVAL)

TYPE	L	W	D
JB1	17"	10"	12"
JB2	22"	12"	12"
JB3	30"	17"	12"

JUNCTION BOX DIMENSION TABLE

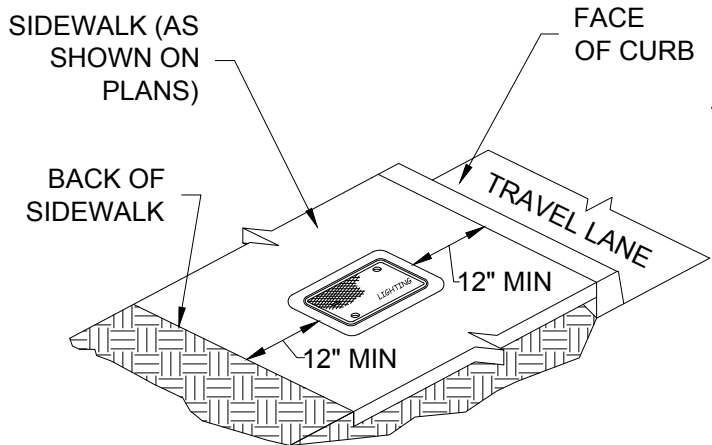

JUNCTION BOX PLACEMENT WITHIN SIDEWALKS

JUNCTION BOXES TO BE LOCATED ONLY IN FLAT AREAS OF SIDEWALKS. CONCRETE JUNCTION BOXES ARE NOT TO BE INSTALLED IN SLOPES OF RAMPS OR IN DRIVEWAYS.

NEW JUNCTION BOXES INSTALLED IN EXISTING SIDEWALKS SHALL INCLUDE A FULL PANEL REMOVAL AND REINSTALLATION.

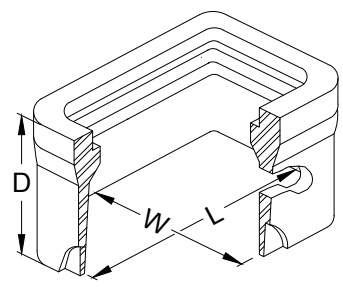
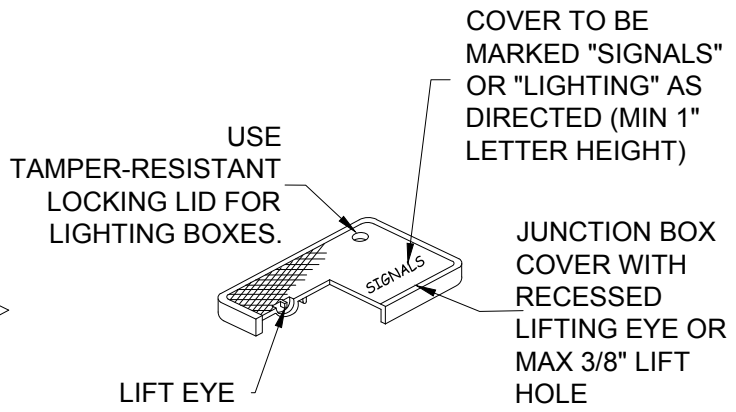

JUNCTION BOX

NOT TO BE USED IN TRAVEL LANES, SHOULDERS OR AREAS EXPOSED TO TRAFFIC. SEE GRESHAM PRE-APPROVED MATERIALS LIST.

NTS



ELECTRICAL JUNCTION BOXES

PWS VERSION: JULY 2026

DRAWN	CM
REV. DATE	JAN 2024
APPR.	
DETAIL NO.	648

FILENAME: y:\inter-departmental\development\engineering\projects\public\works\standards\2.0\pws_revision\copy\details\cad - all\600_transportation\649.dwg, Plotted 4/20/2026 11:19 AM, By: Anthony Dollowitch, ANSI FULL BLEED A (8.50 X 11.00 INCHES)

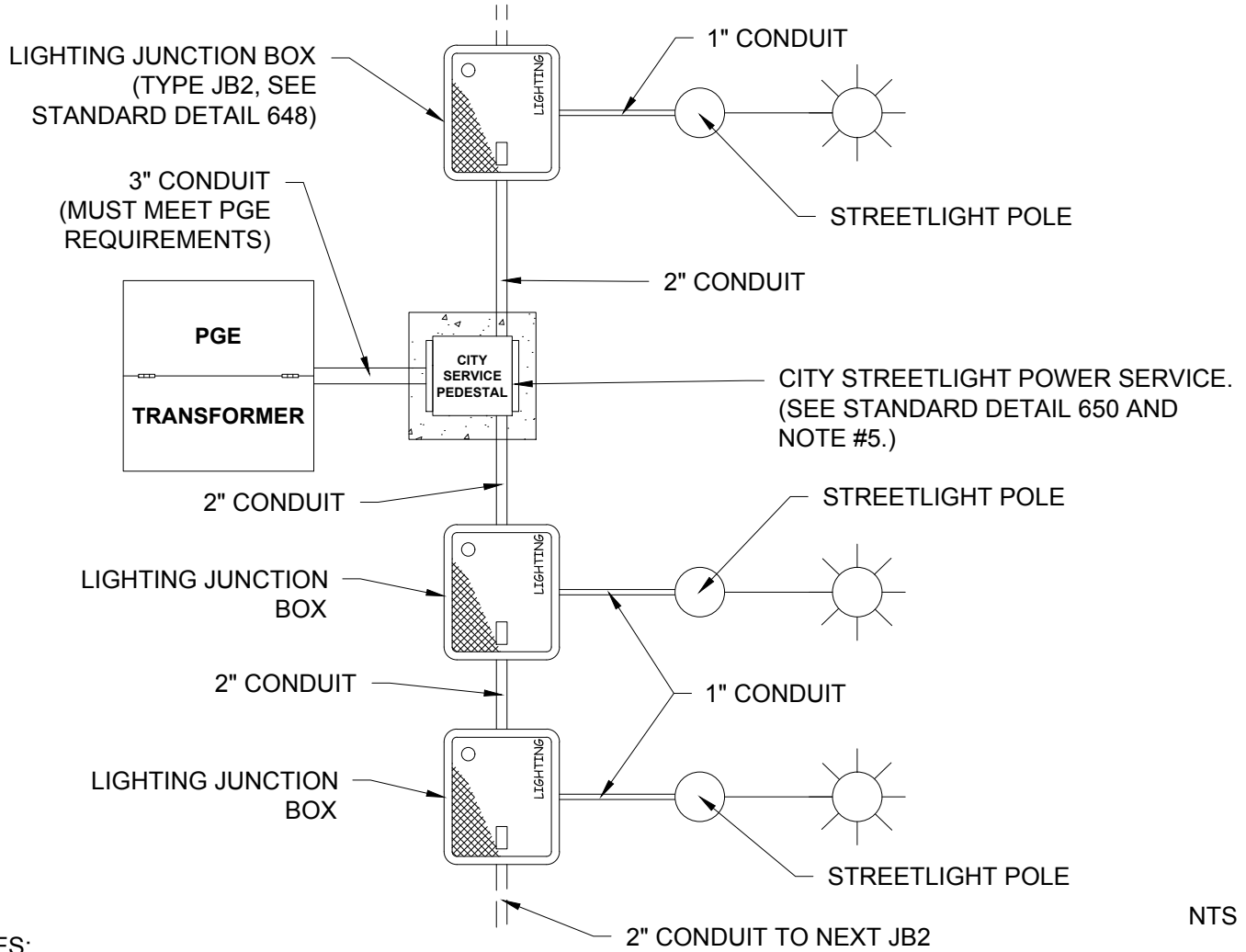

NOTES:

1. MINIMUM WIRE SIZE #8 AWG. WIRES SHALL BE UPSIZED AS REQUIRED TO KEEP VOLTAGE DROP TO LESS THAN 3%. XHHW-2. COLOR CODE: BLACK/RED/GREEN (240V), BLACK/WHITE/GREEN (120V). LINE VOLTAGE WIRES MUST BE CONTINUOUS BETWEEN POLE HAND HOLES.
2. ALL CONDUITS BETWEEN JUNCTION BOXES MUST HAVE A #14 AWG LOCATE WIRE, COLOR ORANGE WITH EITHER BLUE STRIPE OR BLUE MARKINGS. TIE LOCATE WIRES TOGETHER IN EACH JUNCTION BOX AND LOOP A SPARE 18" IN EACH BOX. EMPTY CONDUITS MUST HAVE A POLY PULL LINE, 500 POUND RATED, WITH 6' OF LINE EXTENDING FROM EACH END.
3. INSTALL ELECTRICAL GRADE SCHEDULE 40 GRAY PVC CONDUIT. FIBERGLASS BENDS ARE REQUIRED FOR ALL CONDUIT RUNS LONGER THAN 20'. ALL PVC JOINTS SHALL BE GLUED. ALL FACTORY OR FIELD-CUT CONDUITS SHALL BE CHAMFERED TO PREVENT DAMAGE TO CABLES. CONDUITS SHALL BE TESTED AFTER INSTALLATION FOR OBSTRUCTIONS AND OUT-OF-ROUND INSTALLATION.
4. CITY OF GRESHAM ELECTRICAL BUILDING PERMIT REQUIRED.
5. A NEW LIGHTING SYSTEM WITH FEWER THAN 4 NEW STREET LIGHTS MAY OMIT THE SERVICE PEDESTAL AND INSTALL FUSED DISCONNECTS IN A JB2. REQUIRES INSTALLATION OF A SEPARATE PGE TYPE 1730 JUNCTION BOX BETWEEN THE TRANSFORMER AND JB2 WITH FUSED DISCONNECTS. 1730 BOX MUST BE MIN 15', MAX 50' FROM TRANSFORMER.
6. TO SUPPORT FUTURE DEVELOPMENT, CITY MAY REQUIRE CONDUIT EXTENDED TO PROPERTY LINE.

NTS

	<h2>STREETLIGHT POWER SERVICE AND CONDUIT SYSTEM</h2>	DRAWN AAD
		REV. DATE JULY 2025
		APPR.
	PWS VERSION: JULY 2026	

FILENAME: y:\inter-departmental\development engineering projects\public works standards\2.0 pws revision copy\details\cad - all\600_transportation\650.dwg, Plotted 4/20/2026 11:19 AM, By: Anthony Dollowitch, ANSI FULL BLEED A (8.50 X 11.00 INCHES)

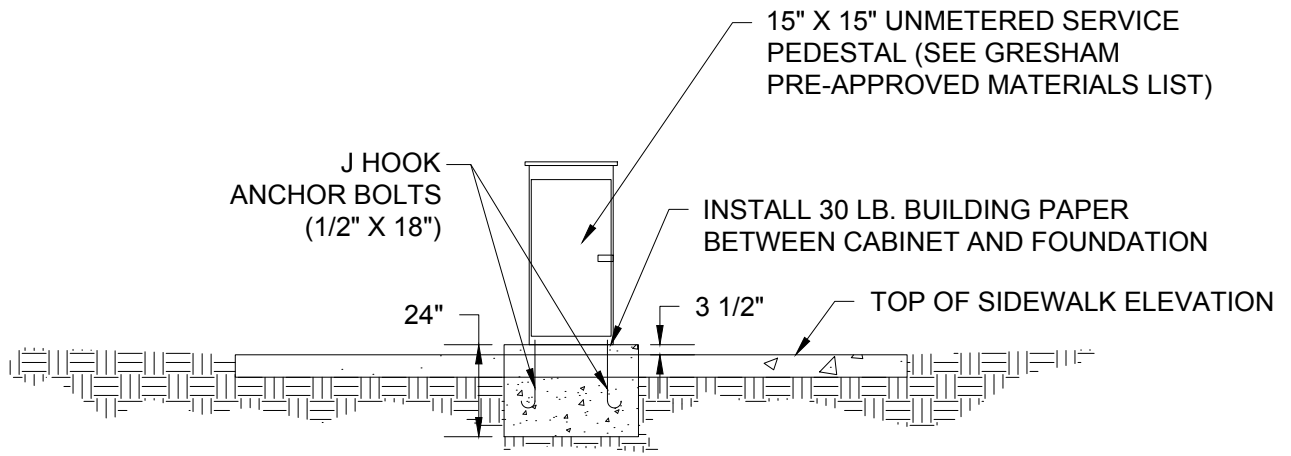

PROFILE VIEW

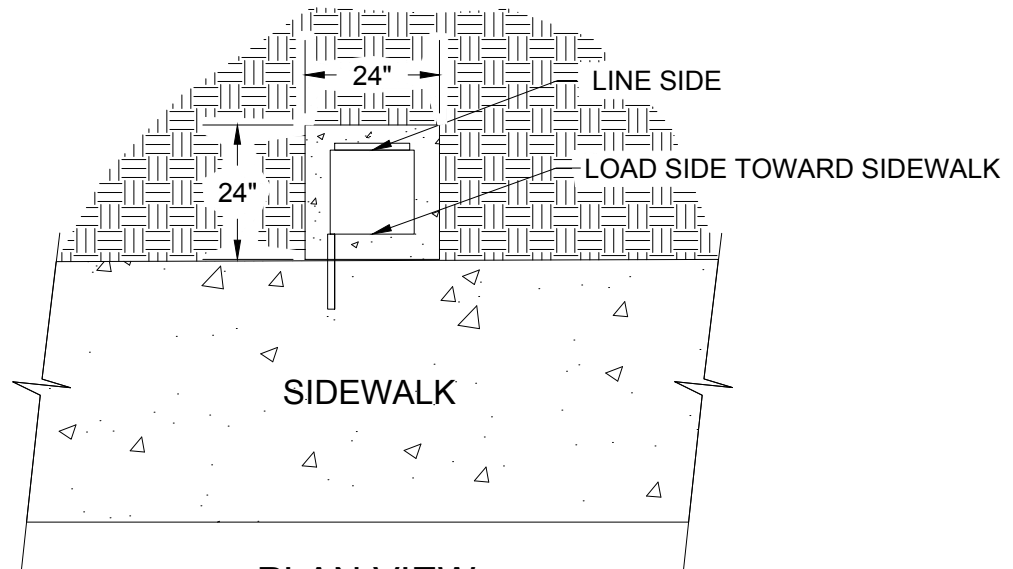

PLAN VIEW

NOTES:

1. A SERVICE INSTALLATION REQUIRES TWO GROUND RODS SPACED A MINIMUM OF 6 FEET APART. ONE GROUND ROD MAY BE INSTALLED THROUGH THE CABINET FOUNDATION.
2. EXTEND CONDUIT ENDS MINIMUM 2" AND MAXIMUM 3" ABOVE TOP OF CABINET FOUNDATION.
3. FOUNDATIONS AND GROUND ROD JUNCTION BOXES MUST BE INSTALLED WITHIN CITY RIGHT-OF-WAY OR WITHIN A GENERAL UTILITY EASEMENT.

NTS

**CITY OF
GRESHAM**

**STREETLIGHT ELECTRICAL
SERVICE PEDESTAL**

PWS VERSION: JULY 2026

DRAWN JG

REV. DATE JAN 2024

APPR.

DETAIL NO. 650

FILENAME: y:\inter-departmental\development_engineering_projects\public_works_standards\20_pws_revision_copy\details\cad - all\600_transportation\651.dwg, Plotted 4/20/2026 11:19 AM, By: Anthony Dollowitch, ANSI FULL BLEED A (8.50 X 11.00 INCHES)

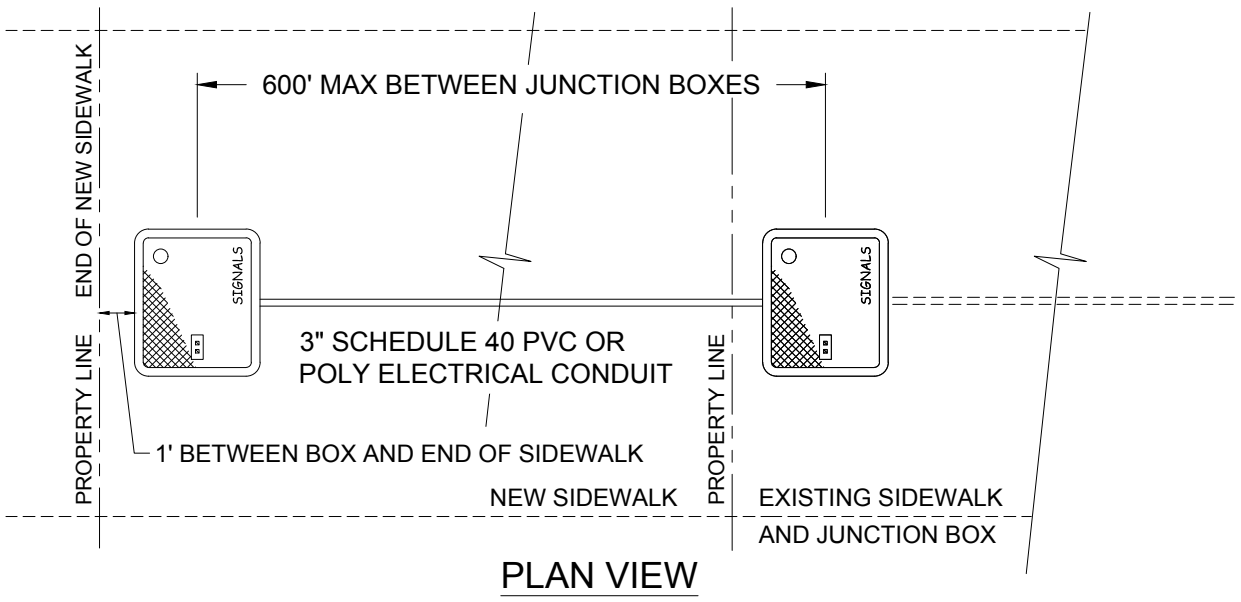

PLAN VIEW

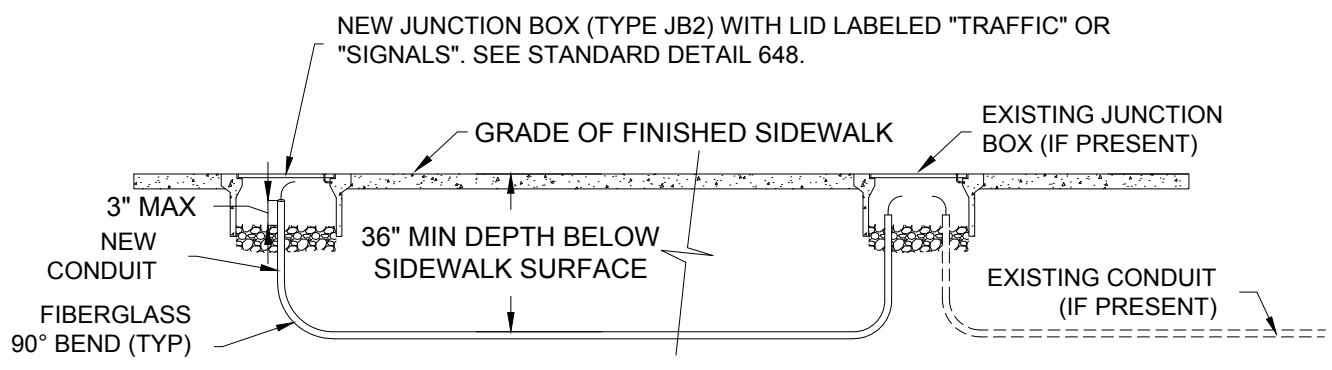

PROFILE VIEW

NTS

NOTES:

1. INSTALL PULL LINE (MIN STRENGTH 500 LB) AND CONTINUOUS #14 AWG XHHW LOCATE WIRE IN CONDUIT.
2. INSTALLATION REQUIRES SUPERVISION BY LICENSED ELECTRICIAN.
3. CONDUIT MATERIALS SHALL MEET REQUIREMENTS OF SECTION 02920 OF ODOT STANDARD SPECIFICATIONS FOR CONSTRUCTION UNLESS OTHERWISE DIRECTED.
4. JUNCTION BOX COVERS TO HAVE LEGEND "SIGNALS" STAMPED OR EMBOSSED AND SHALL MEET ALL REQUIREMENTS OF SECTION 02920.14 OF ODOT STANDARD SPECIFICATIONS FOR CONSTRUCTION.
5. PLACE ALL CONDUIT UNDER SIDEWALK OR AS DIRECTED.
6. ALL CONDUITS MUST BE TERMINATED IN TYPE 2 JUNCTION BOXES AND ARE TO BE INSTALLED PER REQUIREMENTS OF SECTION 00960 OF ODOT STANDARD SPECIFICATIONS FOR CONSTRUCTION.
7. IF SIDEWALK FRONTING ADJACENT PROPERTY HAS A SIGNAL JUNCTION BOX IN NEAREST SIDEWALK PANEL, EXCAVATE UNDER OLD SIDEWALK AND END NEW CONDUIT RUN IN EXISTING JUNCTION BOX. OTHERWISE TERMINATE NEW CONDUIT RUN IN NEW JUNCTION BOX IN LAST PANEL OF NEW SIDEWALK.

	<p>SIGNAL COMMUNICATIONS CONDUIT</p> <p>PWS VERSION: JULY 2026</p>	<p>DRAWN JG</p>
		<p>REV. DATE JAN 2019</p>
		<p>APPR.</p>
		<p>DETAIL NO. 651</p>