

# Appendix G: Stormwater Facility Planting

Public and private stormwater facilities require vegetation to be added after the blended soil has been added. Plants that can be planted in stormwater facilities are listed in the **Gresham List of Stormwater Plants**. The list provides specific information about the appropriate planting zone (see **section G.1**), whether plants are native to the Pacific Northwest, evergreen or deciduous, height at maturity, as well as whether they are appropriate for private facilities, or ones that will be publicly owned and/or maintained projects.

The list of approved plants for public facilities within the right-of-way is limited to those the City knows will survive in street-side facilities. Because these facilities get very hot and dry in the summer, the goal is to utilize plants that survive in the summer, while also being easy to prune and maintain for City staff or contracted crews.

## G.1 Planting Zones

Stormwater facilities have different moisture levels, depending upon facility design. Zone A is the most common moisture zone type (e.g. bottom area of a stormwater planter or rain garden). Zone S is the least frequent moisture zone, as these really only exist in wet ponds or centralized facilities with year-round flow. Zone B plants should only be selected if the proposed facility will actually have areas that are above an area that will be inundated when stormwater fills a facility.

The plant list categorizes allowable plants by the following moisture zones:

- **Zone A:** Uniformly wet to moist, facility bottom up to high water mark or overflow structure; aerobic and anaerobic soils
- **Zone A/B:** Broad range of moisture from moist to dry; aerobic soils
- **Zone B:** Drier transitional zone, generally above the high-water mark or overflow structure; aerobic soils
- **Zone S:** Wet or saturated, standing or flowing water with nearly constant saturation, and permanent pool; anaerobic soils.

**Figure G-1** provides a general overview of moisture zones in typical stormwater facility types. Site conditions such as inlets, outlets, flow path, slopes, and elevations will also affect moisture conditions.

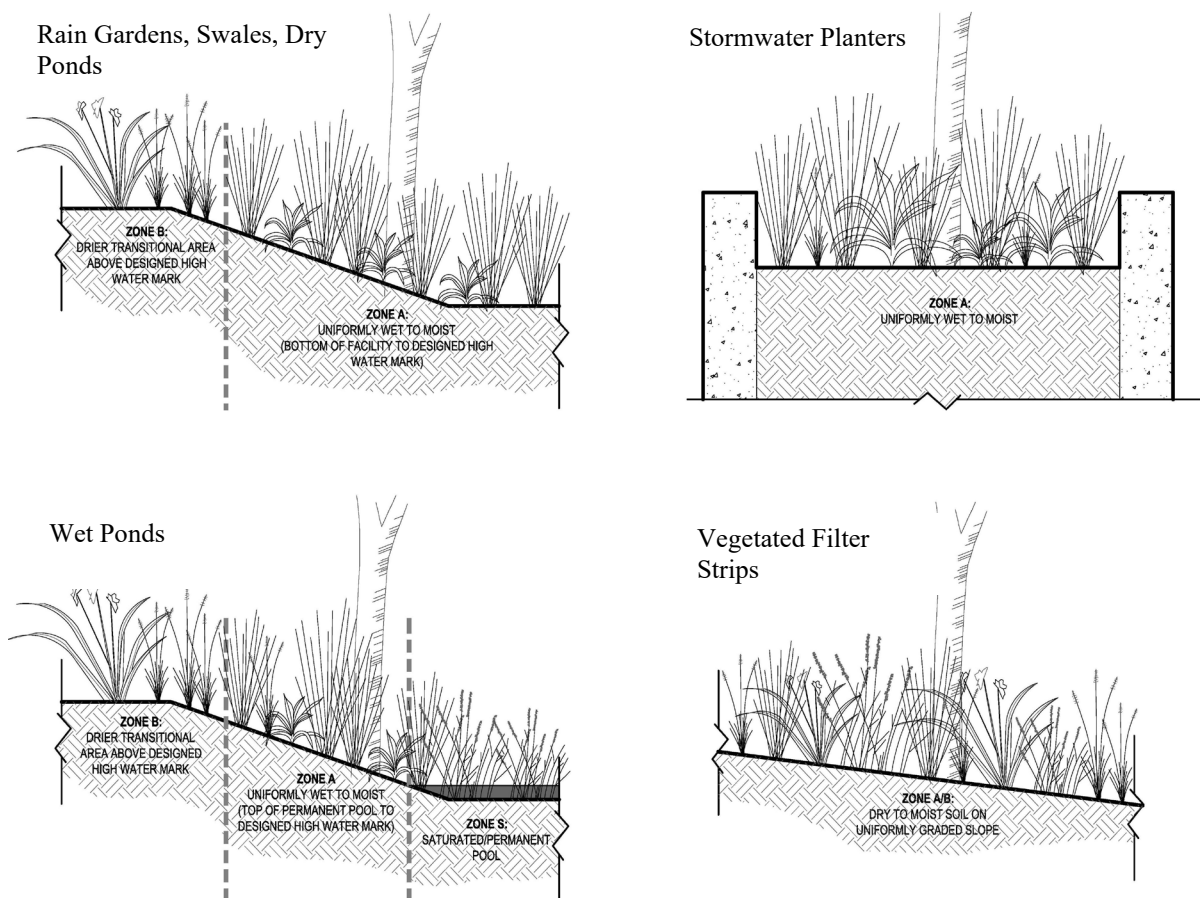

**Figure G-1.** Planting Zones by Facility Type (Figure from Clackamas County Water Environment Services)

## G.2 Plant Selection Considerations

The plants that can be installed in stormwater facilities is contained in the **Gresham List of Stormwater Plants**. The list is extensive, but focuses on plants that do well in the different zones described in **section G.1**. The large variety of plants available, particularly for private facilities, allows for a planting plan that can be customized to fit site function and aesthetics. For a natural aesthetic, species are often arranged in irregular clusters and groupings. For a manicured aesthetic, regular patterns are often used. Regardless of plant arrangement, the following general plan criteria must be followed.

- Plantings should consider flow patterns of water flowing through a facility. Plantings which have each row off-set are less likely to develop preferential flow paths.
- Like-species should be arranged together in groups of 3 or more; and larger facilities are well-suited for larger clusters of like-species
- All zones must have a minimum of 50 percent evergreen plants
- Integrate herbaceous evergreen species throughout the entire facility for increased filtration and evapotranspiration during the rainy winter months

- Plants that are dormant in the winter (i.e. bulbs and perennials) may be used as accent plants for visual interest, but may not be counted toward minimum plant densities for water quality function
- Select plants with consideration for growing habits, and long-term pruning and maintenance requirements
- If trees or large shrubs are planted, they should generally be placed along the north side of a facility to minimize shading of the lower growing emergent vegetation
- Facilities less than 3 feet wide should not use plants that are too large and will outgrow facilities or have the potential to cause root damage
- Lined facilities should not use large plant material (shrubs, trees) or plants with aggressive roots
- Parking areas should not impact required line of sight visibility
- Plants in street side facilities cannot impact required line of sight visibility
- Facilities adjacent to buildings and structures should not use plants that impact building footings, windows, retaining walls, culverts, underground pipes and utilities, or other structures
- Berms over four feet tall that impound water cannot have large trees or shrubs
- Stormwater facilities constructed within a Natural Resource Overlay must only use native vegetation.

### G.3 Plant Size Requirements

Minimum size is one gallon (#1) container pots for all plants.

**Table G-1.** Plant spacing by facility type and zone:

Facility Type	Planting Zone	Plant size	Spacing <sup>1</sup> Public / Private
Stormwater Planter	A	1 gallon	12" / 15"
Rain Garden/Swale <sup>2</sup>	A and B	1 gallon	12" / 15"
Dry Pond and Subsurface Gravel Pond	A	1 gallon	15" / 15"
	B	Seed	Follow label for coverage
Wet Pond <sup>3</sup>	A	1 gallon	15" / 15"
	B	Seed	Follow label for coverage
	S	1 gallon	15" / 15" (unless permanent pool >18" deep)
Filter Strip	A/B	Seed	Follow label for coverage

<sup>1</sup>On center (O.C.) spacing

<sup>2</sup>Swales within the right-of-way that intend to use trees as the primary vegetation require trees to be planted every 25-feet (or other spacing if recommended by city) and may use turf grass between trees.

<sup>3</sup>If permanent pool depth in zone S will be deeper than 18 inches, no planting required on pond bottom, otherwise plant spacing in zone S shall be 15" O.C. Wet ponds shall add 1-gallon plants 15" on-center to the first 4-feet of zone A (above the permanent pool elevation).

- Public facilities within the right-of-way shall have plants be spaced 12" on center (O.C.)
- Private rain gardens and planters shall be spaced according to the notes on the typical detail (see **Appendix H**). In general, the spacing for plants in these facilities is 15" O.C. Facilities where accent plants, shrubs or trees are included will have different spacing requirements. For example:

- Zone A (wet): 80 herbaceous plants per 100 sf, or 72 herbaceous plants and 4 small shrubs
- Zone B (moderate to dry): 7 large or small shrubs and 70 groundcover plants per 100 sf
- Private or public ponds/centralized facilities shall have gallon sized (#1) plants spaced 15" O.C. for zone A. Zone A extends one vertical foot up from the bottom of dry ponds and subsurface gravel ponds, and one vertical foot up from the permanent pool elevation of wet ponds.

If trees have been approved for use in stormwater facility, minimum size is 2" caliper. Note that trees shall not be added over any portion of a facility where a rock/drain layer has been installed.

The **Gresham List of Stormwater Plants** contains a list of plants approved for use in green roof/ecoroofs. The planting density expected for an ecoroof is 90% cover after the establishment period; no on-center spacing requirement is provided.

## G.4 Plant Installation

Ponds/centralized facilities that are used during the construction phase as a temporary sedimentation basin should delay placing soil/growing medium or install permanent vegetation after the facility is done being used for erosion control. Sediment removal, growing media replacement and/or vegetation replacement may be required prior to city acceptance of any facility finished prior to the construction phase being complete.

Weather permitting, plants shall be installed as soon as possible after placing and grading the stormwater soil in order to minimize erosion and compaction. For optimal plant survival, planting should be completed in the late summer or early fall.

## G.5 Plant Maintenance and Guarantee

### PRIVATELY OWNED AND MAINTAINED FACILITIES:

Plants within privately owned facilities, such as rain gardens and stormwater planters, on private property are the sole responsibility of the property owner to maintain.

### FACILITIES THAT WILL BE PUBLICLY OWNED OR MAINTAINED:

Stormwater facilities that will be publicly owned or maintained have a 2-year guarantee that is outlined in the *Public Works Standards*. The intent is to have well established plants that require less care following the 2-year establishment period. Plants must survive the first two years after planting before becoming public maintenance responsibility, so watering, weeding, mulching and replanting during the first 2 years are the responsibility of the private party installing the public infrastructure.

Any contractor or developer constructing vegetated facilities which will be publicly owned or maintained is responsible for maintaining all site stormwater management features during the 2-year maintenance warranty period in accordance with PWS 209.03.04 Plant Guarantee and Maintenance. This includes maintaining, repairing, and/or replacing plants and/or trees; any structural or functional repairs; and the maintenance of the facility, which includes: hand removal of undesirable or "weedy" vegetation, mowing, pruning, mulching, and regular summer irrigation.

During the establishment period, the party responsible for maintenance is required to, at a minimum:

- Inspect the facilities monthly;
- Remove any garbage, sediment, or weeds within one week of monthly inspection;
- Replace any dead or missing plants within one month\*;
- Water plants and trees, as needed.

\*monthly plant replacement not required July through September, but plants should be replaced before October 15.

Failure to demonstrate that all of the above activities and timelines were adhered to during the establishment period may result in an extension of the 2-year guarantee period.



The City will provide inspection and some general maintenance (e.g. sediment and garbage removal) during the warranty period, but because maintenance related to weeds, soil, mulch and plant pruning might affect the survival of plants, City personnel will not perform maintenance activities, or arrange for contractor-performed maintenance, during the 2-year warranty period unless the developer has entered into an agreement to compensate the City for taking on this work.

## G.6 Planting Template for Stormwater Facilities Within Public ROW

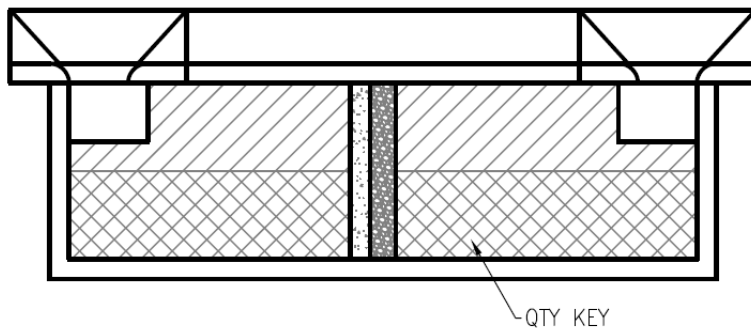
TEMPLATE 1





PLANT LEGEND 1

SYMBOL	BOTANICAL NAME COMMON NAME
	JUNCUS PATENS SPREADING RUSH
	CAREX OBNUPTA SLOUGH SEDGE

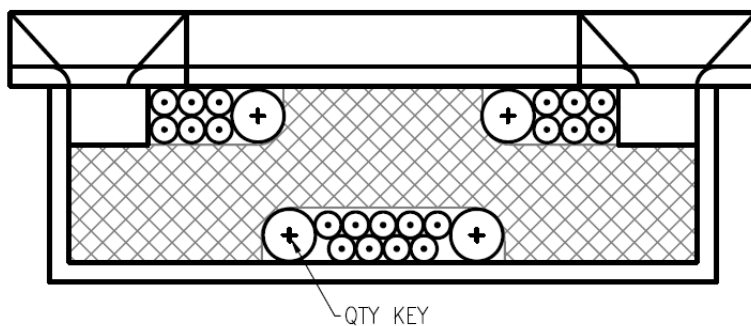
TEMPLATE 2



PLANT LEGEND 2

SYMBOL	BOTANICAL NAME COMMON NAME
	JUNCUS PATENS SPREADING RUSH
	CAREX OBNUPTA SLOUGH SEDGE
	SPIRAEA JAPONICA 'GOLD MOUND' GOLDMOUND JAPANESE SPIREA

**Figure G-2.** Planting template options for stormwater planters located within public ROW. These templates may be modified using other plants listed as approved for use within ROW from the **Gresham List of Stormwater Plants**. The template is included as standard detail GS-113 in the Gresham *Public Works Standards*.