

# Appendix C: Erosion Prevention and Sediment Control Manual

Land disturbance increases the potential for soil erosion, which can enter the City's stormwater system and harm local water bodies. The City of Gresham requires erosion prevention and sediment control on all land-disturbing activities.

This manual outlines the requirements for Erosion Prevention and Sediment Control (EPSC) and other activities to prevent stormwater pollution due to construction activities.

The authority for this Manual is derived from the Gresham Community Development Code (GCDC) and the Gresham Revised Code (GRC).

## C.1 Applicability

- The City of Gresham requires erosion prevention and sediment control on all land-disturbing activities, regardless of whether that property is involved in a construction or development activity.
- Construction activities disturbing 1,000 square feet or more will be subject to EPSC inspection procedures. At the City's discretion, permitted development less than 1,000 square feet may also be inspected.
- Construction sites disturbing more than one acre, or are part of a common plan of development that will ultimately disturb one or more acres, are required to obtain a DEQ 1200-C Construction Stormwater Permit. If City staff become aware of a project subject to DEQ 1200-C requirements, staff will inform the project owner of the requirement and will refer the project to DEQ within 7 days of making such a determination.

## C.2 Prohibitions

The discharge of sediment laden water from a construction site is a violation of the Gresham Revised Code Article 3.23.025, and is subject to the enforcement actions listed in section C.8.

## C.3 Requirements

***No work shall be conducted prior to EPSC Plan approval.***

The owner, agent, contractor, or employee shall:

- Develop and submit an EPSC Plan at the same time as the building permit application
- Properly install, operate and maintain best management practices (BMPs) to protect the environment during the useful life of the project.

Approval of an EPSC Plan does not relieve the applicant's responsibility to ensure that erosion prevention and sediment control measures are constructed and maintained to contain sediment on the construction site.

Land disturbing activities not required to obtain an EPSC permit are required to utilize EPSC measures if sediment is leaving or has the potential to leave site.

## C.4 Minimum Site Requirements

The owner or agent shall indicate how the following requirements are addressed in the development of the EPSC Plan submitted to the City for review.

### **Requirement #1: Preserve Vegetation/Mark Clearing Limits**

- Phase work to avoid disturbing more land than needed
- Before beginning land disturbing activities, including clearing and grading, clearly mark all clearing limits, sensitive areas and their buffers, and trees that are to be preserved within the construction area. Trees within environmental protection areas (HCA/ESRA) are to be protected. Temporary fencing shall be placed around the dripline of all trees and vegetation to be protected.
- Retain the duff layer, native topsoil, and natural vegetation in an undisturbed state to the maximum degree possible.

### **Requirement #2: Construction Entrance Protection**

- Limit construction vehicle access and exit to one route, if possible.
- Stabilized surfaces shall be of sufficient length/width to provide vehicle access/parking, based on lot size/configuration.
- Stabilize access points with a pad of quarry spalls, crushed rock, or other equivalent BMPs, to minimize tracking sediment onto roads.
- If sediment is tracked off site, clean the affected roadway thoroughly at the end of each day, or more frequently as necessary. Remove sediment from roads by shoveling, sweeping, or pick up and transport the sediment to a controlled sediment disposal area.
- Conduct street washing only after sediment is removed in accordance with the above bullet.
- Control street wash wastewater by pumping back on site or otherwise preventing it from discharging into stormwater system or watercourse.

### **Requirement #3: Perimeter Control**

- Maximize erosion protection and minimize sediment transport from disturbed ground surfaces.
- The design, installation and maintenance of erosion and sediment controls must address factors such as the amount, frequency, intensity and duration of precipitation, the nature of resulting stormwater runoff, and soil characteristics.

### **Requirement #4: Storm Drain Inlet Protection**

- Protect all storm drain inlets so that stormwater runoff does not enter the conveyance system without first being filtered or treated to remove sediment.
- Clean or remove and replace inlet protection devices when sediment has filled one-third of the available storage.
- Keep all approach roads clean. Do not allow sediment or street wash water to enter storm drains.
- Inlets should be inspected weekly at a minimum and daily during storm events.

### **Requirement #5: Soil and Slope Protection**

- Minimize the amount of soil exposed during construction activity.
- Minimize the disturbance of steep slopes.
- Stabilize exposed and unworked soils by application of effective BMPs that prevent erosion.
  - During the wet season (October 1 - April 30): within 2 days
  - During the dry season (May 1 - Sept. 30): within 7 days
- Control stormwater volume and velocity within the site to minimize soil erosion.

- Stabilize soils at the end of the shift before a holiday or weekend if needed based on weather forecast.
- Establish temporary vegetation during construction and permanent vegetation when completed.

**Requirement #6: Control Runoff (may not apply for detached dwelling units and middle housing)**

- Divert stormwater or ground water away from slopes and disturbed areas with diversion/interceptor dikes, pipes, and/or swales.
- Place check dams at regular intervals within constructed channels that are cut down a slope.
- Dissipate energy of any diverted water.

**Requirement #7: Sediment Containment and Removal (may not apply for detached dwelling units and middle housing)**

- Direct stormwater runoff from disturbed areas through vegetation, a sediment pond or other appropriate sediment removal BMP, before the runoff leaves site.
- Withdraw ponded stormwater from the surface to avoid discharging sediment, or use filtration during dewatering to avoid discharging sediment.

**Requirement #8: Soil Stockpile Management (may not apply for detached dwelling units and middle housing)**

- Locate temporary stockpiles at least 50 feet away from inlets, drainage courses, or water bodies.
- Stockpiles shall be seeded, mulched, or covered with plastic sheeting within the following time periods:
  - During the wet season (October 1 - April 30): within 2 days
  - During the dry season (May 1 - Sept. 30): within 7 days
- Stabilize soils at the end of the shift before a holiday or weekend if needed based on the weather forecast.

**Requirement #9: Construction Site Pollution Prevention**

- Do not dump excess concrete into storm drains, open ditches, streets, or streams; if it is rinsed out on-site, keep it in a designated concrete washout area.
- Store all chemicals, fuels, and materials in a designated area at least 50 feet from stormwater inlets, and provide secondary containment for hazardous materials
- Ensure portable toilets are placed off pavement if possible, and are secured to keep upright in areas of high wind.

## C.5 Best Management Practices to Meet Minimum Requirements

**Table C-1** contains a list of approved Best Management Practice (BMP) measures. One or more of the listed BMPs, or their equivalent if approved by EPSC Program Manager, shall be used to meet the minimum requirements outlined in the previous section. Each BMP shall be implemented consistent with the information in the BMP Fact Sheets (**Section C.10**) and the Standard Detail (**Section C.11**) portions of this manual.

**Table C-1. Minimum BMPs for All Construction Projects**

BMP Code	BMP Name	BMP Fact Sheet Page	Standard Detail
<b>Requirement 1: Preserve Vegetation/Mark Clearing Limits</b>			
EPSC-1	Scheduling	C-9	-
EPSC-2	Preservation of Existing Vegetation/Buffer Strips	C-10	EPSC-2
<b>Requirement 2: Construction Entrance Protection</b>			
EPSC-3	Construction Entrance/Exit Tracking Controls	C-11	EPSC-3
<b>Requirement 3: Perimeter Control</b>			
EPSC-4	Sediment Fence	C-12	EPSC-4
EPSC-5	Fiber Rolls/Wattles	C-13	EPSC-5
EPSC-6	Compost Berm/Sock	C-14	EPSC-6
EPSC-7	Undercut Lots/Sidewalk Subgrades	C-15	EPSC-7
<b>Requirement 4: Storm Drain Inlet Protection</b>			
EPSC-8	Storm Drain Inlet Protection	C-16	EPSC-8A EPSC-8B
<b>Requirement 5: Soil and Slope Protection</b>			
EPSC-9	Surface Roughening	C-17	EPSC-9
EPSC-10	Hydroseeding, Mulching and Tackifiers	C-18	EPSC-10
EPSC-11	Erosion Blankets and Mats	C-19	EPSC-11
EPSC-12	Seeding and Planting (Temporary and Permanent)	C-20	-
EPSC-13	Wind Erosion/Dust Control	C-21	-
<b>Requirement 6: Control Runoff (may not apply for detached dwelling sites)</b>			
EPSC-14	Slope Drain	C-22	EPSC-14
EPSC-15	Energy Dissipation/Outlet Protection	C-23	EPSC-15
EPSC-16	Diversion Dikes/Swales	C-24	EPSC-16
EPSC-17	Check Dams	C-25	EPSC-17A EPSC-17B EPSC-17C
<b>Requirement 7: Sediment Containment and Removal (may not apply for detached dwelling sites)</b>			
EPSC-18	Temporary Sediment Basin	C-26	EPSC-18
EPSC-19	Dewatering and Poned Water Management	C-27	-
<b>Requirement 8: Soil Stockpile Management (may not apply for detached dwelling sites)</b>			
EPSC-20	Soil Stockpile Management	C-28	EPSC-20
<b>Requirement 9: Construction Site Pollution Prevention</b>			
EPSC-21	Concrete Management	C-29	EPSC-21
EPSC-22	Materials Management	C-30	-
EPSC-23	Sanitary Waste Management	C-31	-

## C.6 Maintenance and Removal of BMPs

- The permittee shall maintain the Erosion Control BMP measures and apply the techniques contained in the approved EPSC Plan during: the construction phase, post construction phase, establishment of permanent vegetation, or any other permitted activity.
- When sediment is captured by BMPs so that it fills 1/3 height, 50% of the capacity, or is deposited in locations where it can enter the storm and surface water system, the sediment shall be immediately removed.
- No sediment shall be washed or flushed into any part of the storm and surface water system until all mechanical means to remove the sediment have been exhausted and preventative sediment measures, e.g., inlet protection, is in place.
- If the BMP measures and techniques approved in an EPSC Plan are not effective or sufficient as determined by the permittee or City, the permittee shall submit a revised plan within three working days of notification by the City. Upon approval of the revised plan by the City the permittee shall immediately implement the additional measures and techniques included in the revised plan. In cases where erosion is likely to occur, the City may require the applicant to install interim control measures prior to submittal of the revised EPSC Plan.
- Temporary BMPs, such as sediment fences, shall be removed after permanent vegetation is established but not before all construction activities on the site are completed.

## C.7 Inspection

### C.7.1 Pre-Construction Conference

Prior to the initial EPSC inspection, the City, Permittee, Owner, or Contractor may request, a pre-construction meeting to review and discuss the EPSC plan for the site.

A pre-construction conference shall be required when the risk of erosion is high due to one or more of the following factors:

- Wet weather construction.
- Steep slopes with severe erosion potential.
- Construction adjacent to a sensitive area or vegetated corridor.
- Mass grading on a large site.

### C.7.2 City Initial EPSC Inspection

On all projects, erosion prevention and sediment control base measures shall be installed by the permittee and then inspected and approved by the City inspector prior to the start of any permitted activity (e.g. clearing and grading). For detached dwelling construction sites, erosion prevention and sediment control measures for each property shall be installed by the permittee and then inspected and approved by the City inspector prior to the building foundation installation. Foundation approvals shall not be given until erosion prevention and sediment control measures are approved.

### C.7.3 Permittee Inspections

The permittee shall inspect the EPSC measures and provide maintenance as required to maintain the functionality of the BMP measures. Minimum inspection frequency requirements are:

- Daily when stormwater runoff, including runoff from snow melt, is occurring
- Once per week on active sites when runoff not occurring

- Once every two weeks on inactive sites

### C.7.4 Interim Inspections

Routine erosion control inspections conducted by the City will be performed at the discretion of the City throughout the building permit process.

### C.7.5 Final Inspection

A final erosion control inspection shall be required on all sites prior to issuance of a Certificate of Occupancy. Final Inspection requirements are:

- Removal of EPSC measures, unless needed to prevent movement of sediment or pollutants off-site
- All bare soil protected with permanent vegetation or 2" layer of landscaping bark mulch

DEQ may have additional requirements in order to terminate a NPDES 1200-C Permit.

## C.8 Compliance and Enforcement Action

Violations of the erosion prevention and sediment control requirements will be enforced per Gresham Revised Code and/or ODEQ regulations. Enforcement actions for sites not making corrective actions within the period provided by the City inspector include, but are not limited to:

- Charging re-inspection fee,
- Issuance of a Stop Work Order,
- Civil Penalties based per violation per day, and/or
- Abatement to correct EPSC measures.

The City may take enforcement action for any of the following criteria:

- Failure to repair or install BMPs according to the City Inspectors directive (written or verbal) within the specified timeframe.
- If one pound or more of sediment (wet weight) yield per acre is discharged from a construction site in a single day, the City may require additional BMPs or levels of BMP implementation at the site. This is based on the average daily amount of soil loss predicted by the Revised Universal Soil Loss Equation (RUSLE).
- Visible turbid runoff into stream due to construction activity.
- Failure to respond, contain, or cleanup any other spills or discharges that are capable of polluting stormwater.

## C.9 EPSC Plan Development

The City reviews and approves several different types of development activities, such as Detached Dwelling and Middle Housing, Commercial, Industrial, Land Partitions, and Subdivisions. Depending on the type of development and the area of disturbance, the City will review, approve and issue an Erosion Control Permit. Below are the requirements for EPSC Plans submitted to the City.

### C.9.1 Single-Family/Duplex EPSC Plan

Detached home sites which disturb less than 1 acre shall prepare an EPSC plan for all sites where an Erosion Control Permit is required.

For detached dwelling permit applications, the applicant will apply for the erosion control permit along with the building permit application.

The following checklist constitutes the Detached Dwelling EPSC site plan:

- Site plan that includes:
  - Contours and/or drainage patterns found on the site—identify any slope greater than 5%.
  - Location of erosion prevention and sediment control measures to be used on site\*. Including but not limited to:
    - Gravel construction entrance
    - Perimeter control downslope side of the site along contours
    - Storm drain/catch basin inlet protection
    - Soil/stockpile management
    - Concrete, materials and sanitary waste management
- Completed EPSC Checklist, including name and phone number of the person(s) responsible for erosion prevention and sediment control on site.

*\*Between October 1 and May 31 notes describing additional wet weather BMPs to be utilized for soil and slope protection.*

## C.9.2 Non-Residential EPSC Plan Process

Non-residential sites of less than 1 acre of disturbance shall follow the same Erosion and Sediment Control Plan templates as used for NPDES 1200-C permits.

The following is an outline of the process for submitting an EPSC plan to the City for review and approval.

### **The EPSC Plan submittal must include:**

- Cover sheet with a site location map.
- Proposed public and private stormwater system plan or composite utility plan.
- Final site stabilization or planting plan.
- Completed EPSC Site Plan (see below)

### **The EPSC Site Plan must include the following items:**

- Name and number of the designated person responsible for erosion control
- Contour lines with elevations included on the plan extending 200 feet beyond the property line
- Adjacent natural resources, such as, streams, creeks, wetlands, ponds, drainage channels, lakes, and other sensitive areas
- Identification of slopes, drainage patterns, and concentrated flows
- Location of cuts and fills
- Locations, specifications, details and/or standard notes for all required BMPs:
  - Requirement 1: Preserve Vegetation/Mark Clearing Limits
    - Scheduling/Phasing of work
    - Preservation of Existing Vegetation/Mark Clearing Limits
  - Requirement 2: Construction Entrance/Exit Tracking Controls
    - Construction Entrance/Exit Tracking Controls
  - Requirement 3: Perimeter Control
    - Sediment Fence
    - Fiber Rolls/Wattles

- Compost Berm/Sock
- Undercut Lots/Sidewalk Subgrades
- Requirement 4: Storm Drain Inlet Protection
  - Catch Basin Inlet Protection
  - Ditch/Field Inlet Protection
- Requirement 5: Soil and Slope Protection
  - Surface Roughening
  - Hydroseeding, Mulching and Tackifiers
  - Erosion Blankets and Mats
  - Seeding and Planting (Temporary and Permanent)
  - Wind Erosion/Dust Control
- Requirement 6: Control Runoff
  - Slope Drain
  - Energy Dissipation/Outlet Protection
  - Diversion Dikes/Swales
  - Check Dams
- Requirement 7: Sediment Containment and Removal
  - Temporary Sediment Basin
  - Dewatering and Poned Water Management
- Requirement 8: Soil Stockpile Management
  - Soil Stockpile Management
- Requirement 9: Construction Site Pollution Prevention
  - Concrete Management
  - Materials Management
  - Sanitary Waste Management
- BMP maintenance & inspection schedule
- Construction schedule

## C.10 BMP Fact Sheets

The following fact sheets provide a basic overview of each of the BMPs listed in Table C-1 to meet the minimum EPSC requirements. For technical drawings and/or notes about each BMP, see the EPSC Standard details.

## C.11 EPSC Standard Details

Standard details, including drawing and standard notes for each of the BMPs in Table C-1 are included in Table C-2 on page C-32.

## SCHEDULING – EPSC-1

### **Objective:**

Scheduling involves sequencing construction activities and the installation of erosion prevention and sediment control measures to reduce the amount and duration of soil exposed to erosion by wind, rain, runoff and vehicle tracking.

### **Installation:**

- Optimum grading period is when the chance for precipitation is minimized. If precipitation is likely during grading, minimize the length of time that soils are exposed, and the total area of exposure.
- Perform the following actions when precipitation is forecast:
  - Minimize the length of time that the soils are left exposed.
  - Reduce the total area of exposed soil.
  - Protect critical areas such as drainage channels, streams, and natural water courses.
  - Stabilize exposed areas quickly.
  - Ensure inlets are protected and protection measures maintained.
- The schedule shall include detail on the implementation of temporary soil stabilization measures, temporary sediment controls, tracking controls, wind erosion controls, non-stormwater pollution controls (including waste management and materials pollution controls).
- When rainfall is predicted, adjust the construction schedule to allow the implementation of soil stabilization and sediment control on all disturbed areas prior to the onset of rain.
- Keep the site stabilized year-round, and retain and maintain sediment trapping devices in operational condition. Erosion may be caused during dry seasons by unseasonable rainfall, wind, and vehicle tracking.
- Sequence trenching activities so that most open portions are closed before new trenching begins.
- Materials used for erosion and sediment control should be on site at all times.

### **Maintenance:**

- Minimize construction during rainy weather.
- Schedule projects to disturb only small portions of the site at any one time.
- Complete grading as soon as possible and immediately stabilize the disturbed portion before grading the next portion.
- Practice staged seeding in order to re-vegetate cut and fill slopes as the work progresses.

## PRESERVATION OF EXISTING VEGETATION/BUFFER STRIPS – EPSC-2



### Objective:

Maintaining existing vegetation or placing vegetative buffer strips can reduce runoff and erosion, filter out sediments and other pollutants, and provide protection for sensitive areas. Preserving existing trees on site can help provide habitat, shade and other stormwater benefits – but ensuring tree survival requires avoiding damage to the roots, trunk and canopy during construction.

### Installation:

- When perimeter vegetation is to be preserved, install orange safety fence immediately after construction limits have been determined. Orange poly fence with 2" x 2" max openings requires posts spaced no more than 4'.
- For trees being preserved, immediately install tree protection fencing per detail EPSC-2. Chain link fencing, a minimum of 4' in height, is preferred.
- Preserve as much of the natural landscape as possible.
- Preserve natural vegetation on unstable, steep slopes.
- Current regulatory buffer zone widths must be met around sensitive habitat areas.
- Protect trees and vegetation from:
  - Construction equipment both above and below ground level, including breakage, scarring, cutting roots or compaction of root zone.
  - Root exposure.
  - Damage caused by excavations for utility lines.

### Maintenance:

- Inspect fencing often to ensure that preserved areas remain clearly marked and fencing is properly located.
- Check for damage to surrounding vegetation.
- Remove the fences and barriers last, after final cleanup and landscaping is completed.

## CONSTRUCTION ENTRANCE/EXIT TRACKING CONTROLS – EPSC-3



### **Objective:**

Stabilized construction entrance and exit help to prevent the tracking of soil onto public or private roadways that could flow into stormwater conveyance systems or surface waters.

### **Installation:**

- Stabilize entrance/exit prior to any site work.
- Minimum length should be 20 feet on detached dwelling and middle housing sites and 50 feet for all other sites
- Width shall not be less than width of all points of ingress and egress, with minimum width of 20 feet
- Depth shall be 8 inches
- The aggregate size for construction of the pad shall be 3/4 inch rock for detached dwelling and middle housing construction and 3-6 inch rock for other development.
- Use only washed rock to minimize sediment runoff.
- All sediment tracked onto public rights-of-way shall be removed as soon as possible by hand sweeping, mechanized sweeper, or vacuum. Washing of sediment from the public right-of-way shall be prohibited.

### **Maintenance:**

- Immediately sweep up and remove rock or sediment carried from the site. Stabilize onsite sediment generation areas to prevent tracking onto pavement.
- Do not flush rock or sediment from the site into the stormwater system.
- Add or replace rock as needed to maintain specified dimensions.

## SEDIMENT FENCE – EPSC-4



### Objective:

A sediment fence is a perimeter control consisting of filtering geotextile fabric secured between and attached to support posts. A sediment fence is a temporary measure used to intercept and filter sediment-laden runoff.

### Installation:

- Install as far away from toe of slope as possible in order to maximize storage area.
- Do not place sediment fence in or across streams, channels, or ditches.
- Proper installation and use prevents sediment-laden runoff from flowing beneath, through or over the sediment fence.
- Sediment fence shall have manufactured stitched loops with 4-foot long 2-inch x 2-inch posts. Stitched loops shall be installed on the uphill side of the slope.
- Bury the lower 6 inches of fabric in a trench along the contour. Backfill trench and compact the soil on both sides of the fence.
- When joining two sections of sediment fencing together, connect the two end stakes by wrapping them together at least one and a half turns and driving the joined stakes into the ground.
- At the end point of a sediment fence, angle the fence slightly uphill for one full 6-foot panel.

### Maintenance:

- Inspect frequently and immediately repair or replace split, torn, slumping, or weathered fabric.
- Remove sediment when accumulation reaches 1/3 the fence height. Incorporate sediment into the project site and stabilize or dispose of properly offsite.
- Remove sediment fence when the upslope area has been stabilized. Fill and compact post holes and anchorage trench, remove sediment accumulation, and grade fence alignment to blend with adjacent ground.

## FIBER ROLLS OR WATTLES – EPSC-5



### **Objective:**

Wattles are used primarily to intercept sheet and rill erosion on slopes. Wattles can be left in place as permanent landscape, or used as a bio-technical slope application. Wattles create a favorable environment for plant establishment by interrupting the slope length, trapping soil and moisture.

### **Installation:**

- Wattles should be made from rice straw, wood, or coconut fiber, placed inside plastic netting.
- Dig trench approximately 1/3 the diameter of the wattle.
- Use  $\frac{3}{4}$  x  $\frac{3}{4}$  inch stakes every 4 feet on center
- When spaced on contour, off-set joints on each uphill installation.
- When used for slope stabilization, live willow can be used as stakes and permanent landscaping can be installed while leaving wattles in place

### **Maintenance:**

- Make sure wattles are in contact with the soil and stakes are holding.
- Check for gaps at all joints.
- Immediately replace torn or damaged wattles.
- Clear accumulated sediment frequently so wattle is not breached.

## COMPOST BERMS AND SOCKS – EPSC-6



### Objective:

A compost filter berm is a trapezoidal berm applied by a blower, and a compost sock is compost material encased in mesh to form a tube or roll. Both techniques intercept sheet flow and pond runoff, allowing sediment to fall out of suspension, and often filtering sediment as well. Compost berms and socks provide an environmentally-sensitive and cost-effective alternative to sediment fence.

### Installation:

- Compost barriers shall only be used at the base of slopes 2H:1V or less.
- Compost needs to be stable and mature.
- The recommended moisture content ranges from 20-50%. Compost that is too dry is harder to apply, while that which is too wet is heavier and harder to transport.
- Compost must be weed and pesticide free, with manmade materials comprising less than 1%.
- Check for undercutting or piping under compost barrier.
- Inspect for channel formation parallel to the berm, which indicates it is acting as a flow barrier.
- Remove sediment accumulation when it reaches one-third of the barrier height.
- Compost berms and socks can be seeded during application. Do not cover seed with more than 2-4 inches of compost.
- Tackifiers may be applied to berms if needed to enhance performance.

### Maintenance:

- Compost barriers shall be inspected frequently and reapplied if necessary.
- Berms can be left on-site and seeded, or spread out in place as a soil enhancement

## UNDERCUT LOTS/SIDEWALK SUBGRADES – EPSC-7



### **Objective:**

Undercut lots or sidewalk subgrades provide an effective sediment filtration and retention on sites with no slope.

### **Installation:**

- Only appropriate on flat sites. Do not use if site has visible slope to street.
- Site must have street with curbs
- Sidewalk subgrade must have a minimum 4-inch depth and 4-foot width.
- Place a 2-inch layer of aggregate sub-base.
- Weep holes in curb must be plugged.
- If sidewalk is to be poured prior to site stabilization, alternative sediment barriers must be installed.

### **Maintenance:**

- Inspect weekly, and prior to and after rain events.
- Maintain as needed.
- Remove accumulated sediment and replace aggregate when filtering capacity is reduced by 50 percent or aggregate is clogged with sediment.
- All sediment must be removed from gravel subgrade and replaced with clean rock prior to pouring sidewalk

## STORM DRAIN INLET PROTECTION – EPSC-8



### Objective:

Temporary inlet protection must be provided for all active inlets for the duration of construction to keep sediment, trash, and other construction-related pollutants out of the storm drain system.

### Installation:

- Provide protection for all storm drain inlets adjacent to and within 500 feet of construction site.
- Both inlet inserts and barriers must be used at any catch basin that may receive runoff from construction activity.
- Installation of insert protection must not block flow from filtering into the inlet or catch basin.
- Curb inlet protection devices are required in addition to inlet inserts where recessed curb inlets are present.

### Maintenance:

- Accumulated sediment and debris must be removed from inlet insert when one-third the insert storage area is reached.
- Inspect all inlet protection devices before and after every rain event and weekly at active construction sites. During extended rain events, inspect inlet protection devices at least every 24 hours.
- Inspect the storm drain inlet for bypassed material after severe storms during the rainy season.
- Inlet protection must be removed and catch basin cleaned prior to project finalization.

## SURFACE ROUGHENING – EPSC-9



### **Objective:**

Surface roughening provides horizontal depressions or grooves that will trap seed and reduce run-off velocities. Roughening also reduces the length and steepness of slope. Roughening can be accomplished by ‘track walking’ slopes with tracked equipment, by using a serrated wing blade attached to the side of a bulldozer, a sheepsfoot roller, or by other agricultural equipment.

### **Installation:**

- Tracking is generally installed on 3:1 slopes or less, but may be installed on steeper slopes with additional sediment barriers.
- Surface roughening must run up and down the slope.
- Immediately seed and mulch area for optimum germination.
- Divert all concentrated run-off around treated area.

### **Maintenance:**

- Check the seeded slopes for signs of erosion such as rills and gullies. Fill these areas slightly above the original grade, then reseed and mulch as soon as possible.

## HYDROSEEDING, MULCHING, AND TACKIFIERS – EPSC-10



### Objective:

Hydraulic applications are a mechanical method of applying a homogenous slurry of material onto bare soil in order to establish erosion-resistant vegetation on disturbed areas and critical slopes. These erosion and dust control materials can often be applied in one operation. Mulching is the process of applying bulk materials to the soil surface to reduce rainfall impact, increase infiltration and, in some cases, aid in re-vegetation. Common types of mulch include vegetable fibers, green material, hydraulic mulches from recycled paper or wood fibers, straw mulch, and compost blankets.

### Installation:

- Divert concentrated run-off away from treated area.
- Seed, fertilizer, mulch, and tackifier can all be applied in a one step process.
- Exposed soils must be stabilized within the following periods:
  - During the wet season (October 1 - April 30): within 7 days
  - During the dry season (May 1 - Sept. 30): within 30 days
- Use liquid tacking agent for anchoring straw or as a dust control measure.
- Hydraulic applications should be applied in opposing directions in order to create a continuous uniform layer of protection.
- Allow for a minimum 24 hour curing time.
- If soil conditions are extremely dry, pre-water prior to application.

### Maintenance:

- Repair all damaged areas by applying additional material or matting.
- Check for 80% vegetative cover prior to wet weather season.

## EROSION BLANKETS AND MATS – EPSC-11



### **Objective:**

Erosion blankets or matting provides an immediate layer of protection from water or wind erosion. Matting can stop the impact of splash erosion, reduce run-off velocity, and force water infiltration. Matting can also promote seed germination by providing a thermal layer that retains moisture.

### **Installation:**

- Commonly used on 2:1 slopes or greater.
- Surface must be graded smooth prior to installation.
- Seed and fertilizer should be applied first.
- At the top of the slope, matting must be secured by burying in a trench
- Matting should be rolled down the slope and each roll should be overlapped according to manufacturer's instructions
- Matting must be in complete contact with the surface.
- Staples at top, bottom and along mats should be installed according to manufacturer's instructions

### **Maintenance:**

- Check condition of existing staples.
- Check surface to matting contact and add staples as needed.
- Repair or replace damaged matting.
- Check to make certain run-off is not flowing under matting at any point.

## SEEDING AND PLANTING (TEMPORARY AND PERMANENT) – EPSC-12



### Objective:

Seeding and planting consists of the establishment of vegetative cover on disturbed areas to protect soil surface and reduce erosion. Vegetative cover also promotes infiltration, traps sediment, and is effective for dust control.

### Installation:

- Exposed soils must be stabilized within the following periods:
  - During the wet season (October 1 - April 30): within 7 days
  - During the dry season (May 1 - Sept. 30): within 30 days
- Prepare site for seeding by fracturing and loosening the top 12 inches of soil and ensuring it is free of large clods or stones.
- Amend the soil by adding 3 inches of compost and incorporating it into the upper 8 inches. Compost must meet the requirements in SWMM **Appendix F**.
- In areas that will be seeded with turf grass, provide tackifier or light cover of mulch to protect seed, increase moisture, retention, and add a thermal layer. For permanent stabilization using turf, rolled sod may be installed over the amended soil.
- In areas that will be planting beds that are not covered by turf grass, a 2-4 inch layer of mulch following the requirements in SWMM **Appendix F** shall be used to cover the compost-amended soil.
- Divert all concentrated run-off around treated area.
- All seed shall be selected in accordance with City requirements, site conditions, and season.
- Sites located in Resource Areas or in a water quality facility that will be publicly owned or maintained require a City-approved native erosion control seed mix.
- If seeding is applied during the dry season (June 1 through September 30) or drought periods, irrigate seeds so that at least 80% ground cover is established by October 1.
- Apply seeding or sod so vegetative layer is established by start of the wet season (October 1 through May 31) or before freezing weather is anticipated.

### Maintenance:

- Check for damage due to concentrated runoff.
- Repairs may require prevention measures such as matting or sod.
- Check germination rate to make certain it reaches a minimum of 80% growth prior to wet weather period.

## WIND EROSION / DUST CONTROL – EPSC -13



### **Objective:**

Wind erosion control consists of preventative measures to reduce sediment transported by wind and deposited in water resources.

### **Installation:**

- Dust control shall be provided daily or more often (as deemed necessary based on wind conditions, time of year, and physical conditions of the site) by application of water alone or with addition of magnesium chloride or calcium chloride in accordance with manufacturer's specifications.
- Acrylic co-polymers or other biodegradable products (soil stabilizers/tackifiers) may be used for daily dust control if approved by the City.
- Water applied for dust control shall be applied evenly and without over watering, which generates runoff and may result in erosion by water.
- Oil or other petroleum-based products shall not be used for dust control.
- Dust control must be implemented in accordance with state air quality requirements.
- Keep stockpiles covered to minimize wind erosion.

### **Maintenance:**

- Check areas protected to ensure appropriate coverage.
- Reapply water or maintain covers, as necessary to be effective.

## SLOPE DRAIN – EPSC-14



### **Objective:**

Slope drains are used to intercept and direct surface runoff or groundwater into a stabilized watercourse, trapping device, or stabilized area.

### **Installation:**

- Place slope drains on undisturbed soil or well-compacted fill at locations and elevations shown on plans.
- Slightly slope the section of pipe under the dike toward its outlet.
- Compact the soil under and around the entrance section in lifts not to exceed 6 inches.
- Ensure that fill over the drain at the top of the slope has a minimum depth of 1.5 feet and a minimum top width of 4 feet. The sides should have a 3H:1V slope.
- Ensure that all slope drain connections are watertight.
- Ensure that all fill material is well-compacted. Extend the drain beyond the toe of the slope and adequately protect the outlet from erosion.
- Make the settled, compacted dike ridge no less than 1 foot higher than the top of the pipe inlet.
- Immediately after grading, stabilize all disturbed areas as appropriate.

### **Maintenance:**

- Inspect the slope drain and supporting diversions before, during, and after every storm event and promptly make necessary repairs.
- When the protected area has been permanently stabilized, remove the temporary measures, dispose of the materials properly, and stabilize disturbed areas appropriately.

## ENERGY DISSIPATION/OUTLET PROTECTION – EPSC-15



### Objective:

Outlet protection prevents scour at conveyance outlets and minimizes the potential for downstream erosion by reducing the velocity of concentrated stormwater flows. Outlet protection is required at the outlets of all ponds, pipes, ditches, and where runoff is conveyed to a drainage feature such as a stormwater facility, ditch, natural drainageway, stream, wetland, or lake. Any energy dissipation that will be installed within a Resource Area or discharging to a protected waterway must meet the requirements in SWMM **section 4.8**.

### Installation:

- Riprap should be inlaid into the soil a minimum of 1 times the diameter of maximum stone size, with a layer of geotextile fabric under rock.
- Depth of riprap should be 1.5 feet times the diameter of maximum rock size used.
- Length of apron should be long enough to prevent erosive velocities both at the outlet structure and downstream as well.
- Riprap should be placed above and around the sides of the outlet pipe to prevent erosion.
- Size of rock and installation shall follow the outlet protection guidance in the ODOT Hydraulics Manual.

### Maintenance:

- Check for scouring around riprap apron.
- Check for scouring downstream of structure.
- Remove accumulated sediment.
- If outlet structure is temporary, remove once permanent structure has been installed.

## DIVERSION DIKES AND SWALES – EPSC-16



### **Objective:**

Dikes and swales divert storm runoff from onsite and offsite drainage areas and direct flow to a sediment trap, pond, or other approved stabilized outlet. Dikes and swales may be installed as permanent site drainage control features, while providing conveyance of temporary development flows.

### **Installation:**

- Estimate flows from the drainage areas to be collected and conveyed by the dike or swale.
- Intercepted runoff shall be directed to a stabilized area such as a basin, trap, or other holding area. The diversion shall be designed so that no erosion occurs from the movement of the additional water volume and flow rate.
- Use check dams to control flow rate within dikes and swales.
- Outlet protection shall be provided to minimize erosion at dike outlet.
- Construction traffic over dikes and swales shall be minimized.

### **Maintenance:**

- Inspect after every major rainstorm for side and bottom inlet and outlet scour.
- Remove sediment and other debris when one-third of conveyance storage capacity is reached.
- Temporary dikes and swales shall be graded out at the completion of construction, when permanent vegetation has been established.

## CHECK DAMS – EPSC-17



### **Objective:**

Check dams reduce the velocity of concentrated flow in swales, dikes, or ditches. Check dams reduce erosion and act as a barrier trapping sediments and other site pollutants.

### **Installation:**

- Check dams shall be constructed of rock, fiber rolls, or filled compost socks.
- Rock check dams must be constructed of appropriately sized rock. The rock must be large enough to stay in place given the expected design flow through the channel.
- Place check dams perpendicular to the flow of water.
- Ensure that check dams are adequately keyed into side slopes to withstand flows and prevent washouts at ends.
- Check dams must be imbedded into channel bottom so that undercutting does not occur.
- Plan for adequate methods of sediment removal behind check dams and ensure that sufficient area for equipment access is available.

### **Maintenance:**

- Inspect check dams before, during, and after each rainfall event. Repair damage as needed.
- Remove sediment when depth reaches one-third the height of the check dam.
- Remove accumulated sediment prior to permanent seeding or soil stabilization.
- Remove check dam and accumulated sediment when check dams are no longer needed.
- Removed sediment shall be incorporated in the project or disposed of properly.

## TEMPORARY SEDIMENT BASIN – EPSC-18



### **Objective:**

Temporary sediment basins are used to collect and store sediment from sites cleared and/or graded during construction. Sediment basins, along with other perimeter controls, shall be installed before any land disturbance takes place in the drainage area.

### **Installation:**

- Sediment basin must be designed by a professional engineer licensed in Oregon and design must be approved by the City.
- Must be located offline of any natural drainage system.
- No groundwater flows can limit basin effectiveness. If groundwater flows are anticipated, the basin must be sized accordingly.
- Stabilized inlet, outlet, and side slope structures capable of withstanding predicted flows before the basin receives flows.
- Outlet devices must be sized to empty the basin within 48 hours. Release rates of sediment-free runoff are required to meet the post-construction flow control thresholds required in SWMM **section 1.2.5**. In soils with low infiltration rates, the basin may only provide storage and a secondary measure may be required to filter sediment and ensure that the basin maintains adequate capacity to store site runoff before any anticipated storm.
- Basin design must consider drain valves, forebays, and other features that ensure ease of maintenance.
- Adequate access must be provided for maintenance procedures.

### **Maintenance:**

- All basins must be maintained prior to major rainstorm to ensure they have capacity for flows.
- Consider type of maintenance vehicle required and provide sufficient access.
- Sediment must be removed when one-third of the basin's capacity is filled. Removed sediment must be disposed of properly.
- If a temporary sediment basin is to be used for post-construction stormwater management, all sediment must be removed prior to placement of stormwater soil and installation of plantings.

Conversion shall not take place prior to at least 90% of development being completed and permanently stabilized.

- If the developer can make a case that other upstream erosion control measures will prevent sediment from entering the basin, the City may approve conversion of the temporary sedimentation basin to permanent post-construction stormwater facility prior to construction being finished. If approved, the City will inspect facility when construction phase is complete and the developer will be responsible for sediment removal, growing media replacement and/or vegetation replacement.

## DEWATERING AND PONDED WATER MANAGEMENT – EPSC-19



### Objective:

Dewatering operations prevent or reduce the discharge of pollutants to the storm drain system or to watercourses by using sediment controls and by testing the discharges for pollution. Dewatering and ponded water management applies to areas where stormwater has collected in low spots, trenches or other depressions and needs to be removed to proceed with construction activities or for vector control.

### Installation:

- Ponded stormwater shall be settled or filtered for sediment removal prior to discharge.
- Water shall be clean and free of significant sediment, surfactants, or other pollutants.
- For clean ponded stormwater, use one of the following methods for discharge disposal as appropriate for onsite drainage:
  - Reduce sediment discharge by pumping water from the top of ponded areas using a floating or raised hose.
  - Infiltrate to an appropriate stabilized surface area (landscaped or vegetated).
  - Discharge to an on-site temporary sediment basin.
  - Only with approval by the City, discharge to a nearby waterbody or the storm drain system. Discharge flow rates must meet flow control requirements in SWMM **section 1.2.5**.
  - A vacuum truck may be used to remove the water and dispose at an authorized discharge location.

### Maintenance:

- Inspect pumps, hoses and all equipment before use. Monitor dewatering operations to ensure it does not cause offsite discharge or erosion.
- Inspect routinely, when applicable activities are under way.

## SOIL STOCKPILE MANAGEMENT – EPSC-20



### **Objective:**

Soil stockpile management reduces or eliminates stormwater and air pollution from temporary stockpiles of soil, which are susceptible because slopes may be steep and soil may be recently disturbed.

### **Installation:**

- Locate temporary stockpiles at least 50 feet away from inlets, drainage courses, or water bodies.
- Limit soil stockpile height to 15 feet, unless City approves taller stockpile.
- Perimeter sediment control (e.g., berm, sediment fence, fiber rolls, or gravel bags) at the toe of slope shall be installed at soil stockpiles year round.
- Maintain cover on stockpile using mulch or plastic sheeting whenever stockpile is not in use for more than the following periods:
  - During the wet season (October 1 - April 30): within 7 days
  - During the dry season (May 1 - Sept. 30): within 30 days
- Protect storm drain inlets, drainage courses, and receiving waters from soil stockpile erosion, using drain inlet protection and perimeter sediment controls, as appropriate.
- Implement dust control practices, as appropriate, to prevent wind erosion of stockpiled soil material.

### **Maintenance:**

- Inspect stockpiles regularly, and prior to and after storm events.
- Add mulch as needed to maintain complete cover.
- Repair rills and gullies of vegetated stockpiles.
- Check plastic anchoring system and repair or add anchors, as needed.
- Replace torn plastic sheeting and repair open seams.
- Completely remove plastic sheeting after it is no longer needed.

## CONCRETE MANAGEMENT – EPSC-21



### **Objective:**

Concrete management prevents or reduces discharge of pollutants to stormwater from concrete waste.

### **Installation:**

- Perform washout of concrete trucks off-site or in designated concrete washout areas only.
- Do not wash out concrete trucks into storm drains, streets, open ditches or streams.
- Concrete washout areas may be prefabricated concrete washout containers, or self-installed structures.
- Locate washout areas 50 feet from sensitive areas such as storm drains, open ditches, or water bodies.
- On large sites with extensive concrete work, washouts should be placed in multiple locations for ease of use by concrete equipment operators.

### **Maintenance:**

- During periods of concrete work, inspect washouts for overall condition and performance.
- Washout facilities must be emptied when washout is 75% full to prevent overflow.
- Hardened concrete, slurries and liquids from washout must be disposed of properly.
- Holes, depressions or other ground disturbance caused by the removal of temporary concrete washout facilities shall be backfilled, repaired, and stabilized to prevent erosion.

## MATERIALS MANAGEMENT – EPSC-22



### **Objective:**

Prevent, reduce, or eliminate the discharge of pollutants to the stormwater system or watercourses from material delivery and storage. Minimize the storage of hazardous materials on-site, store materials in a designated area, and install secondary containment.

### **Installation:**

- All construction materials shall be delivered to and stored in designated areas or designated staging areas at the construction site.
- Material storage areas shall be placed near construction site entrances to the extent practicable, away from storm drain inlets, culverts and surface waterbodies.
- Designated storage areas shall be kept clean, well-organized, and litter-free.
- Any materials being stored that could release pollutants by wind or runoff transport shall be protected by overhead cover, secondary containment, tarpaulins, or other appropriate method prior to rainfall or periods of high wind. Where feasible, store materials indoors (e.g., container storage or garages/buildings under construction, where work is being conducted).
- Any chemicals, drums or bagged materials not stored in a covered location, shall be stored on pallets and in secondary containment.
- Secondary containment shall be provided for liquids.
- Secondary containment areas shall be covered to prevent accumulation of rainwater.
- Construction materials shall be stored in a manner to prevent or minimize contact with storm water.

### **Maintenance:**

- Inspect material storage areas routinely for compliance with the above practices.

## SANITARY WASTE MANAGEMENT – ESPC-23



### **Objective:**

Sanitary and septic waste management controls minimize or eliminate the discharge of construction site sanitary/septic waste materials to the storm drain system or to watercourses.

### **Installation:**

- All sanitary wastes shall be collected and managed through the use of portable toilet facilities.
- Portable toilets shall be placed on a level surface and to the extent practical, a safe distance away from paved areas and away from storm drains.
- If placed in an area of high winds, portable toilets shall be secured to the ground to prevent blowing over.
- Portable toilets shall be transported to and from the construction site by a licensed contractor.
- No sanitary wastes shall be disposed of on-site (e.g., to on-site storm drains, burial).
- Care shall be taken during pump-out to avoid spillage. If spillage occurs, it shall be cleaned up immediately.

### **Maintenance:**

- Inspect material storage areas routinely for compliance with the above practice

## EPSC Plan for Detached Dwelling – City of Gresham

The following commitments constitute my Erosion Prevention and Sediment Control (EPSC) Plan as required under the City’s EPSC Manual. In developing this plan, I certify that I have evaluated site contours and drainage patterns, identified potential erosion and sediment problems, evaluated EPSC measures, and will implement EPSC measures prior to performing any earthwork or site grading. I will follow this plan and make ongoing revisions as needed to ensure sediment stays on site and other construction-related pollutants and debris are kept out of stormwater and other waters.

I further certify that all EPSC measures will be installed in accordance with City requirements including the City’s Stormwater Management Manual and EPSC Manual. I understand that the City will inspect my site for implementation of this EPSC Plan before and during construction, and that a stop-work order may be issued if I fail to properly implement EPSC measures.

	Responsibilities	Initial
1.	I understand I am responsible, as the permit holder, to keep sediment onsite.	
2.	I will provide a linear barrier (such as a sediment fence) and perimeter control where needed to keep sediment onsite.	
3.	I will ensure that construction debris, paint, concrete, and other pollutants are kept out of stormwater, streams, storm drains, and any stormwater treatment systems such as street raingardens.	
4.	I will provide storm drain inlet protection.	
5.	I will provide construction entrance/exit tracking controls.	
6.	I will provide concrete management.	
7.	I will provide slope breaks for steep slopes.	
8.	I will provide stockpile management for both soil stockpiles and non-soil stockpiles.	
9.	I will provide temporary ground cover (such as straw mulch) during October 1 – May 31, or until wet weather subsides, and permanent seeding and planting.	
10.	I will provide daily inspection and maintenance when work is ongoing, as needed during wet weather, and even if work is not ongoing to ensure this plan is met.	
11.	I will remove temporary erosion controls once construction is completed and the site is stabilized.	
12.	I understand the City may require modifications or additional EPSC measures to be installed onsite.	

Name: \_\_\_\_\_ Phone Number: \_\_\_\_\_

Full Construction Property Address: \_\_\_\_\_

Person Responsible for Implementing and Inspecting EPSC Measures: \_\_\_\_\_

Phone Number: \_\_\_\_\_

## Erosion Prevention and Sediment Control Standard Details

**Table C-2.** Erosion control standard details

<b>Standard Detail</b>	<b>BMP Name</b>	<b>BMP Fact Sheet Page</b>	<b>Standard Detail Page</b>
EPSC-1	Scheduling	C-9	-
EPSC-2	Preservation of Existing Vegetation/Buffer Strips	C-10	C-35
EPSC-3	Construction Entrance/Exit Tracking Controls	C-11	C-36
EPSC-4	Sediment Fence	C-12	C-37
EPSC-5	Fiber Rolls/Wattles	C-13	C-38
EPSC-6	Compost Berm/Sock	C-14	C-39
EPSC-7	Undercut Lots/Sidewalk Subgrades	C-15	C-40
EPSC-8A	Catch Basin Inlet Protection	C-16	C-41
EPSC-8B	Inlet Protection		C-42
EPSC-9	Surface Roughening	C-17	C-43
EPSC-10	Hydroseeding, Mulching and Tackifiers	C-18	C-44
EPSC-11	Erosion Blankets and Mats	C-19	C-45
EPSC-12	Seeding and Planting (Temporary and Permanent)	C-20	-
EPSC-13	Wind Erosion/Dust Control	C-21	-
EPSC-14	Slope Drain	C-22	C-46
EPSC-15	Energy Dissipation/Outlet Protection	C-23	C-47
EPSC-16	Diversion Dikes/Swales	C-24	C-48
EPSC-17A	Rock Check Dam	C-25	C-49
EPSC-17B	Wattle Check Dam		C-50
EPSC-17C	Sand bag Check Dam		C-51
EPSC-18	Temporary Sediment Basin	C-26	C-52
EPSC-19	Dewatering and Poned Water Management	C-28	-
EPSC-20	Soil Stockpile Management	C-29	C-53
EPSC-21	Concrete Management	C-30	C-54
EPSC-22	Materials Management	C-31	-
EPSC-23	Sanitary Waste Management	C-32	-

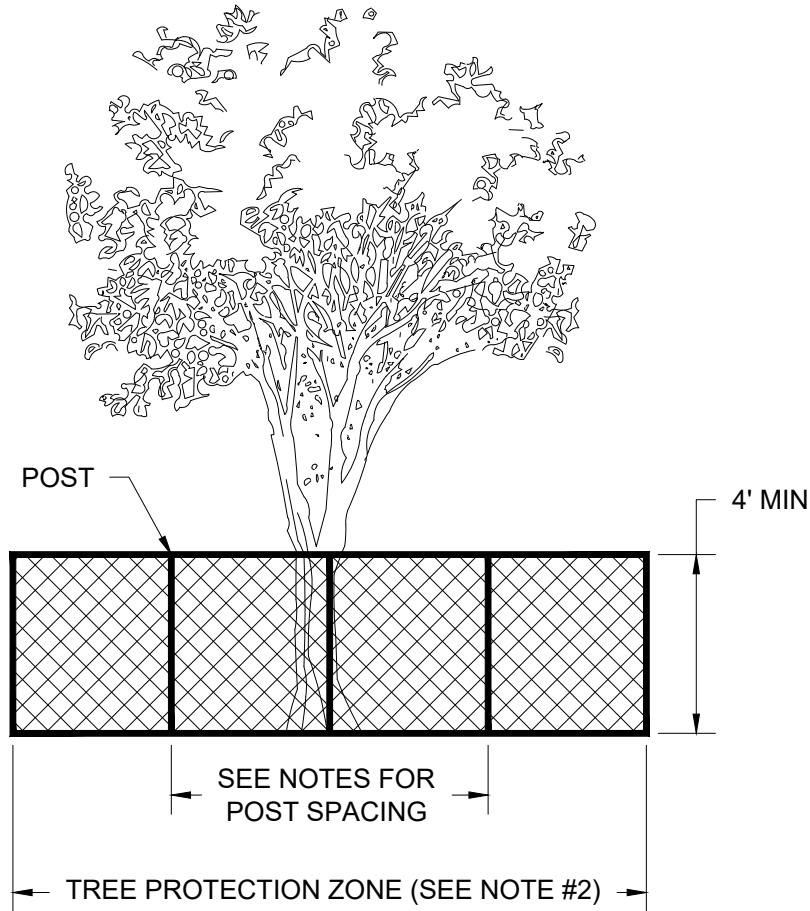

**NOTES:**

1. LIMITS FOR PRESERVATION OF EXISTING TREES OR VEGETATION SHALL BE MARKED PRIOR TO ALL CLEARING, GRUBBING OR SOIL DISTURBANCE ACTIVITIES.
2. MINIMUM TREE PROTECTION ZONE IS THE LARGER OF THE FOLLOWING:
  - A. 15' RADIUS FROM THE EDGE OF THE TREE TRUNK
  - B. DRIPLINE
  - C. 1' FOR EACH INCH OF TREE DIAMETER AT BREAST HEIGHT (4.5' OFF GROUND)
3. FOR TREE PROTECTION, USE CHAIN LINK FENCE. POSTS SHALL BE A MAXIMUM OF 10' SPACING, DRIVEN 2' MINIMUM INTO GROUND. SURFACE MOUNTED POLE SUPPORTS MAY BE USED IF APPROVED BY THE CITY.
4. FOR PROTECTION OF PERIMETER VEGETATION, AN ORANGE POLY FENCE WITH MAXIMUM OPENINGS OF 2" X 2" MAY BE USED AS AN ALTERNATE. POSTS SHALL BE A MAXIMUM OF 4' SPACING WHEN POLY FENCE IS USED.
5. PROTECTIVE AREA OF TREES TO BE PRESERVED SHALL BE BEYOND CRITICAL ROOT ZONE FOR TREATMENT OF SHEET FLOW.
6. LIMIT TRENCHING NEAR OR UNDER TREES TO BE PRESERVED FOR TREATMENT OF SHEET FLOW.
7. SMOOTHLY CUT OFF ENDS OF ANY DAMAGED ROOTS AND COVER WITH SOIL.

NTS

**CITY OF  
GRESHAM**

**PROTECTION OF TREES AND VEGETATION**

PUBLISHED: JULY 2026

DRAWN	KRB
REV. DATE	NOV 2022
APPR.	
DETAIL NO.	EPSC-2

FILENAME: y:\inter-departmental\development\engineering\projects\public works standards\2.0 pws revision copy\details\cad -all\st and epsc details\epsc cad details\epsc-3.dwg, Plotted 6/22/2026 3:05 PM, By: Anthony Dolowich, ANSI FULL BLEED A (8.50 X 11.00 INCHES)

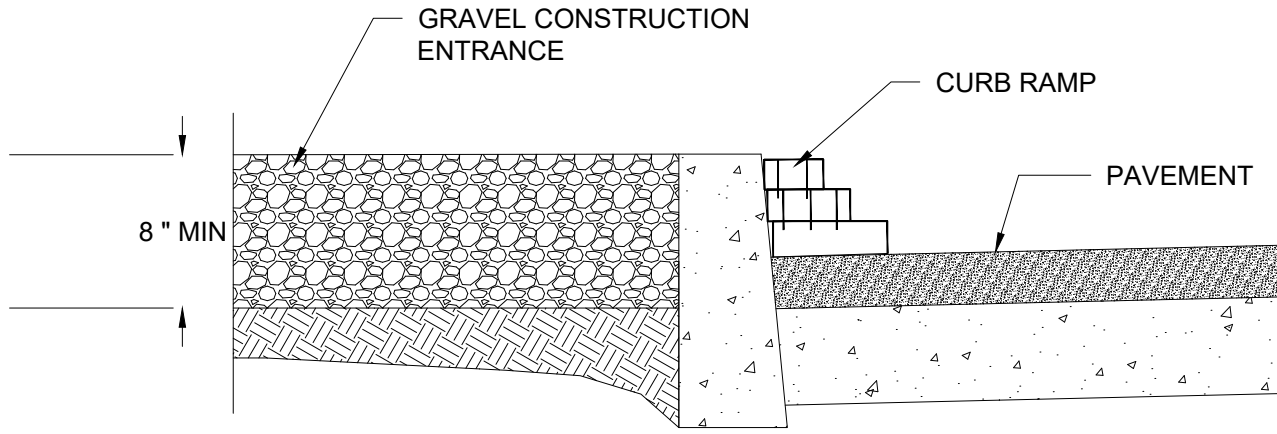
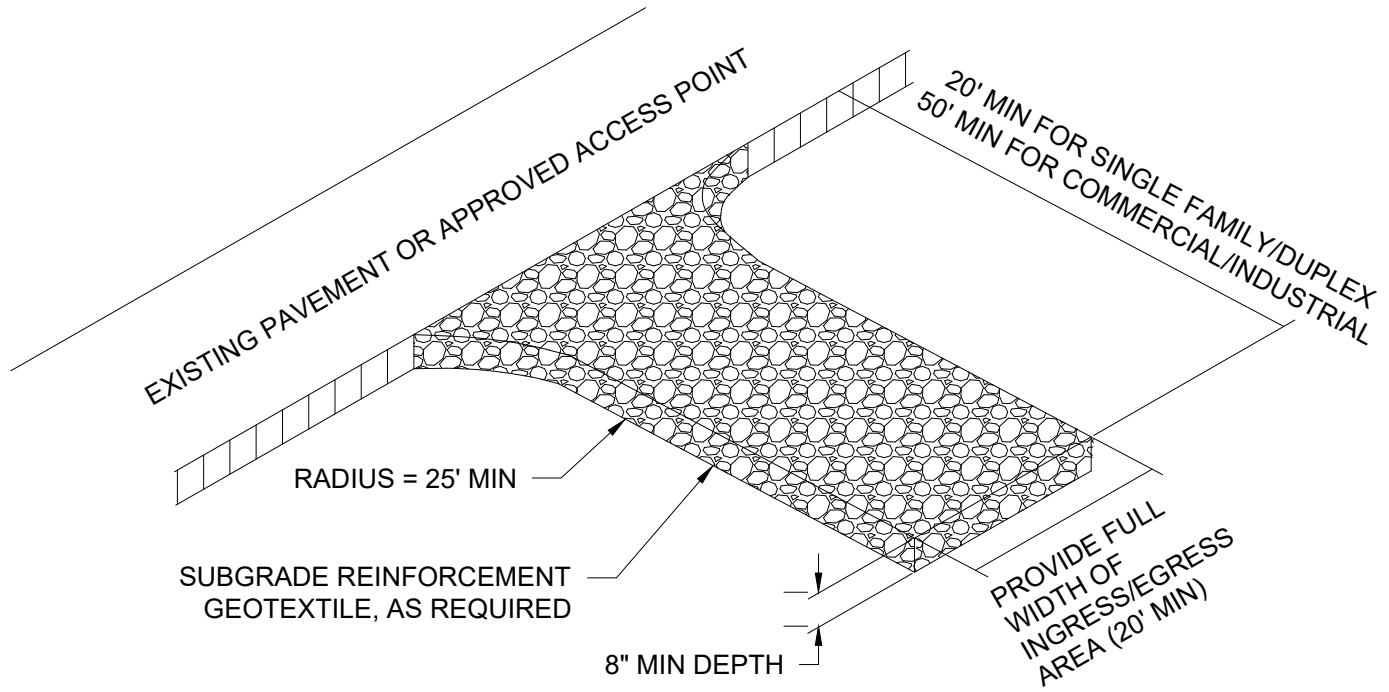

**NOTES:**

1. DO NOT INSTALL ROCK ON PAVED SURFACES (USE WOOD CURB RAMPS)
2. INCLUDE A TIRE WASH FACILITY IF THE ENTRANCE DOES NOT PROVE EFFECTIVE IN RETAINING SEDIMENT ONSITE
3. SWEEP/REMOVE ANY SEDIMENT TRACKED OFFSITE
4. ADD/REPLACE ROCK AS NEEDED TO ENSURE SPECIFIED DIMENSIONS AND IF NO LONGER TRAPPING SEDIMENT

**DIMENSIONS:**

SINGLE FAMILY  
20' LONG BY 20' MIN WIDTH  
8" DEEP OF 3/4" MINUS ROCK

COMMERCIAL  
50' LONG BY 20' MIN WIDTH  
8" DEEP OF 3"-6" CLEAN ROCK.  
GEOTEXTILE FABRIC MAY BE REQUIRED IF SUB-SOIL PUMPING OCCURS

NTS

**CITY OF GRESHAM**

**CONSTRUCTION ENTRANCE/EXIT TRACKING CONTROLS**

PUBLISHED: JULY 2026

DRAWN	KJR
REV. DATE	SEPT 2014
APPR.	
DETAIL NO.	EPSC-3

FILENAME: y:\inter-departmental\development engineering projects\public works standards\2.0 pws revision copy\details\cad -all\st and epsc details\epsc cad details\epsc-4.dwg, Plotted 6/22/2026 3:05 PM, By: Anthony Dollowitch, ANSI FULL BLEED A (8.50 X 11.00 INCHES)

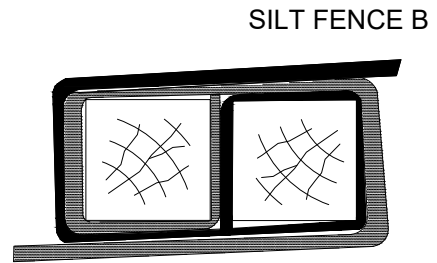
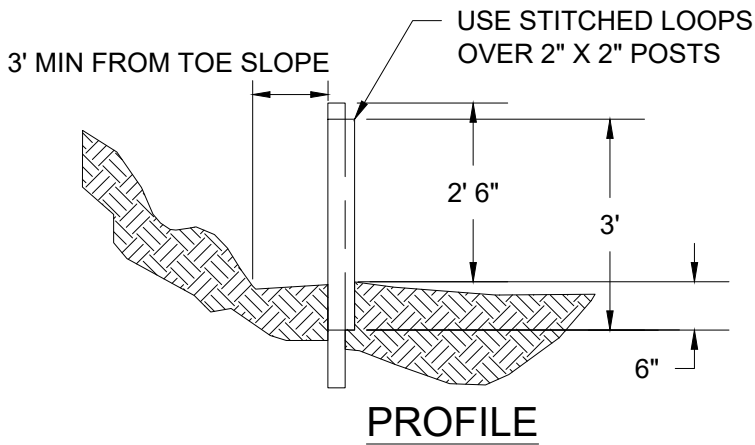

**ROLL JOINTS**

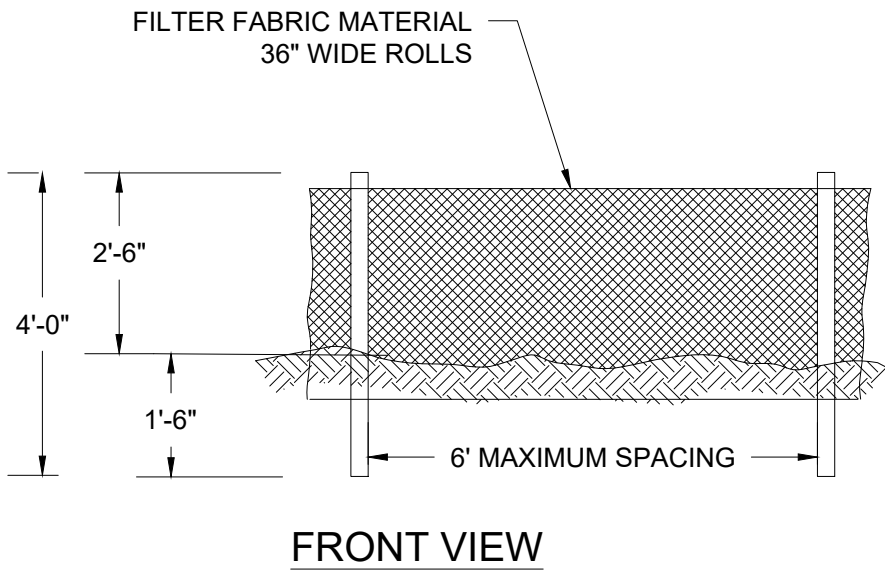

**SPACING REQUIREMENTS:**

PERCENT SLOPE	SLOPE	MAX SPACING
<20	LESS THAN 5H:1V	100'
20 TO 30	5H:1V TO 3H:1V	50'
>30	GREATER THAN 3H:1V	25'

**NOTES:**

1. PLACE ALONG CONTOUR OF SLOPE OR AT PERIMETER OF SITE.
2. DO NOT PLACE IN STREAM CHANNELS OR CONCENTRATED FLOWS
3. BURY BOTTOM OF FILTER FABRIC 6" VERTICALLY BELOW FINISHED GRADE
4. 2"X2" FIR, PINE OR STEEL FENCE POSTS
5. POSTS TO BE INSTALLED ON UPHILL SIDE OF SLOPE
6. COMPACT BOTH SIDES OF FILTER FABRIC
7. ANGLE SILT FENCE AT END OF CONTOUR FOR ONE FULL 6' PANEL TO ASSURE SOIL IS TRAPPED

NTS

**CITY OF GRESHAM**

**SILT FENCE**

PUBLISHED: JULY 2026

DRAWN	KJR
REV. DATE	SEPT 2014
APPR.	
DETAIL NO.	EPSC-4

FILENAME: y:\inter-departmental\development\engineering\projects\public works standards\2.0 pws revision copy\details\cad -all\st and epsc details\epsc cad details\epsc-5.dwg, Plotted 6/22/2026 3:05 PM, By: Anthony Dolowitch, ANSI FULL BLEED A (8.50 X 11.00 INCHES)

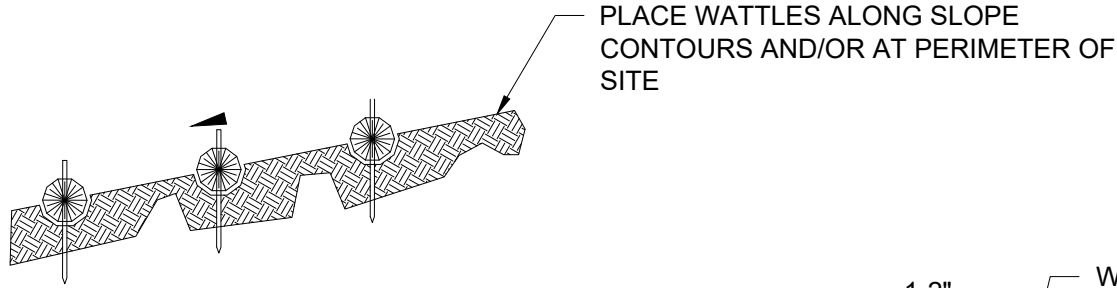

**PROFILE**

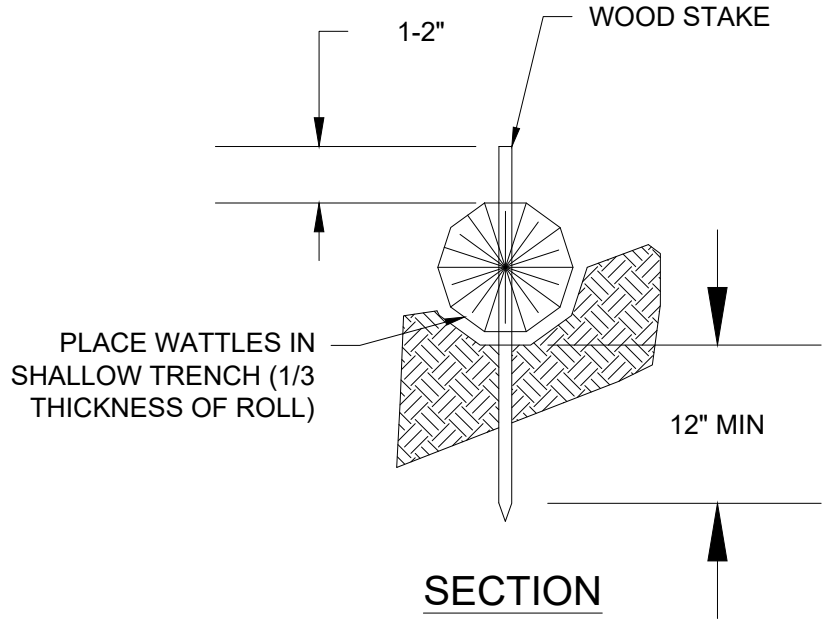

**SECTION**

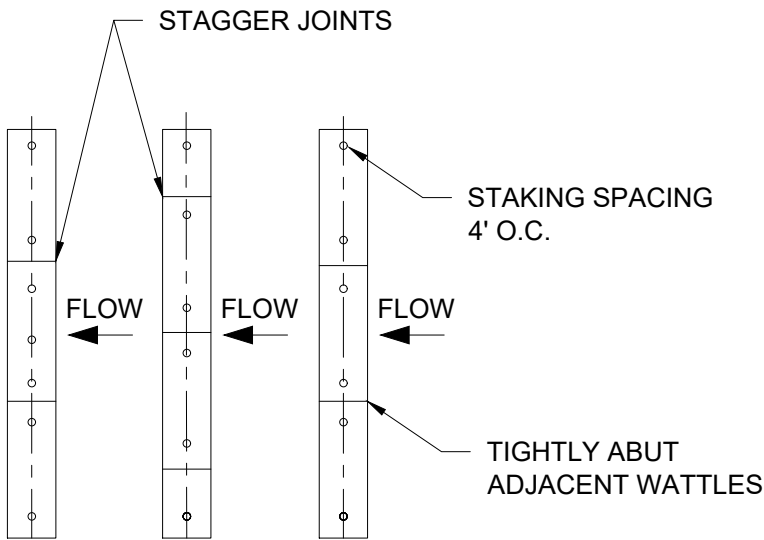

**PLAN VIEW**

**NOTES:**

1. STAKING SPECIFICATIONS:
  - a.  $\frac{3}{4}$ " x  $\frac{3}{4}$ " WOODEN STAKES
  - b. ADDITIONAL STAKES MAY BE INSTALLED ON DOWNHILL SIDE OF WATTLES, ON STEEP SLOPE OR HIGHLY EROSION SOILS
  - c. STAKES SHOULD BE DRIVEN 12" MIN INTO GROUND
2. SEE TABLE FOR SPACING ON SLOPES

**SLOPING REQUIREMENTS:**

PERCENT SLOPE	SLOPE	MAX SPACING
<20	LESS THAN 5H:1V	100'
20 TO 30	5H:1V TO 3H:1V	50'
>30	GREATER THAN 3H:1V	25'

NTS

**CITY OF GRESHAM**

**FIBER ROLLS/WATTLES**

PUBLISHED: JULY 2026

DRAWN	KJR
REV. DATE	SEPT 2014
APPR.	
DETAIL NO.	EPSC-5

FILENAME: y:\inter-departmental\development\engineering\projects\public works standards\2.0 pws revision copy\details\cad -all\st and epsc details\epsc cad details\epsc-6.dwg, Plotted 6/22/2026 3:05 PM, By: Anthony Dolowitch, ANSI FULL BLEED A (8.50 X 11.00 INCHES)

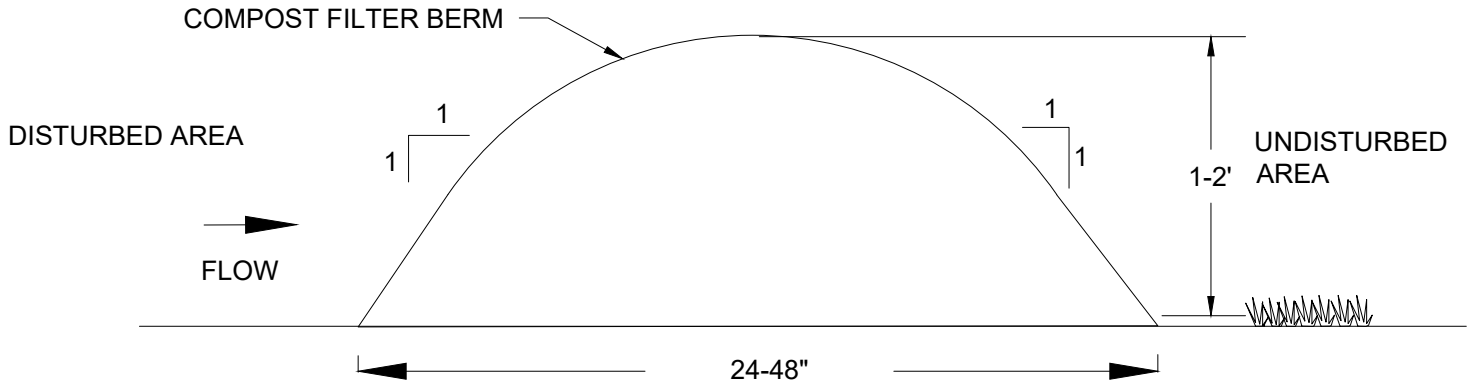

**COMPOST BERM SECTION VIEW**

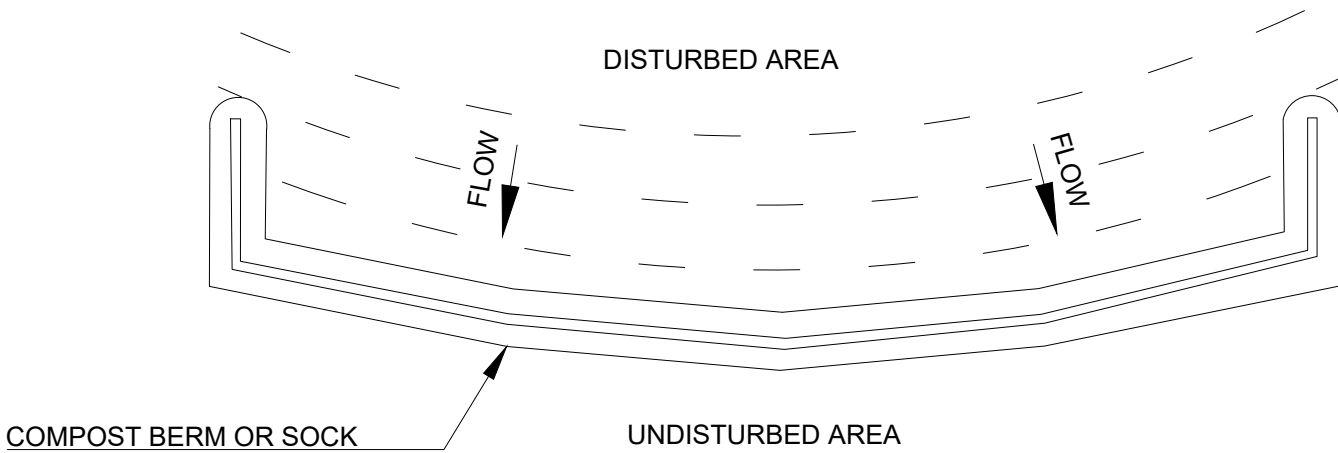

**PLAN VIEW**

**NOTES:**

1. COMPOST NEEDS TO BE STABLE AND MATURE SEDIMENT SHALL BE REMOVED WHEN IT REACHES  $\frac{1}{3}$  OF THE EXPOSED HEIGHT OF SOCK OR BERM
2. PLACE BERMS OR SOCK ON CONTOUR AND/OR AT PERIMETER OF SITE.
3. PLACE 5' OR MORE FROM TOE OF SLOPE TO MAXIMIZE SPACE FOR SEDIMENT DEPOSITION
4. DO NOT PLACE ACROSS STREAMS, CHANNELS OR CONCENTRATED FLOW

**SPACING REQUIREMENTS:**

SLOPE	HEIGHT	BASE WIDTH	MAX SPACING
<5H:1V	12" MIN	24" MIN	100'
5H:1V TO 3H:1V	24" MIN	48" MIN	50'
≥3H:1V	≥24"	≥48"	25'

NTS

**CITY OF GRESHAM**

**COMPOST BERM/SOCK**

PUBLISHED: JULY 2026

DRAWN	KRJ
REV. DATE	SEPT 2014
APPR.	
DETAIL NO.	EPSC-6

FILENAME: y:\inter-departmental\development\engineering\projects\public works standards\2.0 pws revision copy\details\cad -all\st and epsc details\epsc cad details\epsc-7.dwg, Plotted 6/22/2026 3:05 PM, By: Anthony Dollowitch, ANSI FULL BLEED A (8.50 X 11.00 INCHES)

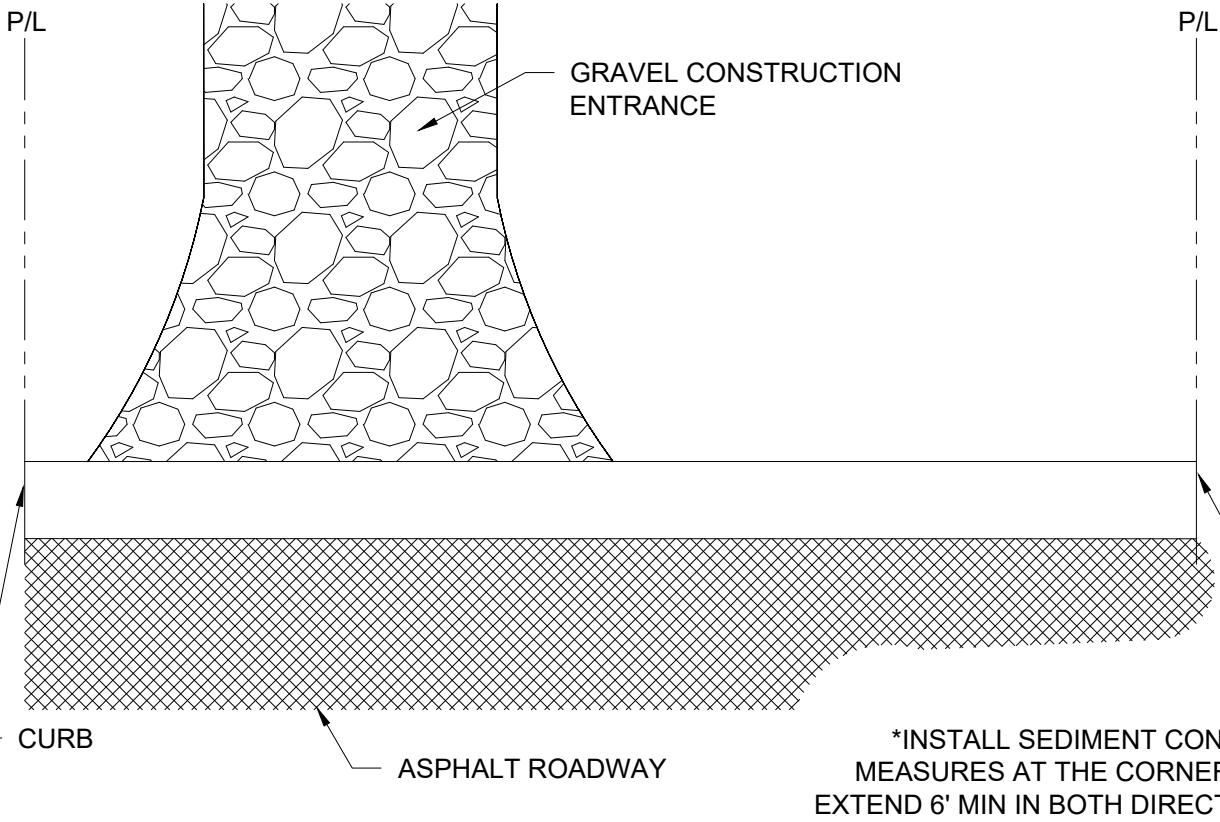

**PLAN VIEW**

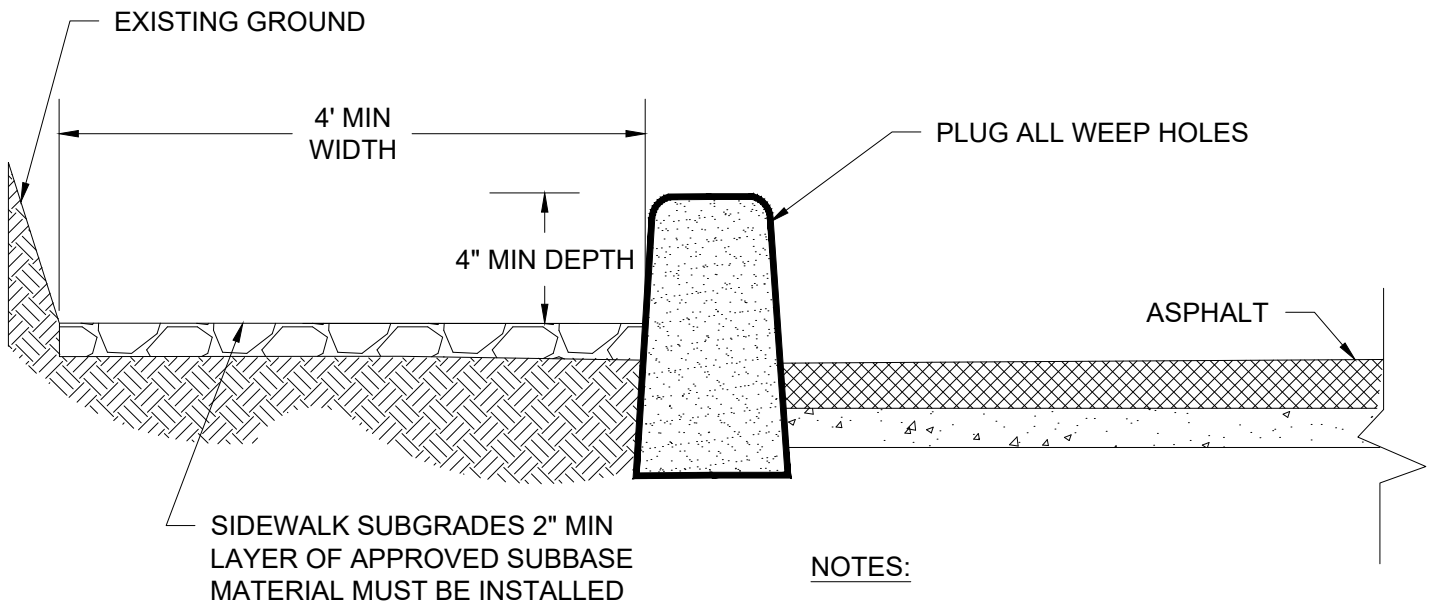

**PROFILE**

**NOTES:**

1. NOT APPLICABLE FOR SITES WITH SLOPE
2. CUT SOIL BACK FROM CURB 2-4" DEEP AND 4' WIDE
3. INSTALL 2" MIN AGGREGATE SUBGRADE
4. REMOVE AND REPLACE AGGREGATE IF 50% IS CLOGGED WITH SEDIMENT

NTS

**CITY OF GRESHAM**

**UNDERCUT LOTS/SIDEWALK SUBGRADE**

PUBLISHED: JULY 2026

DRAWN	KJR
REV. DATE	SEPT 2014
APPR.	
DETAIL NO.	EPSC-7

FILENAME: \\inter-departmental\development\engineering\projects\public works standards\2.0 pws revision copy\details\cad -all\st and epsc details\epsc cad details\epsc-8a.dwg, Plotted 6/22/2026 3:05 PM, By: Anthony Dollowitch, ANSI FULL BLEED A (6.50 X 11.00 INCHES)

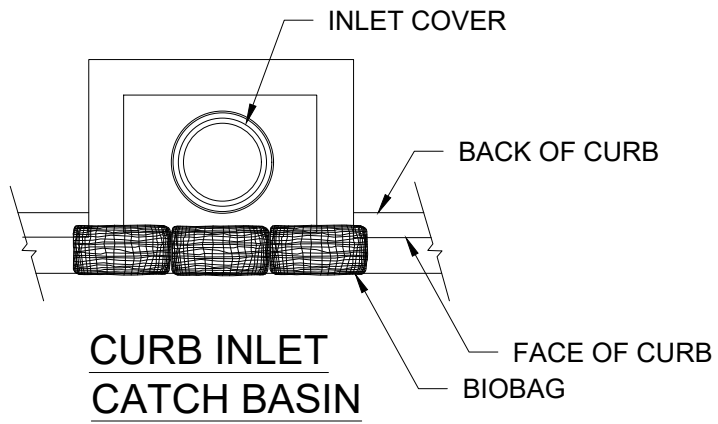

- NOTES:**
1. TO BE INSTALLED IN ALL CATCH BASINS IMMEDIATELY DOWNSLOPE FROM SITE
  2. INSTALL PER MANUFACTURER SPECIFICATIONS
  3. STORM DRAINS WITH RECESSED CURB INLETS SHALL USE FOAM BLOCK OR BIOBAG TO DIRECT STORMWATER INTO INSERT BAG
  4. REPLACE OR CLEAN WHEN BAG IS 1/3 FULL

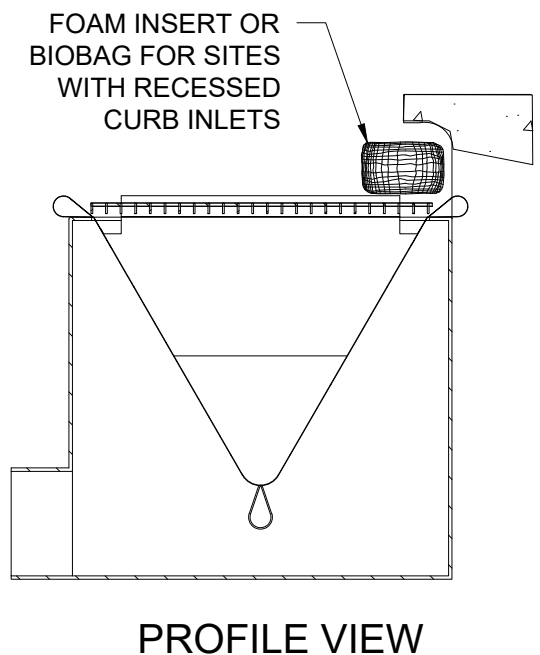
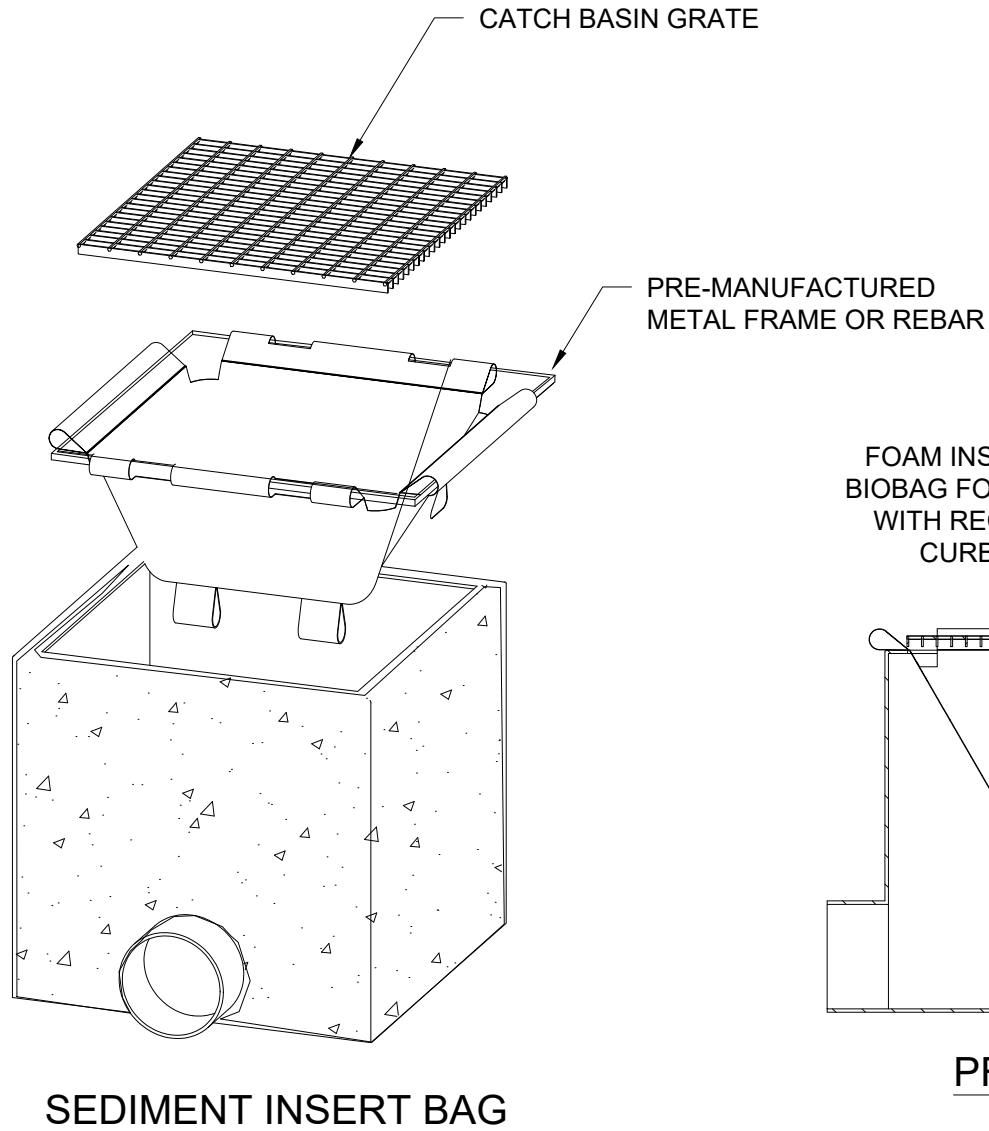

**CITY OF GRESHAM**

**CATCH BASIN INLET PROTECTION**

PUBLISHED: JULY 2026

DRAWN	KJR
REV. DATE	SEPT 2014
APPR.	
DETAIL NO.	EPSC-8A

FILENAME: y:\inter-departmental\development\engineering projects\public works standards\2.0 pws revision copy\details\cad -all\st and epsc details\epsc cad details\epsc-8b.dwg, Plotted 6/22/2026 3:05 PM, By: Anthony Dolowitch, ANSI FULL BLEED A (8.50 X 11.00 INCHES)

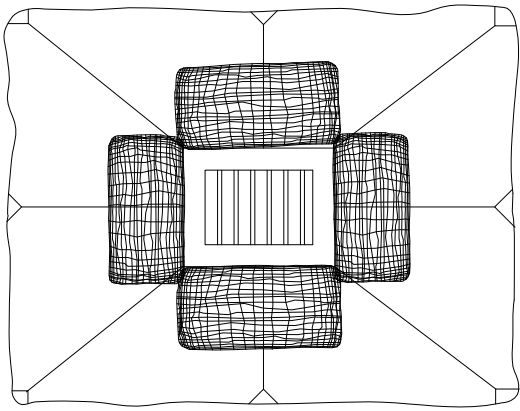

AREA DRAIN PLAN VIEW

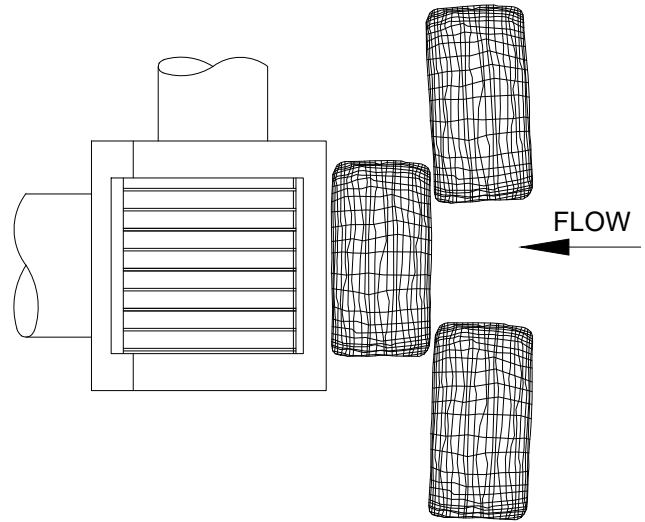

DITCH INLET PLAN VIEW

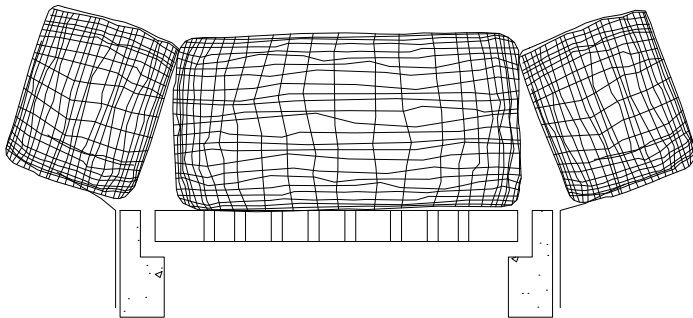

AREA DRAIN PROFILE VIEW

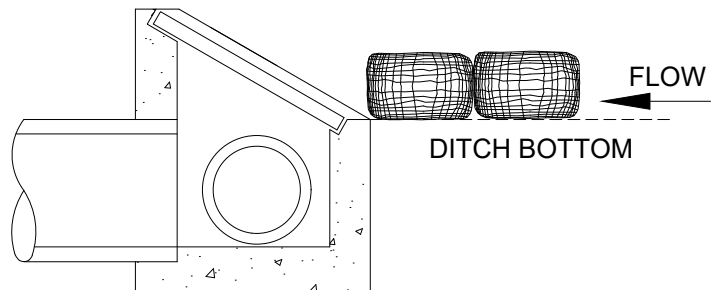

DITCH INLET PROFILE

NOTES:

1. ONLY TO BE USED IN UNPAVED AREAS WITHOUT TRAFFIC
2. BARRIER SHALL FULLY COVER INLETS
3. BIOFILTER BAGS SHOULD BE STAKED WHERE APPLICABLE USING (2) 1"X2" WOODEN STAKES OR APPROVED EQUAL PER BAG
4. CLEAN/REPLACE BAGS WHEN CAPACITY REDUCED BY 50% OR WHEN SEDIMENT IS 1/3 HEIGHT OF BIOBAG

**CITY OF GRESHAM**

**INLET PROTECTION**

PUBLISHED: JULY 2026

DRAWN	KJR
REV. DATE	SEPT 2014
APPR.	
DETAIL NO.	EPSC-8B

FILENAME: y:\inter-departmental\development\engineering\projects\public works standards\2.0 pws revision copy\details\cad - all\st and epsc details\epsc cad details\epsc-9.dwg, Plotted 6/22/2026 3:05 PM, By: Anthony Dollowitch, ANSI FULL BLEED A (8.50 X 11.00 INCHES)

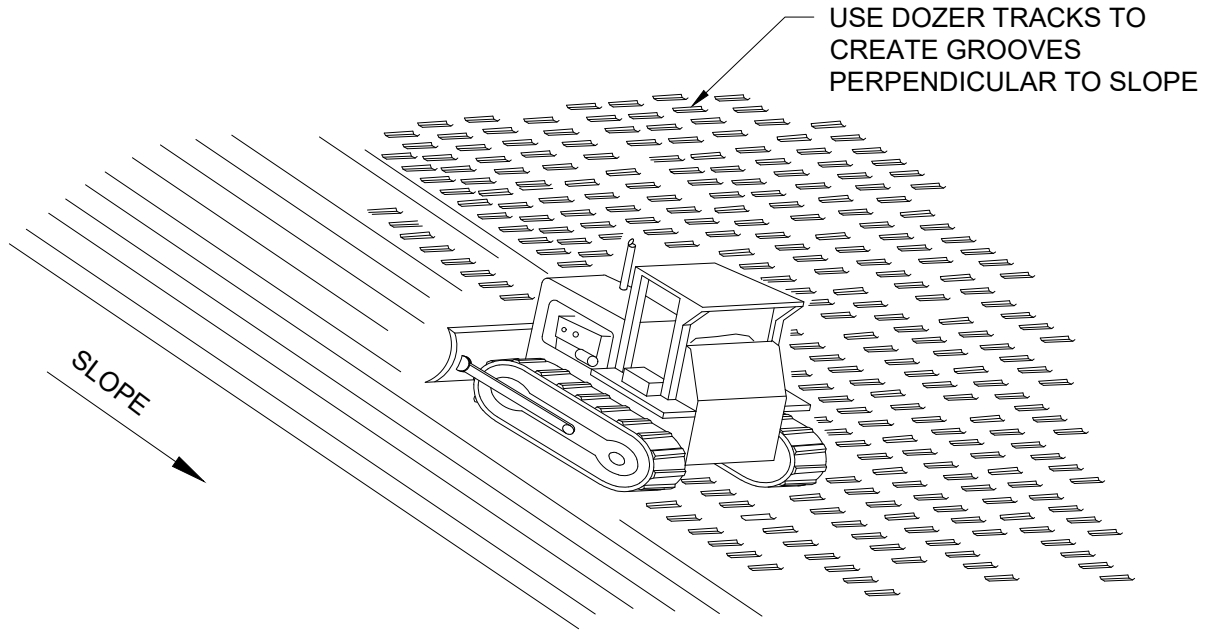

**NOTES:**

1. USE SHEEPSFOOT ROLLER OR MACHINERY
2. GROOVES SHOULD BE CLOSE TOGETHER ( $\leq 10''$ ) AND NOT LESS THAN 1" DEEP
3. SEED AND MULCH ROUGHENED AREAS AS SOON AS POSSIBLE

**TRACKING**

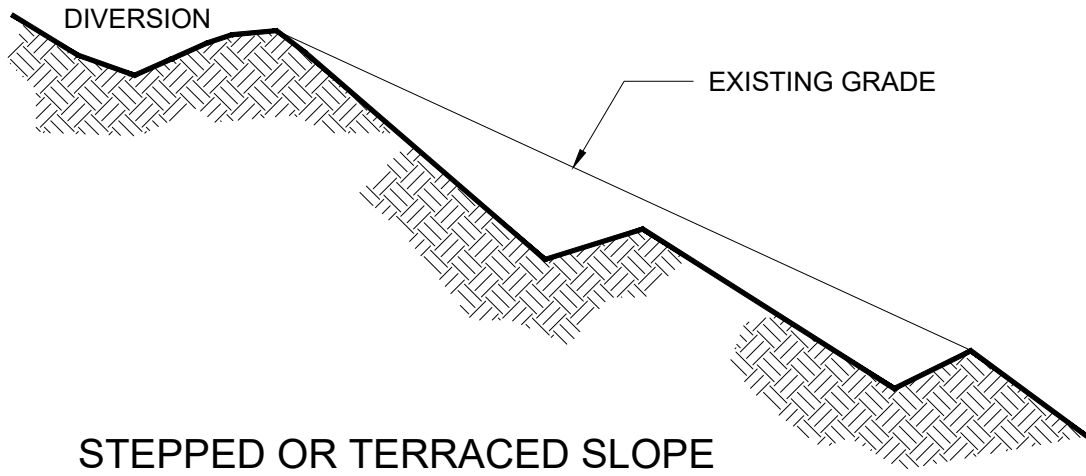

**STEPPED OR TERRACED SLOPE**

**NOTES:**

1. FOR USE ON SLOPES STEEPER THAN 3H:1V
2. VERTICAL CUT DISTANCE SHALL BE LESS THAN HORIZONTAL DISTANCE
3. VERTICAL CUT SHALL NOT EXCEED 2 FT. (0.6m) IN SOFT MATERIAL AND 3 FT. (0.9m) IN ROCKY MATERIAL
4. RIDGES/DEPRESSIONS SHOULD RUN PARALLEL TO SLOPE CONTOURS

**CITY OF GRESHAM**

**SURFACE ROUGHENING**

PUBLISHED: JULY 2026

DRAWN KJR

REV. DATE SEPT 2014

APPR. 

DETAIL NO. EPSC-9

**COMPOST BERM OR OTHER PERIMETER CONTROL (TYP)**

NOTES:

1. REMOVE DEBRIS FROM SLOPE AND SCARIFY
2. TRACKWALK THE SLOPE IF NECESSARY
3. APPLY HYDROSEED, MULCH, OR COMPOST AT SPECIFIED RATE; EXTEND BLANKET AT LEAST 3' BEYOND TOP OF SLOPE
4. ADD PERIMETER CONTROL AT TOP AND/OR BOTTOM OF SLOPE

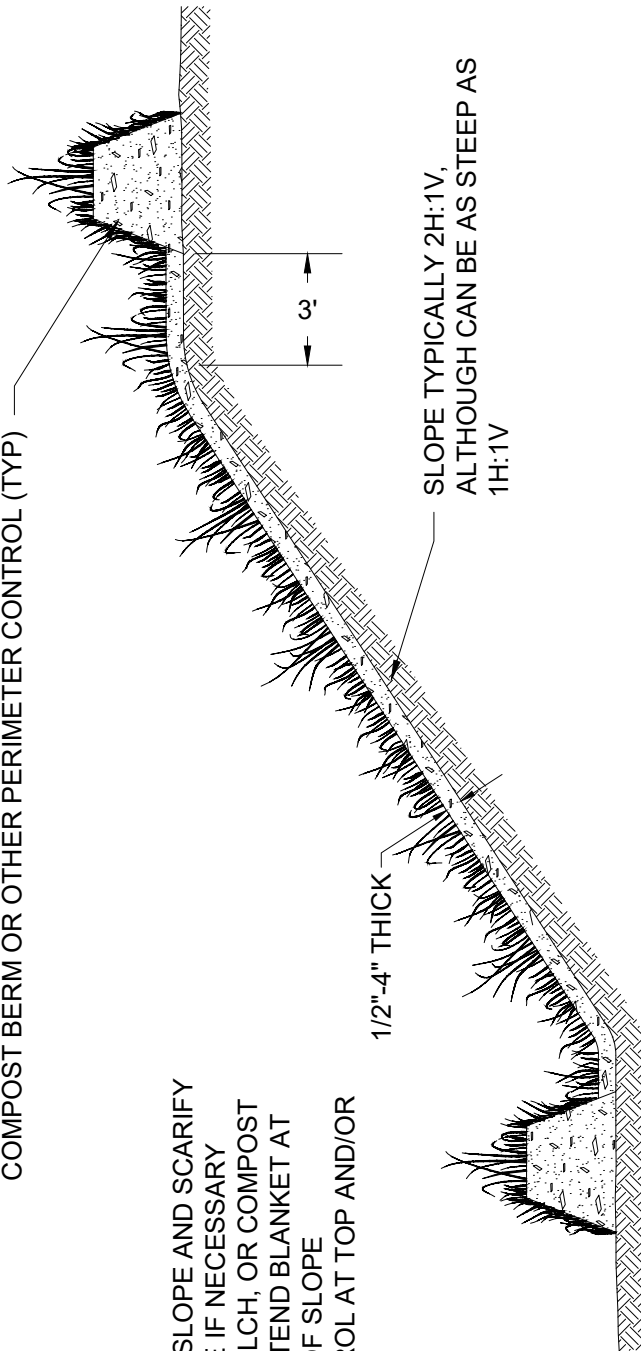

**MULCH MATERIAL TABLE:**

MULCH MATERIAL	APPLICATION RATE	DEPTH	NOTES
STRAW	2-3 TONS/ACRE	2-3 INCHES	ONLY FOR SHORT TERM USE (<3 MONTHS); DEPTH MAY BE REDUCED BY HALF IF USED WITH SEED
WOOD FIBER CELLULOSE	1000-1500 LBS/ACRE	N/A	APPLY WITH HYDROMULCHER; REQUIRES USE OF TACKIFIER AND SEED
BONDED FIBER MATRIX (BFM)	3000-4000 LBS/ACRE	N/A	APPLY WITH HYDROMULCHER; REQUIRES USE OF TACKIFIER AND SEED
COMPOST	3-6 TONS/ACRE	2" FOR SLOPES <3:1; 3" FOR SLOPES 2:1	EXCELLENT SOIL AMENDMENT; USE 3/4" FOR SLOPES <3:1 AND 1 1/2" FOR 2:1 SLOPES
WOOD CHIPS OR GRINDINGS	5-6 TONS/ACRE	2" MIN	NOT FOR USE ON SLOPES >10% OR WITHIN 200' OF SURFACE WATER
GRAVEL OR CRUSHED ROCK	9 YARDS/1000 SQUARE FEET	3 INCHES	SUITABLE FOR SHORT SLOPES AND AREAS OF HIGH FOOT TRAFFIC

FILENAME: y:\inter-departmental\development\engineering\projects\public\works\standards\2.0\pws\revision\copy\details\cad -all\st and epsc\details\epsc\cad\details\epsc-11.dwg, Plotted 6/22/2026 3:05 PM, By: Anthony Dollowitch, ANSI FULL BLEED A (8.50 X 11.00 INCHES)

MATS/BLANKETS SHOULD BE INSTALLED VERTICALLY DOWNSLOPE

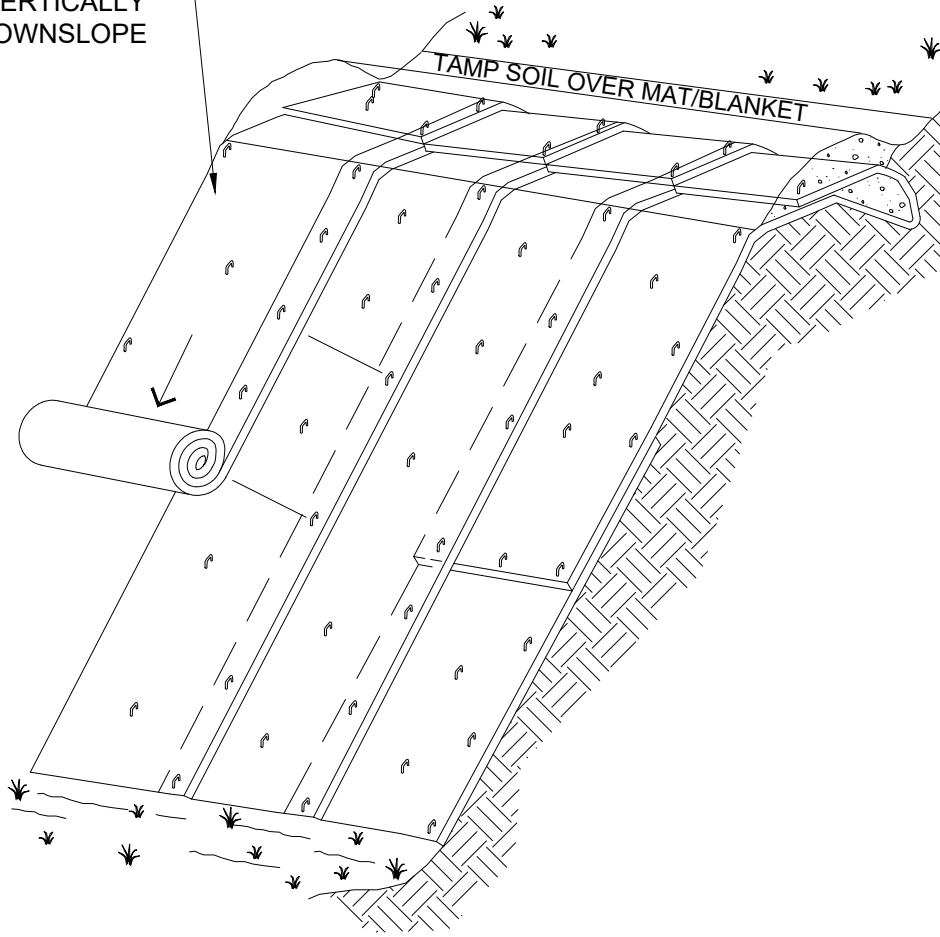

**ISOMETRIC VIEW**

**EROSION BLANKET MATERIAL:**

**NOTES:**

1. SLOPE SURFACE SHALL BE FREE OF ROCKS, CLOUDS, STICKS AND GRASS; MATS/BLANKETS SHALL HAVE GOOD SOIL CONTACT
2. APPLY PERMANENT SEEDING BEFORE PLACING BLANKETS
3. LAY BLANKETS LOOSELY AND STAKE OR STAPLE TO MAINTAIN DIRECT CONTACT WITH THE SOIL. DO NOT STRETCH
4. STAPLE ACCORDING TO MANUFACTURER SPECIFICATIONS

MATTING TYPE	SLOPE APPLICATION	CHANNEL APPLICATIONS (VELOCITIES IN FEET PER SECOND)
STRAW	3H:1V OR LESS	N/A
JUTE	3H:1V OR LESS, OR SHORT 2H:1V	N/A
CURLED WOOD FIBER (EXCELSIOR)	2H:1V OR LESS	LOW FLOW (<8 FPS)
STRAW/COCONUT	2H:1V OR LESS	N/A
COCONUT	1H:1V OR LESS	LOW FLOW (<8 FPS)
COIR FABRIC	1H:1V OR LESS	MEDIUM FLOW (8-10 FPS)
TURF REINFORCEMENT MAT (TRM)	1H:1V	HIGH FLOW (8-20 FPS)

**CITY OF GRESHAM**

**EROSION BLANKETS AND MATS**

PUBLISHED: JULY 2026

DRAWN KJR

REV. DATE SEPT 2014

APPR. 

DETAIL NO. EPSC-11

FILENAME: y:\inter-departmental\development\engineering\projects\public works standards\2.0 pws revision copy\details\cad - all\st and epsc details\epsc cad details\epsc-14.dwg, Plotted 6/22/2026 3:05 PM, By: Anthony Dollowitch, ANSI FULL BLEED A (8.50 X 11.00 INCHES)

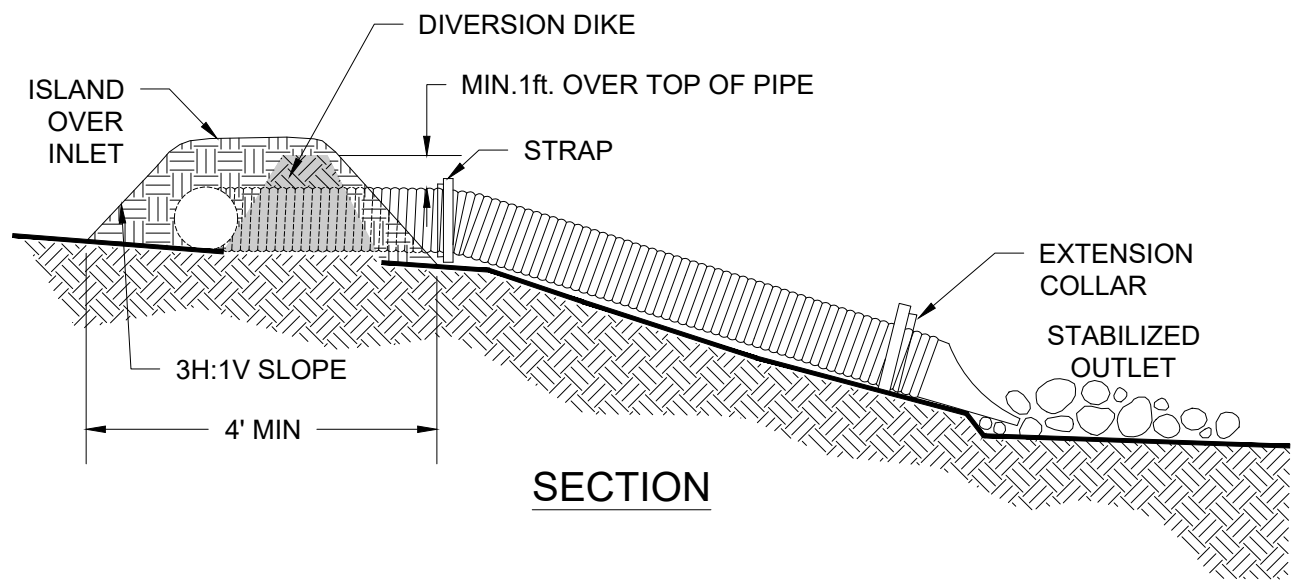
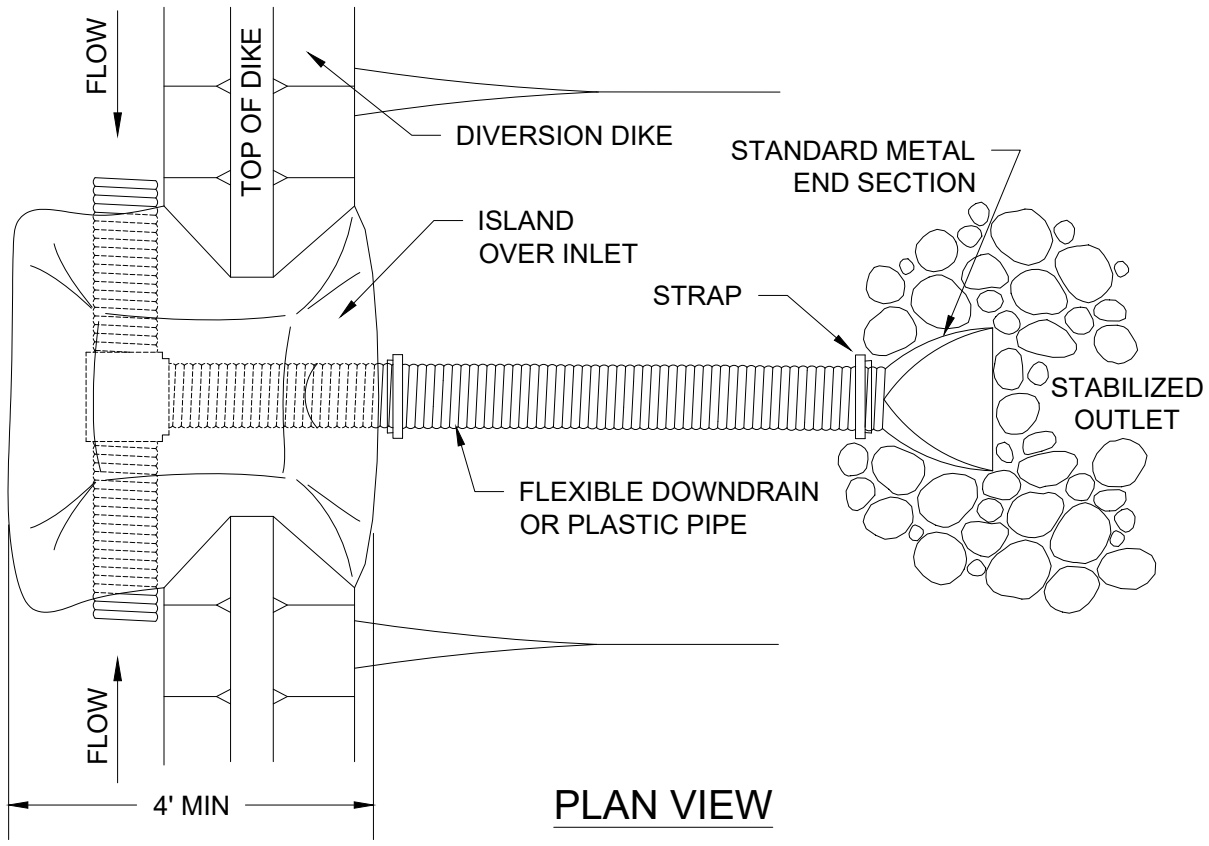

**NOTES:**

1. USE CABLE ANCHOR ON DOWNDRAIN FOR CRITICAL SLOPES OR SLOPES STEEPER THAN 1V:1.5H
2. FASTEN EXPOSED SECTIONS OF PIPE WITH GROMMETS OR STAKES SPACED 10' OR LESS
3. USE CABLE ANCHOR ON DOWNDRAIN FOR CRITICAL SLOPES OR SLOPES STEEPER THAN 1V:5H
4. EXTEND DRAIN BEYOND TOE OF SLOPE AND PROTECT OUTLET FROM EROSION (SEE EPSC-15)

**CITY OF GRESHAM**

**SLOPE DRAIN**

PUBLISHED: JULY 2026

DRAWN	KJR
REV. DATE	SEPT 2014
APPR.	
DETAIL NO.	EPSC-14

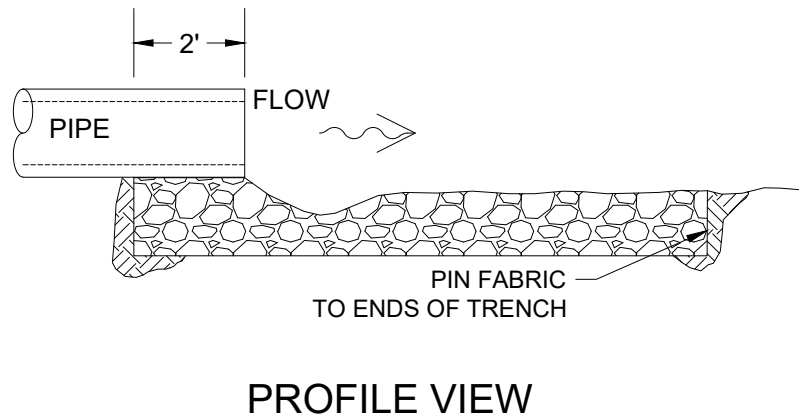
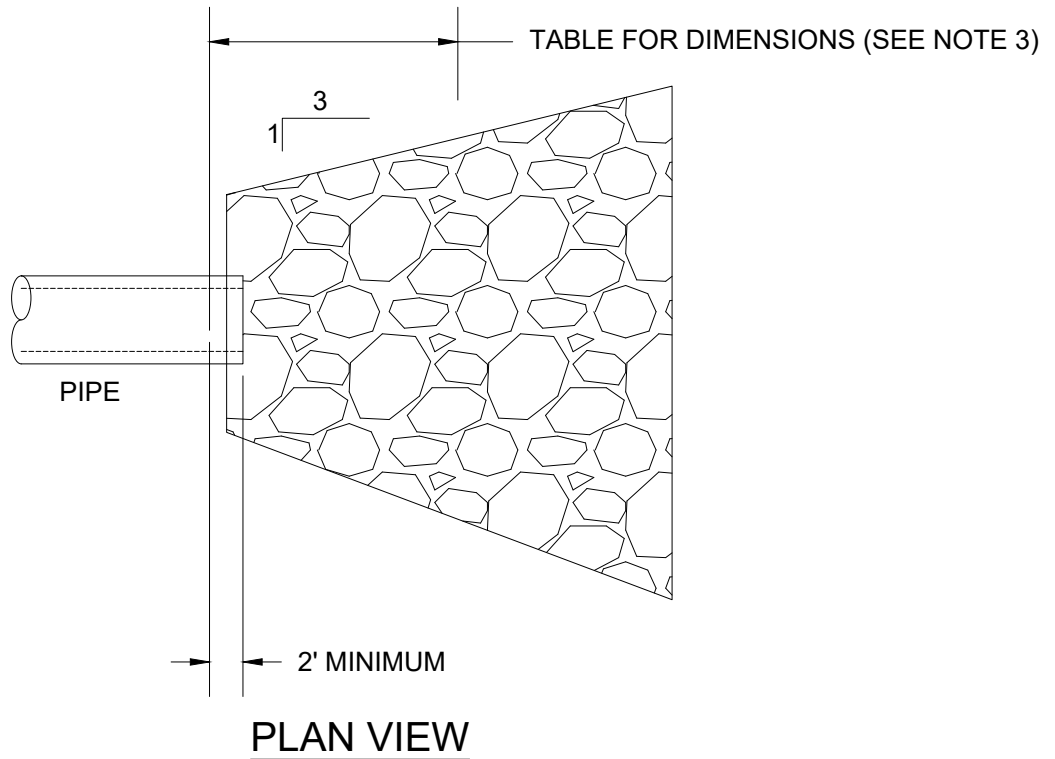

**NOTES:**

1. CONSTRUCT APRON SO FLAT; ZERO GRADE WITH NO OVERFLOW; FILTER FABRIC MUST BE USED; DO NOT TEAR AND OVERLAP JOINTS BY 1' MIN
2. RIPRAP IS FIELD STONE OR ROUGH QUARRY STONE
3. SEE ROCK PROTECTION AT OUTFALLS TABLE IN SECTION 4.05.04 OF PUBLIC WORKS STANDARDS

**CITY OF  
GRESHAM**

**ENERGY DISSIPATION/OUTLET PROTECTION**

PUBLISHED: JULY 2026

DRAWN KJR

REV. DATE SEPT 2014

APPR. 

DETAIL NO. EPSC-15

FILENAME: y:\inter-departmental\development\engineering\projects\public works standards\2.0 pws revision copy\details\cad -all\st and epsc details\epsc cad details\epsc-16.dwg, Plotted 6/22/2026 3:05 PM, By: Anthony Dollowitch, ANSI FULL BLEED A (8.50 X 11.00 INCHES)

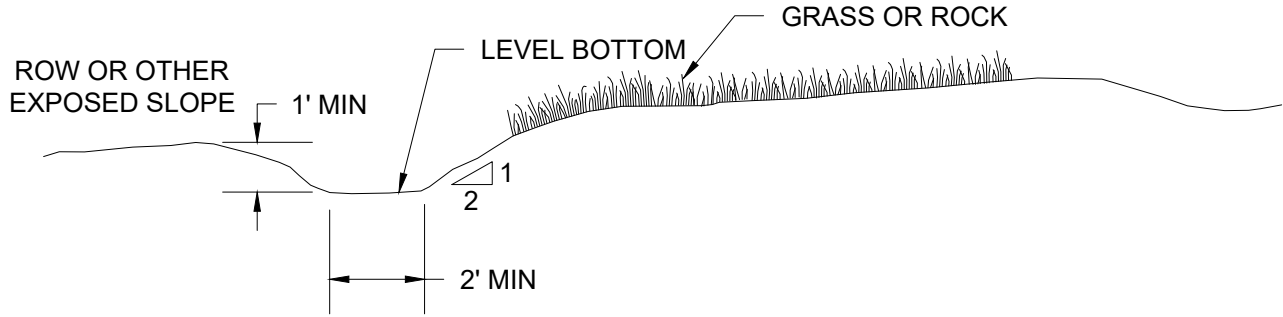

TOP/BOTTOM WIDTH	2 FEET MINIMUM; THE BOTTOM WIDTH SHALL BE LEVEL
HEIGHT/DEPTH	1 FOOT MINIMUM
SIDE SLOPE	2H:1V OR FLATTER
GRADE	MAXIMUM 5 PERCENT, WITH POSITIVE DRAINAGE TO A SUITABLE OUTLET SUCH AS TEMPORARY SEDIMENT BASIN (SEE EPSC-18)

**DIVERSION SWALE**

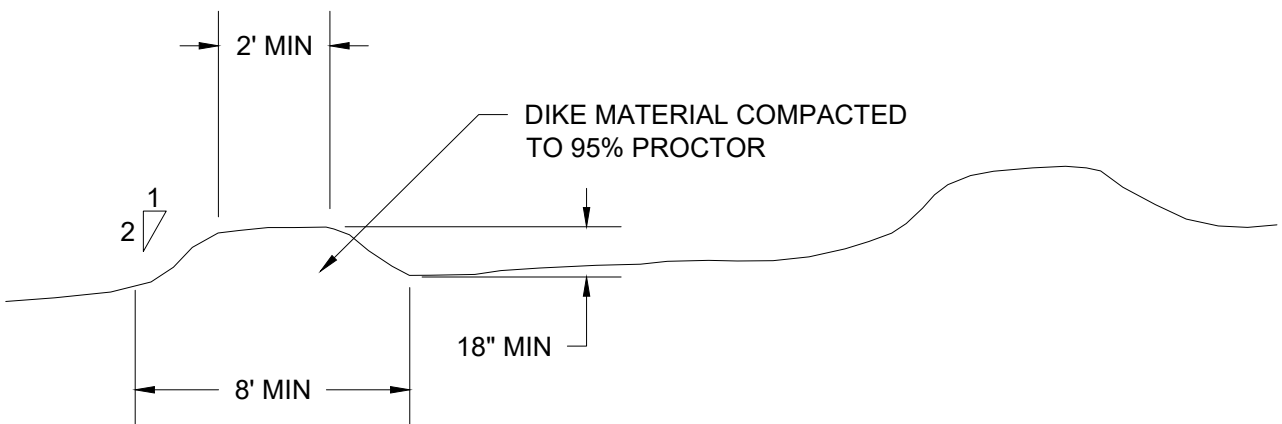

**TEMPORARY DIVERSION DIKE**

**NOTES:**

1. IMMEDIATELY UPON CONSTRUCTION, ESTABLISHED VEGETATION OR EROSION MATS (SEE EPSC-11) ARE REQUIRED
2. CHECK DAMS (SEE EPSC-17) MAY BE REQUIRED
3. ENERGY DISSIPATION (EPSC-15) MAY BE REQUIRED AT OUTLET



**DIVERSION DIKES/SWALES**

PUBLISHED: JULY 2026

DRAWN	KJR
REV. DATE	JUNE 2026
APPR.	
DETAIL NO.	EPSC-16

FILENAME: y:\inter-departmental\development\engineering projects\public works standards\2.0 pws revision copy\details\cad -all\st and epsc details\epsc cad details\epsc-17a.dwg, Plotted 6/22/2026 3:05 PM, By: Anthony Dollowitch, ANSI FULL BLEED A (8.50 X 11.00 INCHES)

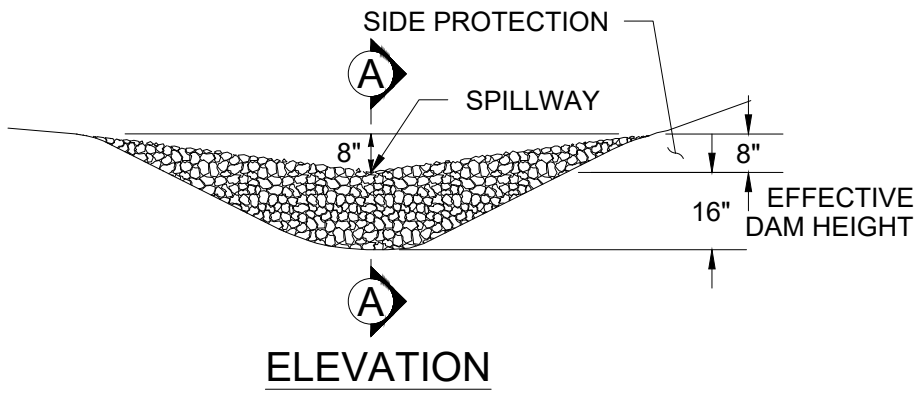

ELEVATION

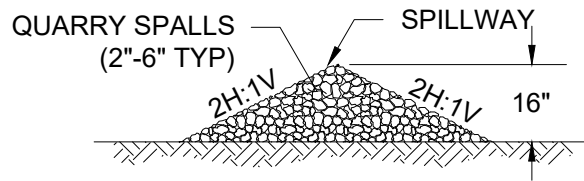

SECTION A-A

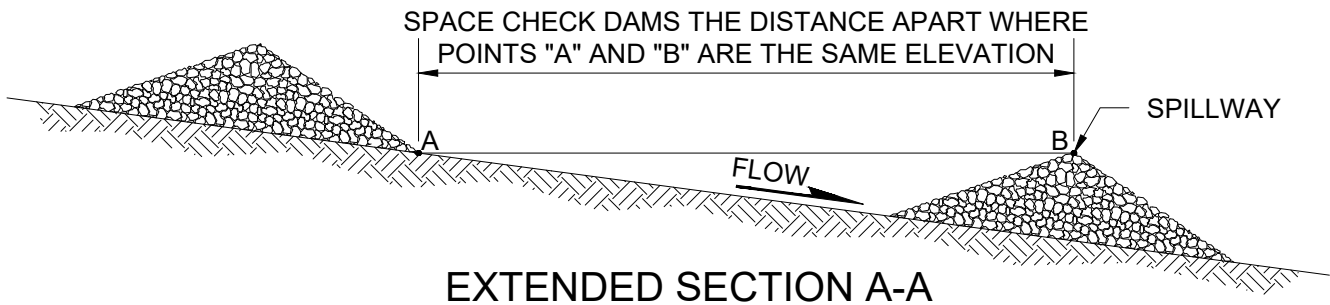

EXTENDED SECTION A-A

NOTES:

1. UPPER EXTENT MUST BE AT LEAST 6" ABOVE SPILLWAY
2. NOT FOR USE IN STREAMS OR RIVERS
3. CONSTRUCT WITH ROCKS TYPICALLY 2-6"

**CITY OF  
GRESHAM**

**ROCK CHECK DAM**

PUBLISHED: JULY 2026

DRAWN KJR

REV. DATE SEPT 2014

APPR. 

DETAIL NO. EPSC-17A

FILENAME: y:\inter-departmental\development\engineering\projects\public works standards\2.0 pws revision copy\details\cad -all\st and epsc details\epsc cad details\epsc-17b.dwg, Plotted 6/22/2026 3:05 PM, By: Anthony Dollowitch, ANSI FULL BLEED A (8.50 X 11.00 INCHES)

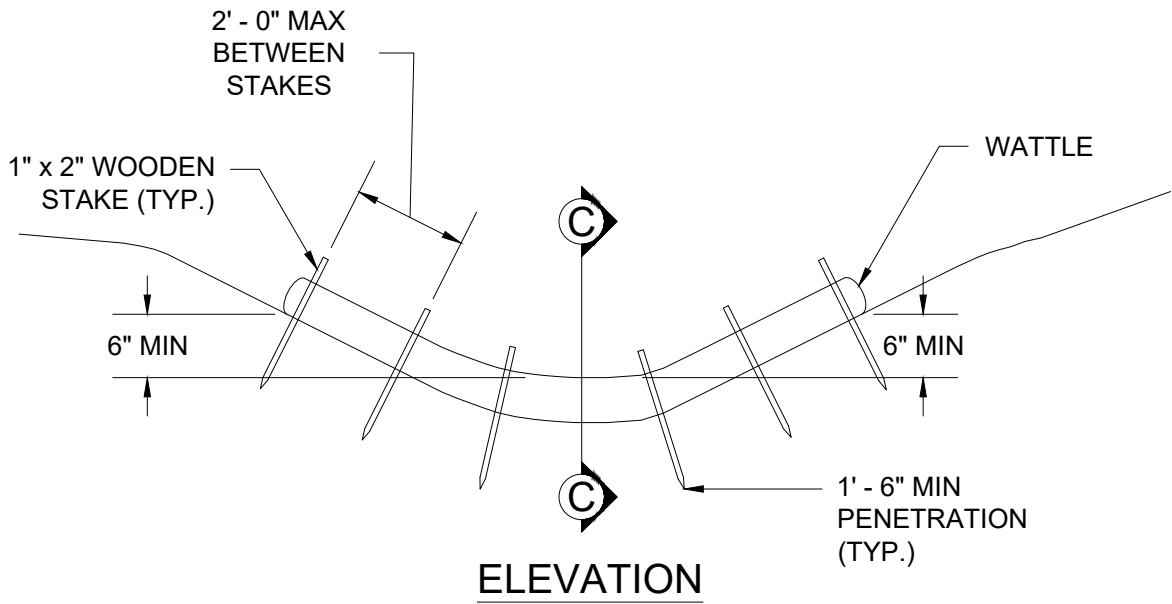

SPACE CHECK DAMS THE DISTANCE APART WHERE POINTS "A" AND "B" ARE THE SAME ELEVATION

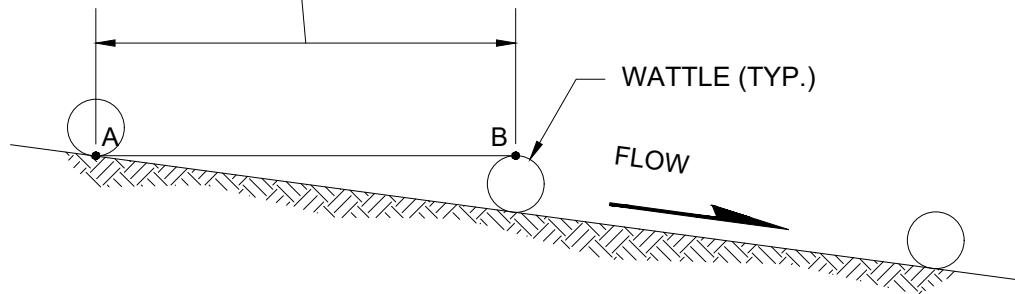

**NOTES:**

1. UPPER EXTENT MUST BE AT LEAST 6" ABOVE SPILLWAY
2. NOT FOR USE IN STREAMS OR RIVERS

**CITY OF GRESHAM**

**WATTLE CHECK DAM**

PUBLISHED: JULY 2026

DRAWN KJR

REV. DATE SEPT 2014

APPR. 

DETAIL NO. EPSC-17B

FILENAME: y:\inter-departmental\development\engineering\projects\public works standards\2.0 pws revision copy\details\cad -all\st and epsc details\epsc cad details\epsc-17c.dwg, Plotted 6/22/2026 3:05 PM, By: Anthony Dollowitch, ANSI FULL BLEED A (8.50 X 11.00 INCHES)

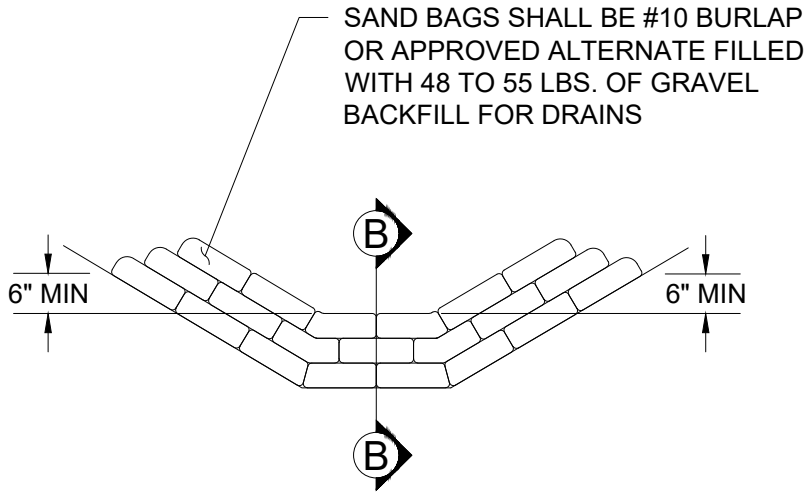

SAND BAGS SHALL BE #10 BURLAP OR APPROVED ALTERNATE FILLED WITH 48 TO 55 LBS. OF GRAVEL BACKFILL FOR DRAINS

ELEVATION

PLACE SAND BAGS FIRMLY AGAINST GROUND LINE AND ADJACENT SEND BAGS

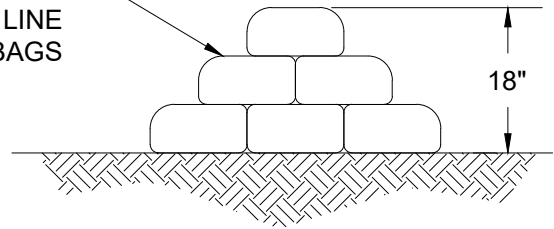

SECTION B-B

SPACE CHECK DAMS THE DISTANCE APART WHERE POINTS "A" AND "B" ARE THE SAME ELEVATION

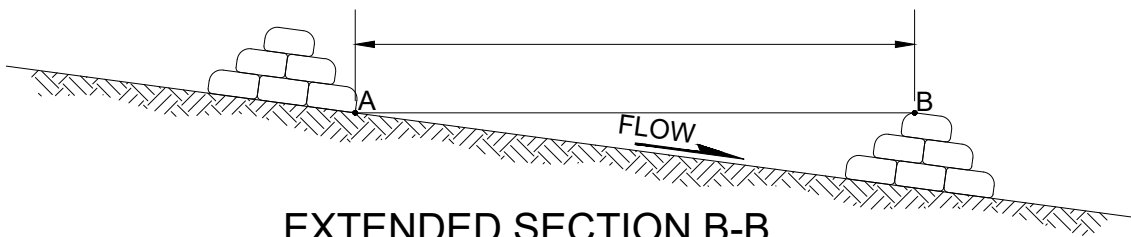

EXTENDED SECTION B-B

NOTES:

- 1. UPPER EXTENT MUST BE AT LEAST 6" ABOVE SPILLWAY
- 2. NOT FOR USE IN STREAMS OR RIVERS

**CITY OF GRESHAM**

**SAND BAG CHECK DAM**

PUBLISHED: JULY 2026

DRAWN KJR

REV. DATE SEPT 2014

APPR. 

DETAIL NO. EPSC-17C

FILENAME: y:\inter-departmental\development\engineering projects\public works standards\2.0 pws revision copy\details\cad -all\st and epsc details\epsc cad details\epsc-18.dwg, Plotted 6/22/2026 3:05 PM, By: Anthony Dollowitch, ANSI FULL BLEED A (8.50 X 11.00 INCHES)

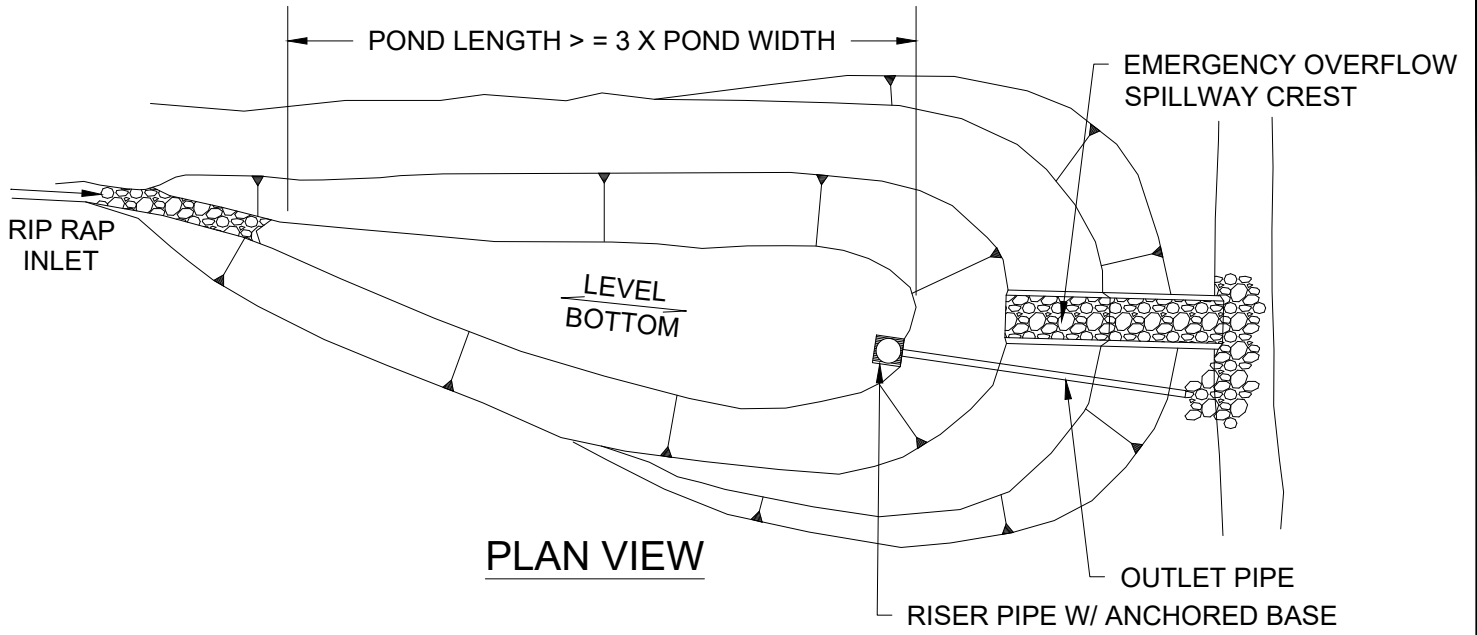

**PLAN VIEW**

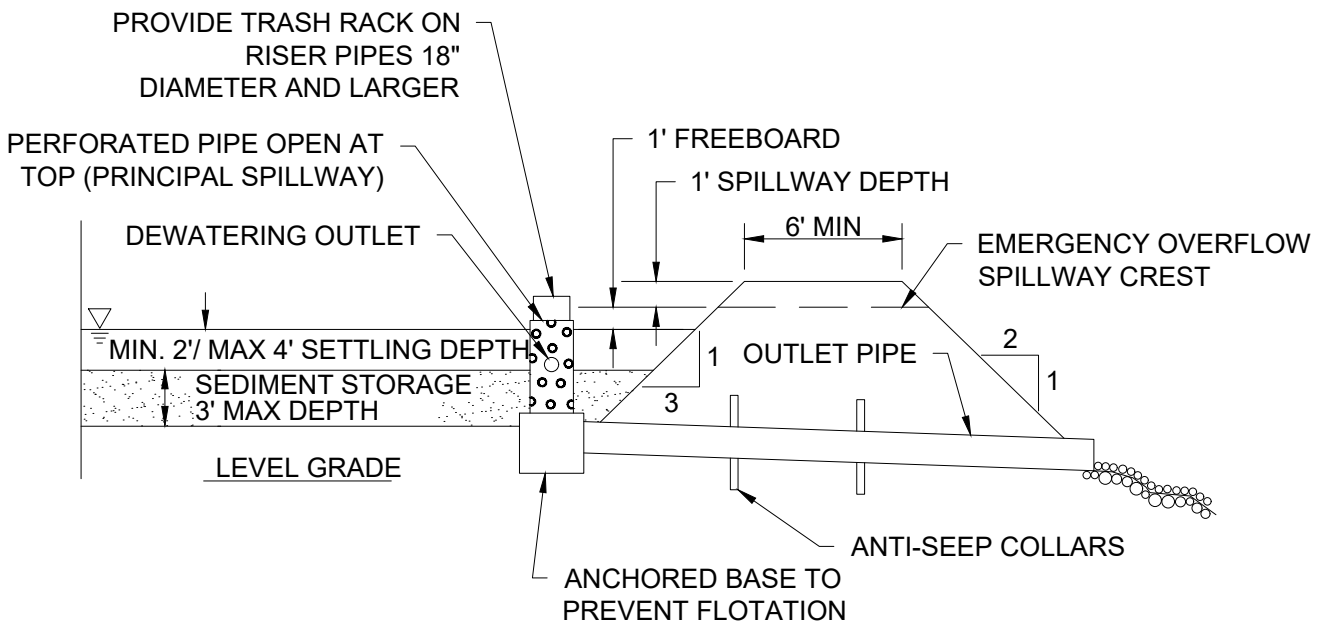

**PROFILE**

**NOTES:**

1. 50' MINIMUM OF HIGHLY VEGETATED AREA AND OR SEDIMENT FENCE IS REQUIRED PRIOR TO DISCHARGING TO STREAM OR WETLAND
2. MUST BE DESIGNED BY LICENSED ENGINEER
3. OUTLET SHALL BE SIZED TO EMPTY WITHIN 48 HOURS
4. BASINS SHALL BE SIZED TO RETAIN MIN OF 3,600 FT<sup>3</sup> PER ACRE OF DRAINAGE AREA

**CITY OF GRESHAM**

**TEMPORARY SEDIMENT BASIN**

PUBLISHED: JULY 2026

DRAWN	KJR
REV. DATE	SEPT 2014
APPR.	
DETAIL NO.	EPSC-18

FILENAME: y:\inter-departmental\development\engineering\projects\public works standards\2.0 pws revision copy\details\cad -all\st and epsc details\epsc cad details\epsc-20.dwg, Plotted 6/22/2026 3:05 PM, By: Anthony Dollowitch, ANSI FULL BLEED A (8.50 X 11.00 INCHES)

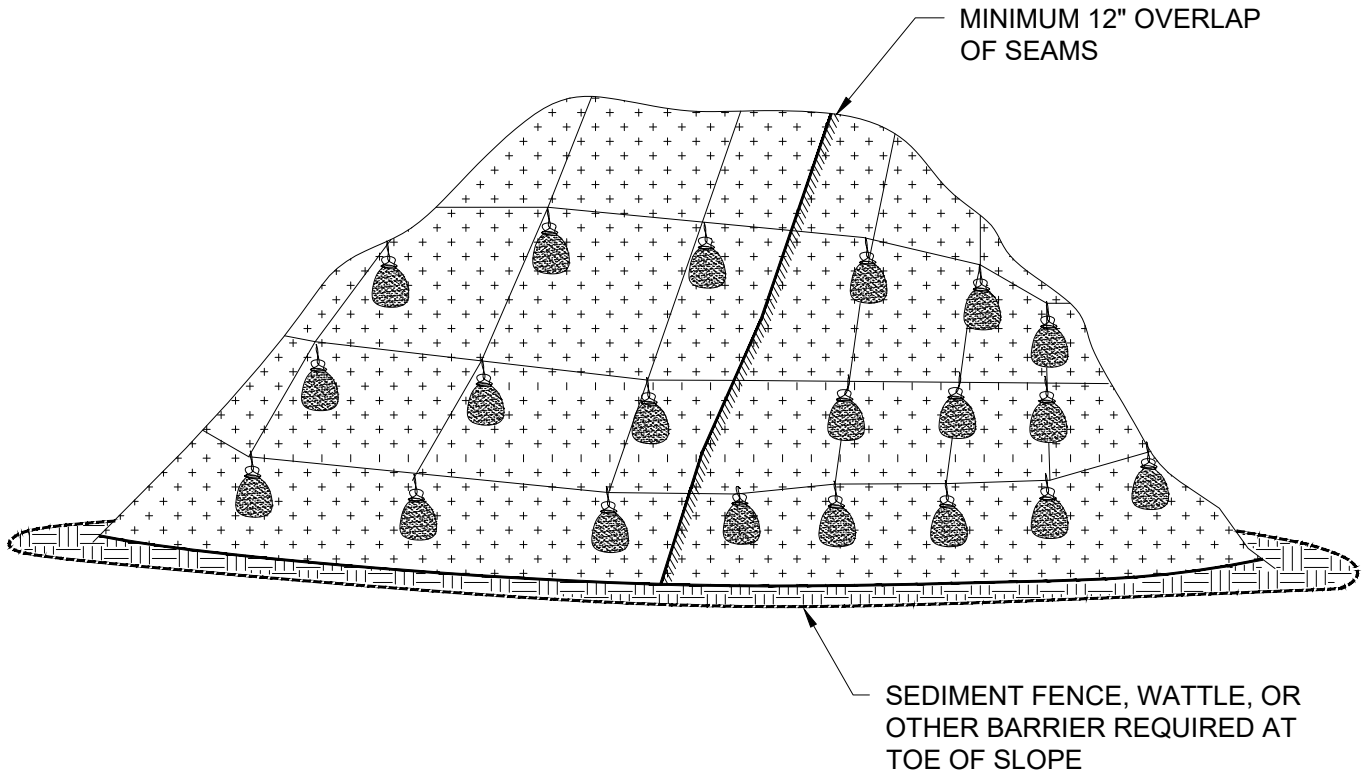

**NOTES:**

1. LOCATE MIN 50' FROM INLETS OR WATER BODIES
2. LIMIT STOCKPILE HEIGHT TO 15' UNLESS APPROVED BY CITY
3. STOCKPILES SHALL BE SEEDED WITH VEGETATION OR COVERED WITH PLASTIC OR MULCH PER EPSC-10
4. TEMPORARY SEEDING MUST BE APPLIED WITHIN 2 DAYS DURING WET SEASON (OCT 1-MAY 31) OR WITHIN 7 DAYS DURING DRY SEASON (JUNE 1-SEPT 3)
5. MINIMUM 12" OVERLAP OF ALL SEAMS REQUIRED
6. BARRIER REQUIRED AT TOE OF STOCK PILE
7. COVERING MAINTAINED TIGHTLY IN PLACE BY USING SANDBAGS OR TIRES ON ROPES WITH A MAXIMUM 10' GRID SPACING IN ALL DIRECTIONS
8. AVOID USING PLASTIC ON STOCKPILE LOCATED ABOVE STEEP OR UNSTABLE SLOPES

**CITY OF  
GRESHAM**

**SOIL STOCKPILE MANAGEMENT WITH PLASTIC SHEETING**

PUBLISHED: JULY 2026

DRAWN **KJR**

REV. DATE **SEPT 2014**

APPR. 

DETAIL NO. **EPSC-20**

FILENAME: y:\inter-departmental\development\engineering projects\public works standards\2.0 pws revision copy\details\cad -all\st and epsc details\epsc cad details\epsc-21.dwg, Plotted 6/22/2026 3:05 PM, By: Anthony Dollowitch, ANSI FULL BLEED A (8.50 X 11.00 INCHES)

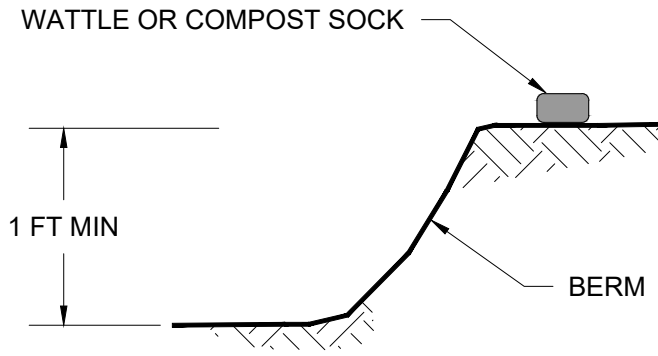

**SECTION A-A**

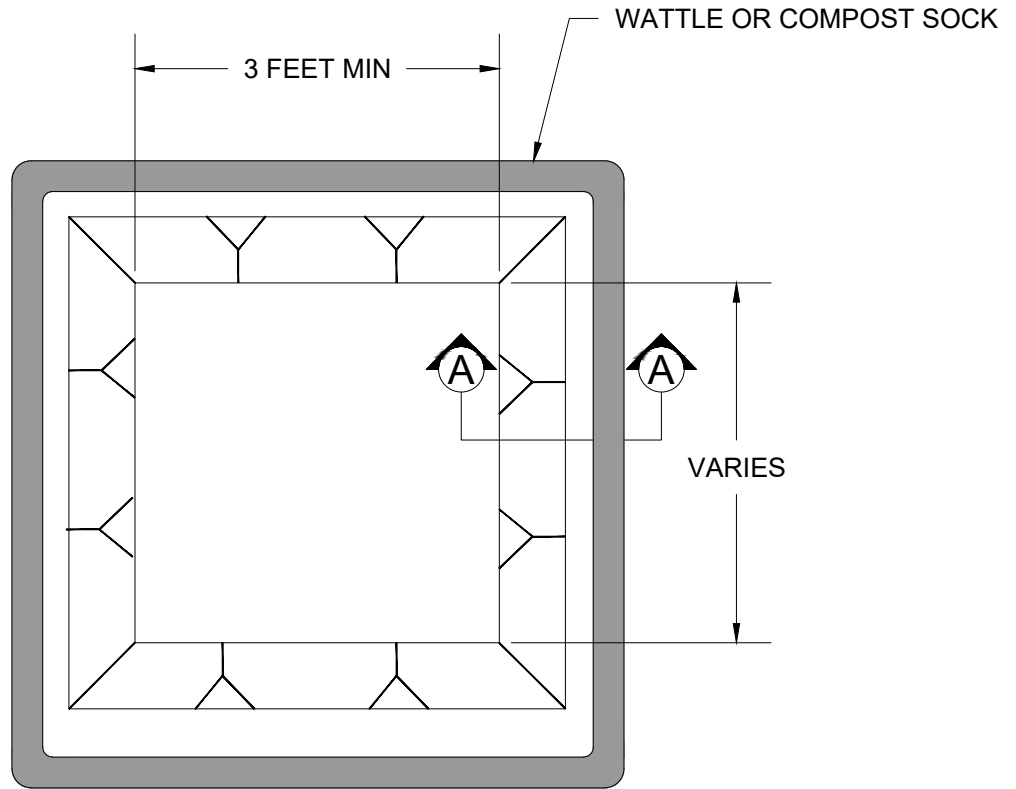

**PLAN**

**NOTES:**

1. ACTUAL LAYOUT DETERMINED IN THE FIELD
2. ALL CONCRETE TRUCKS WASHING OUT ON SITE SHALL USE CONCRETE WASHOUT
3. WASHOUT AREA SHALL BE LOCATED AWAY FROM STORM DRAINS AND WATER BODIES
4. EXCAVATED AREA SHALL BE LARGE ENOUGH TO PREVENT CONCRETE SLURRY OVERFLOW; SLURRY FROM CONCRETE CUTTING/CORING OR WORKING SHALL BE SHOVELED OR WET VACUUMED TO PREVENT FROM ENTERING STORM SYSTEM
5. WATTLE, COMPOST SOCK, SAND BAGS OR OTHER CONTAINMENT IS TO BE USED AROUND PERIMETER OF CLEANOUT

**CITY OF GRESHAM**

**CONCRETE MANAGEMENT**

PUBLISHED: JULY 2026

DRAWN	KJR
REV. DATE	SEPT 2014
APPR.	
DETAIL NO.	EPSC-21